



Regione Emilia-Romagna

ITACA HANDBOOK

Realizing Sustainable Mobility

Final Report
September 12, 2011



ITACA PROJECT

Innovative Transport Approach in Cities and metropolitan Areas

Coordination and Organizational Management of ITACA Project:

Paolo Ferrecchi, D.G. Infrastructural Networks, Logistics and Mobility Systems, Emilia-Romagna Region

Responsible for Development of ITACA Project:

Fabio Formentin, Head of Urban Mobility and Transport Local Department, Emilia-Romagna Region

Engineering and Designing of ITACA Project carried out by:

Luca Buzzoni, Urban Mobility and Transport Local Department, Emilia-Romagna Region

Website:

http://www.mobiliter.eu/wcm/mobiliter/pagine/approfondimenti/progetti_europei/itaca.htm

ITACA HANDBOOK

Realizing Sustainable Mobility

Authored and Assembled by:

Luca Buzzoni, Emilia-Romagna Region

Jason Meggs and *Joerg Schweizer*, University of Bologna

Coauthors:

Manuel B. Acevedo Pérez, Diputación Provincial De Huelva

Luca Buzzoni, Emilia-Romagna Region

Jeccika Eriksson, City of Lidingö

Fabio Formentin, Emilia-Romagna Region

Magda Kopczynska, EU Commission - Mobility and Transport DG

Eduardo López, Instituto Nacional de Técnica Aeroespacial (INTA)

Jason Meggs, University of Bologna

Helena Nybom, City of Lidingö

Alberto Rossini, Province di Rimini

Joerg Schweizer, University of Bologna

Michiel Visser, Stichting Brabantse Milieufederatie (BMF)

Monica Zanarini, Municipality of Ferrara

TABLE OF CONTENTS

Foreword.....	5
Project background.....	7
Chapter 1: Introduction.....	11
1.1 The ITACA project and its goals.....	13
1.1.1 How to reduce trip generation?.....	14
1.1.2 How to ensure people choose close destinations.....	15
1.1.3 How to choose and provide environmentally friendly modes?.....	15
1.1.4 How to optimize route choice?.....	16
1.2 Demand Management Models.....	17
1.3 The Need for New Propulsion Technologies.....	18
1.4 Launchpad to ITACA.....	20
Chapter 2: Demand Management Models.....	21
2.1 How manageable is transport demand?.....	22
2.1.1 Theoretical modeling frameworks.....	23
2.1.1.1 <i>Utility maximization models</i>	23
2.1.1.2 <i>Models and findings from transport psychology</i>	25
2.1.2 The potential of direct behavioural change.....	27
2.1.2.1 <i>Incentive schemes versus disincentive schemes</i>	28
2.1.2.2 <i>Incentive schemes</i>	29
2.1.2.3 <i>Disincentive schemes</i>	30
2.1.3 Potential of land-use and planning policies.....	33
2.1.3.1 <i>High urban density and corridors</i>	34
2.1.3.2 <i>Mixed land use</i>	35
2.1.3.3 <i>Accessibility for soft modes</i>	36
2.1.4 Transport Supply/Demand Management.....	40
2.2 Showcases / best practices - Direct behavioural change.....	40
2.2.1 Emilia-Romagna Regional Mobility Plan.....	40
2.2.2 Environmental Management and Sustainable Mobility of Health Care Companies in Emilia-Romagna.....	42
2.2.3 Pedibus: providing a structured opportunity for elementary and middle-school students to walk to school together, in Emilia-Romagna.....	43
2.2.4 Congestion Tax in Stockholm: changing behaviour through pricing, by introducing a higher charge for entering a congested area during peak times.....	45
2.2.5 Avoiding rush hour (spitsmijden).....	48
2.2.6 Semi-pedestrian zone at Bologna's University quarter.....	51
2.2.7 Towards the new Regional Integrated Transport Plan, Emilia-Romagna.....	53
2.3 Showcases / best practice - Land Use Planning Policies.....	54
2.3.1 Mobility management in APEA: placing a Canteen in an industrial area.....	54
2.3.2 Comprehensive and Environmental Plans, Lidingö, Sweden.....	55
2.4 Showcases / best practice - Transportation Supply/Demand Management.....	59
2.4.1 Green Parking Initiative (GPI).....	59
2.4.2 Sustainable Urban Mobility Plan for the Province of Huelva.....	61
2.4.3 Bicycle paths in the Province of Rimini.....	63
2.4.4 Bike Sharing.....	63
2.4.4.1 <i>Bike Sharing in Emilia-Romania: "C'entro in Bici" and "Mi muovo in Bici"</i>	64

2.4.4.2 Public Transport Bike (OV Fiets)	65
2.4.5 CONCABUS (or “Valcona”):.....	65
2.4.6 Mobility management in APEA: sustainable transport supply management at an Italian industrial site	66
2.4.7 Monitoring of Regional Car-Sharing, Emilia-Romagna Region.....	67
2.4.8 Home-to-work Travel Plan (PSCL) for Hospital Campuses in Decentralised Areas of a Province; Ferrara, Emilia-Romagna Region.....	68
2.5 Conclusions and Recommendations	69
2.5.1 Direct behaviour change.....	71
2.5.2 Supply and Demand Management	72
2.5.3 Land Use	73
2.6 Literature.....	74
Chapter 3: Innovative Technologies	77
3.1 ITACA Innovative Technologies: Inventory and State of the Art.....	77
3.1.1 The City as Technology.....	77
3.1.2 New Vehicle Propulsion Systems	78
3.2 Real Operation Vehicle Database Analysis and Results	88
3.2.1 Configuration of database.....	88
3.2.2 Project and city	96
3.2.3 Climatology and physical characteristics	101
3.2.4 Technology.....	103
3.2.5 Fuel and costs.....	108
3.2.6 Emissions	114
3.2.7 Energy consumption	127
3.2.8 Conclusions	131
3.2.9 Recommendations.....	133
3.3 Showcases and Good Practices	134
3.3.1 New propulsion systems.....	134
3.3.2 Low-carbon fuels and renewable energies in the urban transport.....	139
3.3.2.1 Use of low-carbon fuels in methane and internal combustion engine buses:.....	140
3.3.2.2 HCNG: Combining hydrogen with natural gas.....	143
3.3.2.3 Use of “green” electricity to power electric vehicles.....	148
3.3.2.4 Use of hydrogen produced from renewable energy in fuel cell vehicles.....	149
3.3.3 Intelligent Transport Systems (ITS) / Information and Communication Technologies (ICT) for CO2 reduction	152
3.3.3.1 Use of ITS to avoid congestion and “rush” hours.	153
3.3.3.2. Sustainable Traffic Management: maximizing use of existing system	153
3.3.3.3. Inter-modal transportation systems: fare and ticketing integration systems	154
3.4 Conclusions and Recommendations: Innovative Technologies	155
3.4.1 Propulsion systems and fuel types	156
3.4.2 Outlook	158
3.5 References and Additional Information	164
3.5.1 State of the art references.....	164
3.5.2 Showcases and good practices additional information	165

Chapter 4: ITACA Conclusions	167
Annex I: Demand Management Models	171
I.1 Behaviour.....	172
I.2 Land Use Planning Policies	182
I.3 Transport Supply/Demand Management	193
ANNEX II: Innovative Technologies	239
ANNEX III: Alternative Vehicle Propulsion Technologies & ITS	267
III.1 Alternative Propulsion Systems	267
III.1.1 Pure batteries electric vehicle (BEV)	267
III.1.2 Batteries Parameters	270
III.1.3 Type of battery	272
III.1.4 Hybrid Electric vehicle (HEV).....	274
III.1.5 Fuel Cell Electric vehicle.....	281
III.1.6 Internal combustion engine with biogas, natural gas and mixtures with hydrogen.....	283
III.1.6.1 Several ways of producing biogas [17]:	283
III.1.6.2 Types of biogas production:	284
III.1.6.3 Use of biogas in vehicles [18].	286
III.1.6.4 Hydrogen mixtures with natural gas.....	287
III.2 Intelligent transportation systems (ITS).....	289
III.2.1 Intelligent infrastructure:.....	290
III.2.2 Intelligent vehicle systems:	292

June 2011

Foreword

A large majority of European citizens live in an urban environment, with over 60% living in built-up areas of over 10,000 inhabitants. Congestion, poor air quality and noise exposure principally affect urban areas. Urban mobility accounts for about a quarter of CO₂ emissions from transport, and almost 70% of road accidents take place in cities.

The question of how to enhance mobility, while at the same time reducing congestion, accidents and pollution, remains a common challenge for all major cities in Europe. I trust that some solutions are forthcoming through the adoption on 28 March 2011 of the **White Paper: Roadmap to a Single European Transport Area – Towards a competitive and resource efficient transport system**.

The ITACA project's aim of contributing to the reduction of CO₂ emissions related to urban transport is fully in line with the recent White Paper, and the examples of best practice that it offers are extremely welcome as a useful resource for policy-makers.

Besides the target of a 60% reduction in CO₂ emissions from transport by 2050, the new White Paper calls for halving the use of conventional - diesel and gasoline - cars by 2030, and for phasing them out by 2050. This is a very tough challenge bearing in mind that transport today relies almost entirely on oil, and that peak oil production is forecast in the next decade. The combustion of oil from vehicles is one of the main causes for CO₂ emissions and climate change; and emissions from transport are on the increase – which is clearly an unsustainable situation.

Looking back at the overall political framework, the Commission presented in March 2010 its **'Europe 2020'** Strategy for smart, sustainable and inclusive growth in Europe. This strategy paper stresses the importance of a modernised transport system for the future development of the EU and outlines three very important and mutually reinforcing priorities:

Smart growth, developing an economy based on knowledge and innovation;
Sustainable growth, promoting a more resource efficient, greener and more competitive economy;
Inclusive growth, fostering a high-employment economy delivering social and territorial cohesion.

Therefore, we need to develop a range of measures to allow us to reach a near-zero carbon transport system by 2050. These measures must take into consideration all aspects of technology, infrastructure, regulatory issues and incentives. We will look more closely at how the upcoming research framework programme – HORIZON 2020 – as well as specific policy measures can help us achieve our ambitious targets of making European transport more sustainable, better adapted to societal challenges, and also more competitive.

We also need the political will to strengthen support for the necessary research and technological development, to help achieve market readiness and to secure a leading place for Europe with regard to global competition. And finally, we must remember that our personal mobility choices directly impact on how clean and green our cities remain!



Magda Kopczynska

Project background

ITACA is a POWER INTERREG IV C Programme subproject which aims to reduce carbon emissions in metropolitan areas by identification, assessment and exchange of innovative technologies and management plans for public and private transport. This entails the development of public sector strategies for optimising the design and delivery of sustainable transport solutions, comprising several approaches like the identification of innovative and eco-friendly technologies suitable to be used in urban areas both in public and private transport, realistic assessment of impacts, benefits, costs and requirements for infrastructure and supply chains, barriers and gaps, R&D and Innovation priorities, etc.

ITACA partners are:

- Regione Emilia-Romagna (Emilia-Romagna, Italy)
- Instituto Nacional de Técnica Aeroespacial (INTA) (Andalucía, Spain)
- Provincia di Rimini (Emilia-Romagna, Italy)
- Comune di Ferrara (Emilia-Romagna, Italy)
- Stichting Brabantse Milieufederatie (Noord-Brabant, The Netherlands)
- Diputación Provincial de Huelva (Andalucía, Spain)
- City of Lidingö (Stockholm Region, Sweden)

ITACA sister project: TraCit (Transport Carbon IntenCities),
<http://www.tracit.org.uk/>

About POWER and INTERREG IV C:

POWER is a €5.8m inter-regional programme aimed at driving Low Carbon Economies partly funded through INTERREG IVC in seven European regions:

- Andalucía (Spain)
- Emilia-Romagna (Italy)
- Malopolska (Poland)
- Noord-Brabant (The Netherlands)
- South East England (England)
- Stockholm (Sweden)
- Tallinn (Estonia)

The INTERREG IVC Programme is part of the European Territorial Cooperation objective of the Structural Fund policies for the period 2007-2013. It aims, by means of interregional cooperation, to improve the effectiveness of regional development policies and contribute to economic modernisation and increased competitiveness of Europe, by:

- Enabling local and regional actors across the EU to exchange their experiences and knowledge;
- Matching regions less experienced in a certain policy field with more advanced regions;
- Ensuring the transfer of good practices into Structural Funds mainstream programmes.

Nine projects are funded under POWER in the following areas of joint co-operation:

- Energy Efficiency
- Renewable Energies
- Eco-innovation and environmental technologies
- Sustainable transport
- Behaviour Change

Results from the projects will inform the network of regional policy experts in their field and be used to ensure a more integrated policy framework with a greater awareness and ownership at ground level.

More information about POWER PROGRAMME and INTERREG IV C:

<http://www.powerprogramme.eu/index.php>

www.interreg4c.eu

http://ec.europa.eu/regional_policy/index_en.htm

ITACA contacts and information:

Lead Partner:

Regione Emilia-Romagna – Emilia-Romagna Region

Luca Buzzoni

Tel: ++ 39 051 5273441

Email: lbuzzoni@regione.emilia-romagna.it

Partnership:

Instituto Nacional de Técnica Aeroespacial (INTA)

Eduardo López

Tel: ++ 34 959 208848

Email: lopezge@inta.es

Website : <http://www.inta.es/NoticiaActualidad.aspx?Id=2114>

Provincia di Rimini - Province of Rimini

Alberto Rossini

Tel: ++39 0541 716224

Email: A.Rossini@provincia.rimini.it

Website www.provincia.rimini.it

Comune di Ferrara - Municipality of Ferrara

Monica Zanarini

Tel: ++39 0532 418838

Email: m.zanarini@comune.fe.it

Website www.ferrara.comune.fe.it

Stichting Brabantse Milieufederatie 14
Michiel Visser
Tel: ++ +31 (0)13 5356 225
Email: michiel.visser@brabantsemilieufederatie.nl
Website http://www.brabantsemilieufederatie.nl/POWER_ITACA

Diputación Provincial de Huelva
Manuel B. Acevedo Pérez,
Tel: ++ 34 959494649
Email: macevedo@diphuelva.org
Website www.diphuelva.org

City of Lidingö
Helena Nybom
Tel: ++46 70 6376099
Email: helena.nybom@lidingo.se
Website www.lidingo.se

Technical Assistance:

University of Bologna
Jason N. Meggs and Joerg Schweizer
DICAM-Transport Engineering Group
Viale Risorgimento, 2
40136 Bologna, Italy
Tel: +39 051 209 3338
Fax: +39 051 209 3337
E-mail: jason.meggs@unibo.it
E-mail: joerg.schweizer@unibo.it
Website: <http://www.eng.dicam.unibo.it/>

ITACA Webpage: <http://www.powerprogramme.eu/projects.php?project=ITACA>

Chapter 1: Introduction

Balancing mobility with its costs and harms has become a paramount challenge of this century. The EU Green Paper (2007) brings it to a point: “The challenge facing urban areas in the context of sustainable development is immense: that of reconciling the economic development of towns and cities and accessibility with growth, the quality of life and with environmental protection, on the other.”

“Old challenges remain but new have come”, declares the EU White Paper Transport 2050 *Roadmap to a Single European Transport Area – Towards a competitive and resource efficient transport system*. The following are cited as “new challenges”:

- The transport systems of the eastern and western parts of Europe must be united to fully reflect the transport needs of almost the whole continent and our 500 million citizens.
- Oil will become scarcer in future decades, sourced increasingly from uncertain supplies. As the IEA has recently pointed out, the less successful the world is in decarbonising, the greater will be the oil price increase. In 2010, the oil import bill was around € 210 billion for the EU
- The EU needs to reduce carbon emissions by 80-95% below 1990 levels by 2050 (and 60% reduction in CO₂ emissions from transport), in the context of the necessary reductions of the developed countries as a group, in order to reach this goal.

In the EU, transport depends on oil and oil products for more than 96% of its energy needs. Europe imports around 84% of its crude oil from abroad.

Despite the efforts to increase transport efficiency, transport greenhouse gas emissions, including those from international aviation and maritime transport, increased by around 34% between 1990 and 2008 (see Figure 1.1).

Evolution of GDP, population, GHG emissions from transport, freight and passenger transport since 1995 (EU-27; 1995=100)

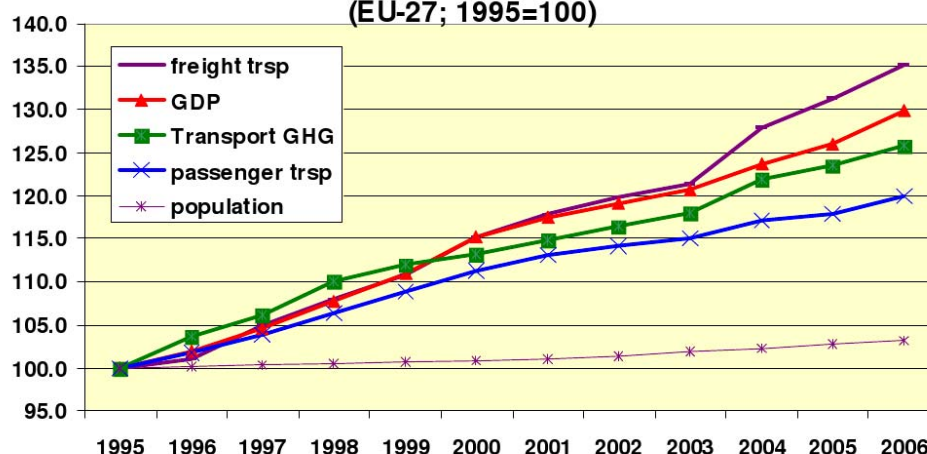

Figure 1.1: Source EEA

For comparison, over the same period, energy industries reduced their emissions by about 9%. Transport is responsible for about a quarter of the EU's greenhouse gas emissions. 71.3% of overall emissions are generated by road transport (2008).

One major reason for the failure to curb transport emissions and related negative effects is that transport demand increase is stronger than transport energy efficiency improvements. Most transport improvements were actually targeted at increasing existing transport capacities, removing bottlenecks as well as increasing transport speed which in turn generated new demand.

So far, EU policy has been very successful in developing and improving the supply side of transport: in particular, infrastructure, transport systems and logistics. But if the transport CO₂ emission reduction of 60% reduction is to be met by 2050 then it is inevitable to work on both sides: making transport *supply more energy-efficient* while *decreasing transport demand*, thus making the entire system more energy efficient and thus closer to carbon-neutral.

That latter point is not undisputed, as there is an association between economic growth and the growth in transport activity. However, at least in the case of person transport, it is not obvious that a higher number of passenger km is required to sustain economic growth: while a person is driving a car, he/she neither produces goods and services, nor does she/he buy or consume, except for petrol. Further, driving in urban environments is stressful. Employees arriving stressed at their work places have a lower productivity

In Economic terms, transport is well known as a *derived demand*, meaning that people travel for a certain purpose, such as work, study, shopping or recreation, but it is *unusual to travel solely for the purpose of traveling*.

If transport is not the primary goal but is responsible for many negative impacts, then travelling should be minimized where possible, and further, wherever

traveling takes place, its impacts should be minimized. Identifying opportunities for improvements and evaluating best practice applications that respect the socio-economic diversity of European regions is at the heart of the ITACA project.

One of the most prominent examples from ITACA partner countries Spain and Sweden should be cited here: Spain is Europe's most sun-rich country, while Sweden has its highest Biomass resources. For Sweden bio-fuels is the preferred way to de-carbonized transport while Spain would produce electricity from concentrated solar power or photovoltaic plants.

Section 1.1 describes the overall goals of the project and shows in a systematic scheme how the ITACA project does contribute to increase energy efficiency and to reduce carbon emissions in transport.

ITACA's activities are split in two types of projects *Transport demand management* and *Transport technologies*. Section 1.2 introduces the concept and need for Transport Demand Management models while section 1.3 explains the need for new propulsion technologies and highlights European initiatives and regulations in this field.

1.1 The ITACA project and its goals

ITACA aims at lowering carbon output of urban transport through the use of innovative sustainable technologies coupled with demand management. The ITACA goal is to identify, assess and share effective methods. ITACA hopes to thus foster public sector strategies for optimising the effectiveness of sustainable transport solution adoption. This broad goal is comprised of numerous approaches.

As cited above, there has been a strong European focus on improving the supply side of transport which has shown negative effects over the past decade. Despite the great potentials of future propulsion technologies, it needs to be recognized that transport is more than efficiency, capacity and speed. Transport is a part of everyone's daily experience, and people organize their lives around the transport options being offered. The interaction between supply and demand results in the overall usage of transport systems. The focus of the EU on developing new transport technologies is justified as to increase Europe's industrial competitiveness, a strategic sector. On the other hand, in terms of CO₂ reduction, it may turn out to be equally important to export European low carbon lifestyles, especially to those countries who cannot afford the latest technologies but are in an urgent need for solutions for their fast growing economies and populations.

This is why ITACA is examining the whole spectrum of options, which include both, the transport supply side as well as transport demand side.

In this sense, the 4-stage demand model, as used in classic transport planning, offers an appropriate scientific framework under which the different ITACA best practices and showcases can be classified. The 4-stage demand model is based on the hypothesis that a trip made by an individual generally starts with a series of decisions:

1. *Trip generation*: For which purpose do I travel?
2. *Trip distribution*: Which destination do I choose for my purpose?
3. *Modal choice*: Which transport mode do I choose to get to the destination?
4. *Route choice*: Which route do I take to get to my destination with the chosen mode?

These 4 decisions are made at some stage before the trip starts, although not always in this precise order. In any case, these decisions should be of paramount importance when it comes to encouraging decision-making in favor of the most sustainable options. For this reason, the 4-step decision tree is used as a guideline to identify transport impact reduction potentials in a systematic way. We thus discuss these each in turn, below, and these concepts will be further developed and exemplified in subsequent chapters.

1.1.1 How to reduce trip generation?

The avoidance of trip generation is very effective, as a trip that does not take place has zero impact and requires zero resources. In order to reduce trip generation these questions need to be addressed: For which activities do we actually need to leave home or workplace? Are there possibilities to work and study, or to do recreation at home? To attend meetings without leaving the office? Is it more effective to go out for shopping or to order the items via Internet, so the goods will be delivered instead? What measures can be taken on the government side to avoid trip generation? Internet access and the knowledge on how to use it should thus be a top priority, given the advanced opportunities for remote collaboration that now exist.

There are many other ways to increase home-based autonomy of citizens, such as the use of water catchment; gardening in yards, windows, and balconies; improving home delivery services; etc. Avoidance of trip generation also has a social benefit, in particular for elderly people and those with disabilities, who may have problems traveling. Time not spent traveling has potential to be invested in more useful ways, from social involvement to economic productivity. There has been a series of activities and improvements over time, yet systematic trip generation avoidance has not been the focus of EU research, despite its potential. ITACA has studied a scheme where citizens are incentivized not to make a trip, at least not during peak hours (See Demand Management Models, Chapter 2, Section 2.2, Behavioural Changes).

1.1.2 How to ensure people choose close destinations

The citizen will choose the destination which is most opportune for his/her trip purpose. The choice of the destination does of course depend on their vicinity to the origin, but also on the availability of transport modes at that origin. In order to shorten trip distances, the destination should be close to the origin and accessible. Reducing trip distances by moving potential destinations closer to residential origins has two major effects:

- (i) The negative impacts (energy use, emissions and congestions, accidents) decrease proportionally with a decreasing trip distance.
- (ii) Short distances favor walking and cycling, the most accessible, affordable and environmental friendly mode choices. Destinations should thus be accessible by bike and by foot. Remote destinations should in turn be accessible by efficient public transport, though this is often a major challenge as collective transport has problems to cover wider areas.

Minimizing distances is very much a land use issue. Transit-oriented development, mixed land use, densification of centers near transit hubs, prioritizing a balanced mix of services, and corridor-oriented development are key strategies for addressing land use. Developing or transforming urban areas is generally regarded as a long term plan, still the effectiveness can be significant, arguably essential. Even smaller and short-term changes in land-use can produce excellent results as shown in an ITACA showcase (See Demand Management Models, Chapter 2, Section 2.3, Land Use Planning Policies). Simply focusing the options for commercial use permit in order to foster more local access to goods and services, particularly essentials and high demand destinations, can rather quickly have a positive effect on destination choice and thus reduce trip distances.

1.1.3 How to choose and provide environmentally friendly modes?

Mode choice has two concrete potentials for reducing transport impact:

1. Behavioural change of citizens in favor of more sustainable transport modes, such as walking and cycling for short distance and public transport or car-sharing for longer distances. Behavioural changes may appear difficult and slow to realize, but once they are accomplished, they will have an immediate and potentially long-lasting effect – if the alternative sustainable modes are made available (for example footpath, safe cycle-way, or quality public transport). True behavioural changes can be achieved if the citizen can see an immediate advantage of the new choice (For further details, see Demand Management Models, Chapter 2, Section 2.2, Behavioural Changes). Information and communication technologies have the potential to increase the attractiveness of public transport and thus convince more people to use public transport instead of the private car: Passenger information systems can help users to navigate through complex networks which is a great help in particular for new commuters (see

2. Reduction of negative impacts of existing modes. This is the main subject of new propulsion and fuel technologies such as electric, gas or Hydrogen (see Chapter 3, Innovative Technologies). Technological innovations have a great potential to reduce emissions. But they need to become affordable, more supported, and in many cases, more effective through further research and development. Electric cars could contribute to savings of 5 Mt CO₂/year if the national and regional objectives of putting 5 million electric vehicles on the market by 2020 are met. However, fossil fuels combine low costs and high energy densities and it will be difficult to find a cost-efficient one-to-one replacement for internal combustion engines. As for example, today's electric car would need a battery pack weighing 2 500 kilos to provide the same energy as a diesel car with a 50-litre tank.

It will further take years for a new propulsion technology and new infrastructure to substitute the present motors and gasoline stations. However, an increasing oil price will accelerate both development of alternatives as well as their market penetration. There is already a rapid development of new battery types with performances and costs that surpass expectations year by year. When evaluating new technologies it is very important to assess their speed of development and the duration of their introduction phase. This has been done in great detail in Chapter 2, Innovative Technologies, Electric and Fuel Cell Vehicles, and its accompanying background section, Annex III. Linked to the propulsion technology is the question of energy production because only if electricity and hydrogen is produced from renewable sources there is a significant net benefit in CO₂ emission reduction. More details in the Technology chapter, Renewable Energies section.

In some cases the above approaches are not clearly separable, as new technologies do also require a change of habits. For example small, light-weight electric cars, sometimes called micro-cars, are already becoming competitive. Their low weight, limited range and limited speed do dramatically reduce battery weight and costs (100-200kg of batteries is sufficient for a micro-car). Their speed and range are appropriate for an average urban trip. However, micro-cars would require some changes of habits, and acceptance of the new limits; for example, adjusting to charge the car at night, and to be more flexible about choosing destinations spontaneously. Electric Car-sharing is another example where behavioural changes and technological innovation gain from synchronous introduction.

1.1.4 How to optimize route choice?

Most traffic participants, independent of transport mode (car, bike, public transport or walking), would choose the quickest route from origin to destination (although occasionally fare costs or comfort may play a role in choosing the best route). A common problem is that the traveler is not always informed about the quickest way through a transport network. The potential for revolutionary new information and communication technologies to provide traffic participants

with dynamic travel option information is tremendous, thus allowing individuals to know and choose not only their best possible route, but even their mode. There is no reason why such a service couldn't also communicate the most sustainable methods of travel; overcoming lack of awareness of more sustainable travel options is one of the biggest barriers to their adoption.

For example on the road network, congestions emerge if too many car drivers choose the same route. Congestions mean not only a time loss for the traffic participants. Stop and go traffic does increase air pollution, noise levels and fuel consumption, and thus carbon emissions. Information and communication technologies can help drivers to avoid traffic jams by providing news about the traffic density of the roads ahead. See a more detailed description of Intelligent Transportation Systems (ICT, ITS) in Chapter 3, Innovative Technologies.

1.2 Demand Management Models

Demand management and land-use planning has recently been recognized as a tool and research area for sustainable urban development.

The previously mentioned 2011 EU White Paper says: "...Demand management and land-use planning can lower traffic volumes. Facilitating walking and cycling should become an integral part of urban mobility and infrastructure design".

Demand management has become a research topic of the EU's 7th Framework Programme, the major scientific funding framework of the EU. In the Workprogramme, which describes all projects to be funded, area 7.2.3.3 (Demand management) says:

"The objective is to promote a more rational use of the private vehicle and the use of non-polluting modes of transport through advanced approaches for demand management. Activities will include the real life testing of traffic restraint measures, parking management, the use of financial (dis)incentives and research on innovative mobility management, marketing and behavioural change schemes. Research will also cover the organisation and quality of urban transport, non-motorised modes and the efficient use of urban transport networks through intelligent information and communication strategies, services and infrastructures."

Demand management models have excellent short-term potential as they intend to shift transport demand to sustainable modes that are already widely available (for example, the bicycle, electric bikes and micro-cars). Demand management can help to avoid trips in the first place.

Demand management is generally implemented by local governments (cities or regions) with primarily local effects. The European-added value is that there is mutual-learning among European institutions and governments, and so successes are made transparent such that they can be transferred and repeated if appropriate, as is the goal of the ITACA effort. Many demand management methods can also be implemented in developing countries with lower financial resources, due to their potentially low implementation cost and high potential for effectiveness.

Within the 7th Framework Programme, the USEmobility project (www.usemobility.eu) sets out to study in-depth mobility behaviour. It particularly aims to find out why people decided to switch from pure car use to public transport within the past 5 years. USEmobility is an ongoing project. ITACA can already use and build on the first results being developed by USEmobility.

Concerning land use, one interesting Central European project, which is partially funded by the ERDF, is called “Urban spaces” (<http://www.urbanspaces.eu>). It has the goal to give universal guidelines on how to improve urban spaces and make them more sustainable. A part of the guidelines is concerned with connectivity and how to reduce the reliance on motorized transport.

Theoretical basics and best cases of demand management are described in Chapter 2. This chapter covers also ITACA approaches to transport demand management such as changing behaviour; changing land use; and changing supply – and thus demand. Pricing is another method of changing demand; presently the very large externalised costs of car dependency, including the potential future disasters to be borne of generations to come, are left unaccounted for. In this sense the ITACA efforts address pandemic market failures.

1.3 The Need for New Propulsion Technologies

Cleaner vehicles and alternative fuels are fundamental pillars in the European policy to decarbonise urban and regional transport and reduce local emissions. This assumption is being supported by several EU initiatives:

- In its EU 2020 strategy, the Commission proposes the Flagship Initiative “Resource efficient Europe”. This initiative includes proposals aiming at cleaner and more sustainable transport.
- The Framework Programmes for Research and Technological Development have financed projects for developing clean technologies for all transport modes. In order to facilitate applied research, different regulations have established Joint Undertakings for accelerating development of i) clean aircraft, and ii) fuel cell and hydrogen technologies including for transport.

Despite this legal and policy support, an insufficient market up-take of clean transport technologies has been observed to-date. New technologies, which have been developed over the past decades, have difficulties bridging the gap between demonstration and market uptake due to initial high costs of infrastructure and equipment which result from the lack of critical mass, fragmented markets, and a lack of internalisation of external costs in the present system of prevalence. Moreover, adoption of new technologies is not without direct and hidden environmental costs including carbon emissions, so great care must be considered when promoting new technologies.

The market uptake of clean technologies is supported in the European context by the following legislative acts:

- Clean road transport vehicles: The Directive on the promotion of clean and energy efficient road transport vehicles (2009/33/EC), the CO₂/cars Regulation ((EC) No 443/2009), setting standards for CO₂ emissions from cars, and EU legislation on type approval of vehicles to gradually reduce pollutant emissions.
- Greenhouse gas intensity of transport fuels: The Fuel Quality Directive (2009/30/EC) requires a reduction of the life cycle greenhouse gas intensity of fuels, by 6% by 2020, and sets out conditions for additional indicative 4% reductions.
- Use of alternative fuels: The Renewable Energy Directive (2009/28/EC), requiring a 10% share of renewable energy in transport by 2020, and the Directive on the taxation of energy products (2003/96/EC), enabling favourable treatment of alternative fuels substituting oil.
- European strategy on clean and energy efficient vehicles: The Commission Communication COM(2009)186 lays out an action plan on green vehicles, referring to the Commission intention to propose a long term strategy in 2011 in a Strategic Transport Technology Plan and in a Communication on Clean Transport Systems.

Recently, the EU White Paper, Transport 2050, “Roadmap to a Single European Transport Area – Towards a competitive and resource efficient transport system,” sets for urban transport, among others goals, a big shift to cleaner cars and cleaner fuels, halving the use of ‘conventionally-fuelled’ cars in urban transport by 2030; phasing them out of cities by 2050 with a shift instead to electric cars, hydrogen cars, hybrid cars, public transport, and to walking and cycling in cities; to achieve essentially CO₂-free city logistics in major urban centres by 2030.

These goals will be achieved, among other measures, by the development of an EU Strategic Transport Technology Plan (STTP) to cover the research and the effective deployment of new technologies. This Plan will be a major initiative to regroup/refocus transport research and development efforts in Europe, including the key areas of alternative fuels, new materials, new propulsion systems, and more, as well as specific measures to incentivise and facilitate the introduction of cleaner vehicles.

Obviously, for technological solutions for cleaner cars, no city can act alone. Here, the EU will focus EU research efforts, introduce EU-wide deployment strategies and the right market conditions to facilitate the take-up of new cleaner vehicles in cities.

In this context, there are several European programmes, projects and initiatives to promote sustainable mobility through the deployment of innovative transport solutions: CIVITAS, POLIS (European Cities and Regions networking for Innovative Transport solutions), CATCH (Carbon Aware Travel CHOice), CITEAIR II (Common Information on European Air), CITYMOVE, ERTRAC (The European Road Transport Research Advisory Committee) NICHES+, OSMOSE (Open Source for MOBILE and Sustainable city), and more.

ITACA is another step at both the regional and local level to contribute to the EU priority to reduce CO₂ emissions associated with road transport in urban and metropolitan areas by identification, assessment and exchange of innovative technologies and more eco-friendly fuels, taking into account realistic assessment of impacts, benefits, costs and requirements for supply chains,

barriers and gaps, R&D and Innovation priorities, and more.

ITACA partners have identified, analyzed and shared information and experiences about these issues, not only at a policy level, but also with practical applications and showcases related with the scope of the project. The ITACA project offers the opportunity to compare different visions and approaches for common mobility needs, adapted to the particular characteristics of each region. Details on new propulsion technologies and renewable energy concepts can be found in Chapter 3 and its related resource, Annex III.

1.4 Launchpad to ITACA

In the chapters and annexes that follow, a collection of best practices, theories of approach, and innovative programmes are described.

Chapter 2: Demand Management Models

Demand management, or mobility management, has the objective of promoting a more rational use of the private vehicle and the use of non-polluting modes of transport. Demand management is about changing people's behaviour and habits by providing information, incentives, disincentives, and more sustainable alternatives.

Facilitating a modal shift away from combustion vehicles, and in particular private combustion vehicles, in order to meet goals for improving health, access, mobility, and sustainability, has been a long-term challenge for cities around the world. Today with the mounting crisis of climate change, realizing this shift is an imperative.

In the pursuit of reducing carbon emissions and increasing energy efficiency, ITACA partners have pursued a variety of innovative programmes and projects from a mobility management perspective.

Of paramount importance and a specific goal of this project, is to analyze the true carbon reductions and related benefits of each project. A cost-benefit analysis can then be conducted, and strategic policy goals can be generated. The most successful projects can then be most reliably programmed for replication elsewhere. An accounting of best practices will help all bodies concerned to know where they stand on meeting critical goals such as carbon reduction targets.

Unfortunately, this level of analysis can be challenging and has not been conducted yet for most ITACA projects. Key to this analysis is knowledge of behaviour with and without the project, along with reliable, preferably validated, benchmarks for the carbon generation and other implications of each scenario.

Three general categories of management types are described here: Behaviour Change, Land Use Planning, and Transport Supply/Demand Management.

Behaviour Change

Any initiative seeking to directly change individual behaviour, in order to achieve ITACA goals. Changes in the use of transportation systems can come from the individuals themselves, through their choice of behaviour. Incentives are one means of encouraging new behaviour. True, actions which change supply, or which change land use, certainly change behaviour by their nature, but are not included here in this first of three sections; rather, they are included in their own sections, as follows.

Land Use Planning Policies

Any action changing the future of land use in an area, which by its nature and analysis, is projected to achieve ITACA goals. Shifting potential destinations closer to people's origins is surely a means of increasing their attractiveness. Proximity leads to much different choices in travel, and even if the worst choices are made within that new framework, because of the benefit of physical/spatial proximity, the shorter distance greatly limits energy expenditure and emissions, amongst other harms. As we see in the APEA Canteen project below, the biggest gains are to be made at short distances where walking and cycling become most viable, but only if most people are in fact close enough to do so.

Transport Supply/Demand Management

A third category is of course that of providing a new mix of options from the "supply" side (as in economics); this leads to an equal and opposite shift in demand, and thus again a shift in travel behaviour is realized. Thus here we discuss any action which affects supply, and therefore demand, in a way favorable to achieving ITACA goals.

Note that many projects use ITS/ICT technologies and management methods in combination. Some of the projects with a predominantly technological approach will be discussed in Chapter 3, but will also be mentioned in this chapter from a Demand Management perspective.

The successive Section 2.1 shall give a scientific background on the potential of behavioural changes in transport. It further links theoretical findings with the showcases and best practices examined in the ITACA project. As each showcase is different and has its own socio-culturally adapted approach, it has been decided to present them in detail in separate sections, classified by the categories in which they fit best. These are "Direct behavioural changes" (Sec 2.2) "Land Use Planning" (Sec 2.3), and "Transport Supply/Demand Management" (Sec 2.4). Conclusions and key findings of this chapter can be found in Sec 2.5.

2.1 How manageable is transport demand?

This section shall summarize theoretical and experimental findings on the capability and readiness of humans to change transport behaviour and under which conditions behavioural changes can be expected. ITACA showcases and best practices, as detailed in Section 2.2, are cited.

Changing the conditions under which people travel is the essence of transport management. As mentioned above, a change of conditions can be monetary incentives/disincentives (direct behavioural change), an offer of alternative destinations (land use planning), or an offer of new options in alternative transport modes (transport supply management), or any combination of it. The findings of this section are an attempt to quantify the potential of the different demand management approaches examined by the ITACA project.

2.1.1 Theoretical modeling frameworks

Transport is a multi-disciplinary field, including (among others) engineering, economics, and psychology. Each science developed their own theoretical framework to model, explain and predict transport demand and changes in transport demand. It is beyond the scope of this section to explain all variants and details of existing models. The theories explained in this subsection are in part a summary from the state of the art report of the USEmobility project (www.usemobility.eu). Aspects that appear to be relevant to understand demand management methods have been expanded and related to ITACA showcases.

2.1.1.1 Utility maximization models

The maximum utility theory stems from economic science and is by far the dominant theory applied in transport planning [1]. The basic hypothesis is that each transport user will always choose the one alternative from which he believes has the highest utility for him. In other words, while planning a trip, each traffic participant tries to maximize the transport utility for himself. The theory is based on the assumption that all users make *rational decisions*. This is why it is sometimes called the Rational-Choice-Paradigm of conventional planning.

Applied to the problem of how many transport users would choose a certain mode, it is assumed that users associate with each mode a utility and then choose the mode with the highest utility.

This sounds like common sense, but a major problem is to determine or estimate the utilities that users actually associate with each mode. And in particular: how are the different characteristics (or attributes) of a transport mode associated with the utility? The most common approach is to quantify the attributes and to define the utility as a linear combination of the single attributes. Below is a very simple example to illustrate the approach (in practice utilities can be much more complex):

If $T_{cartrip}$ is the time of the car-trip to work, C_{fuel} are the fuel costs for the entire trip and X_{car} is a variable that quantifies the convenience of the car, then the average utility of the car can be modeled as

$$V_{car} = -\beta_{11}T_{cartrip} - \beta_{12}C_{fuel} + \beta_{13}X_{car}$$

where β_{11} , β_{12} and β_{13} are positive constants (parameters that can be calibrated by means of surveys). Note that an increasing trip-time and increasing costs will actually decrease the utility. The average utility function for a bus would be

$$V_{bus} = -\beta_{21}T_{bustrip} - \beta_{22}C_{ticket} + \beta_{23}X_{bus}$$

where $T_{bustrip}$ is the trip time with the bus, C_{ticket} the price for the ticket and X_{bus} the convenience of the bus. Generally the convenience of the car is judged greater than the convenience of the bus, thus $X_{car} > X_{bus}$. The beta's are again constants to be calibrated by surveys. Once the utilities of all modes are known (here only car and bus), then the share of users who take the car or the bus can be determined. One of the simplest ways to do this is the so-called binomial

logit model. In this case the share of bus users P_{bus} and the share of car users P_{car} can be determined by the equations:

$$P_{car} = \frac{\exp(V_{car})}{\exp(V_{bus}) + \exp(V_{car})} \quad \text{and} \quad P_{bus} = \frac{\exp(V_{bus})}{\exp(V_{bus}) + \exp(V_{car})}.$$

It is apparent that the car share P_{car} increases with an increasing average utility for the car V_{car} and the bus share P_{bus} increases with an average utility of the bus, V_{bus} . In this way the model allows us to predict the mode share, dependent on the attributes of each mode.

The maximum utility theory can be generalized not only to any number of competing transport modes, but also any number of competing paths. The latter types of models are called path choice models.

Getting back to the demand management problem, one could for example increase the bus share by decreasing the ticket price C_{ticket} in one or another form of subsidies. This would increase V_{bus} and therefore increase its mode share P_{bus} . Alternatively, one could add costs to the car trip (for example with a road tax) in order to decrease the average utility V_{car} and the share of the car-mode P_{car} .

Despite the possibilities offered by maximum utility models, there have been many critics [10] stating that these models are unreliable in making long-term predictions, and that they are of little use in practice. Nevertheless, the maximum utility model is *de facto* the only recognized method that allows us to quantitatively relate cause and effect in demand management. The maximum utility theory can also be used as a qualitative tool to understand some basic mechanisms behind rational reasoning.

In summary, if we can quantify the increase/decrease of average utilities due to the demand management measure, then the maximum utility models could predict the change in mode share and ultimately the savings in energy consumption and reduction of carbon emissions.

Some practical hints:

- The utility function for each mode may have already been calibrated for your city during a recent planning process. These utility models could be used to estimate the effects of planned demand management interventions, for example road tax or parking fees.
- The artificial increase of the costs (and decreasing utility) of car traffic (for example by a congestion charge for cars), does not automatically increase the share of all other modes. There are two reasons for this desired effect may not happen:
 - The alternative modes have even a lower utility than the car. For example if the user does not find a direct train connection.
 - There is no alternative to the car for the user's origin and destination. For example no bike, no foot path or no bus stop.

- Moreover, through efficiencies and alternative solutions such as trip chaining, overall travel may decrease beneficially.

2.1.1.2 Models and findings from transport psychology

Transport psychology attempts to explain behaviours that do not fall under the Rational-Choice-Paradigm. A rational choice requires the knowledge of all objective information relative to a specific decision [2]. Often people do not make the efforts to collect all information on a particular trip. In other cases people simply act irrationally even though they have all relevant information. In marketing and advertisement it is well known that facts and figures are not the main drivers for decision making.

Amongst many theories that have been used to explain and predict mode choice, [3] is the “Theory of planned behaviour”, developed by Icek Ajzen in 1985. Applied to transport demand, the theory could be summarized as follows:

The intention to perform a particular behaviour, for example to change to a more sustainable transport mode, is a superposition of attitudes *toward the behaviour*, *subjective norms*, and *perceived behavioural control*.

The first element in the equation is the *attitude towards the behaviour*. The attitude may be the person’s conviction that it is a good thing to use public transport or a bike. Attitudes are plastic and are influenced by the media, the social environment, and from one’s own experience. Objective information like travel time, costs, etc., can also change attitudes.

The second element is made of *subjective norms*. The person validates whether a change to public transport or cycling would be regarded positively or negatively in the social environment. This is a subjective validation—it is what the person believes the social environment would think. Dependent on the person, the social environment can be one’s friends, teachers, colleagues, etc.

The third component is the *perceived behavioural control*. This is the person’s own judgment on how much effort it will take to perform the mode change successfully. Or in the extreme, what is the risk of a failure? For example, a French study showed that 23% of all who suffered a bicycle stolen said they gave up cycling entirely as a result [6].

Even though there have been efforts to quantify psychological models like Ajzen’s [5], they give mostly qualitative information. But even such qualitative results can give practical advice for a successful demand management plan:

- Changing attitudes: Actions should be undertaken to raise awareness of climate and environmental problem and to make clear which transport modes are the cause of the problems. This information should reach a large part of the population; people should start talking about it. However, general knowledge of the climate change problem seems to be already recognized by the majority in some countries (62% of a UK survey believed that “Individuals should try to limit their car use for the sake of the environment”. [4]).
- Changing subjective norms: Officials, leaders and other opinion multipliers should provide a good example and be consistent with what they are saying and what they are doing. In the public eye, bike counters

with a display have been installed in Copenhagen and other cities to show that cyclists are not alone. Bicycle events and festivals are more important for setting norms than changing attitudes (a person who will begin cycling is likely to already have a positive attitude).

- Changing perceived behavioural control: For example training programmes to ride a bike in the traffic, how to lock a bike properly, and how to repair a bike, would be important measures. It would make potential bike users more confident with their own abilities to use the bike. Regarding public transport, good passenger information strategies should be employed so the unfamiliar passenger feels confident to navigate through the public transport network. Advanced traveler information systems (ATIS) are expected to have a positive effect, but even simple measures like a map with all public transport lines at each stop and station and with the sticker “You are here” would be of tremendous utility, but are not yet standard in many European cities.

Transport psychology has also identified other values that play a significant role in behavioural change: moral beliefs, self-identity, regret, affect, or habit; for a summary, see [5] and references herein. Transport psychologist Stradling made extensive surveys on travel behaviour in the UK [4] and found that people use traveling as a form of self-expression; it is affective. Transport mode choice is a part of their life-style, just as clothing styles. He further states that their values can vary over time and there are moments when people reconsider their choices. Stradling says that “people are simultaneously adaptable and resistant to change. They can and do cope with changing circumstances or operating conditions (for example new car fitted with driver assistance); they value the comfort and convenience of habits and routines, having typically expended some search effort in acquiring them.” His conclusion that there is a fair chance to make people change their travel behaviour, but they won’t change instantly and they will only change permanently if they find the new choice convenient and develop an affective relation.

Psychologists have identified situations in which people are more likely to change their behaviour: The hypothesis has been verified that context change enhances the likelihood that important values are considered and guide behaviour. The study described in [11] surveyed employees at the University of Bath, asking three questions: (1) “Are you using the car for work-trips?”; (2) “Do you have environmental concerns?”; and (3) “Have you recently moved to Bath?” The outcome is shown in the figure below. The result is striking as environmentally concerned employees already living in Bath use the car twice as much as their environmentally concerned colleagues who recently moved to Bath. The explanation given in this study is that employees who moved apartments (changed their context) are more likely to reconsider their attitudes and as a consequence change their behaviour (stop using cars).

Context change	Environmental concern	
	Low	High
Recently moved	0.73a	0.37b
Not recently moved	0.54a	0.64a

Table 2.1.: Share of car-users of the university employees in Bath, UK, from [11]

A practical recommendation for a city would be to provide newly arrived residents with information about the public transport network, the cycle path network, car-sharing opportunities, etc., in order to maximize the potential of the change in context, and to set the social norm that alternative transport is valued and supported in the new community. There may even be a chance that the new residents would choose an apartment with a location that is well served by public transport, or near a cycle track. Many cities already give such information to new residents, but again, no long-term studies are available as to whether these measures have been effective.

With regard to environmental concerns, there is the so-called “*low-cost hypothesis*”, stating that attitudes and moral beliefs are especially relevant when behaviour costs are low. In other words, if an environmental friendly option does only cost little more compared with the current choice (which is not environmental-friendly), then the user will accept the more environmentally-friendly option. In contrast, if the environmentally-friendly option costs much more (in terms of monetary costs, time or physical effort) then the user will not change. There is some statistical support for the low-cost hypothesis. For example, studies in Germany showed that students would prefer public transport that is less convenient than a car, if the fare is essentially free. On the other hand if there is no incentive, only a few users would give up driving a car for environmental concerns [4]. Therefore, making environmentally-friendly choices more convenient/less-costly – or nearly so – as harmful ones, is essential to successfully achieving policy goals.

2.1.2 The potential of direct behavioural change

Direct behavioural change means incentives/disincentives are given directly to the transport user such that she/he changes his/her personal mobility. The theoretical framework for this management approach is clearly laid down in the utility maximization models and rational choice paradigm as explained in Sec. 2.1.1.1. The increase/decrease of monetary costs or travel time, and the subsequent change in utility is expected to decrease/increase the share of the respective mode. Incentive/disincentive schemes that are implemented by local governments may also influence the subjective normative values, but there is no scientific evidence for this hypothesis.

The literature on congestion pricing, a leading example of such a scheme, is vast; see [7] for a recent review. In this subsection we raise the key relevant issues and experiences within the ITACA project.

The principle *forms of incentives* are:

- Subsidies for the use of public transport. For example reduced ticket prices.
- Premiums for not using a road. This can be interpreted as negative congestion pricing.

There are also non-monetary incentives like free access, or free parking, for low emission and/or car-pooling vehicles. In the United States, the High Occupancy Vehicle (HOV) lanes have received considerable attention and major investment. Such measures can reduce the travel/access time and/or cost for certain transport modes, which means again an increase in utility.

It is important to name also the “unintended” incentives for car-use:

- High fixed costs and low variable costs per km can be considered an incentive to use the car whenever possible.
- Free or low cost road parking on public spaces or free company parking spaces is an invitation to arrive by car.

The principle *forms of disincentives* are:

- Road tax (permanent fees for road usage).
- Congestion toll (temporary fees for road usage).
- Parking fees.

As non-monetary disincentives, access restrictions are a major category; e.g., limitations for when and how cars and motor bikes may enter a certain zone of the city. Access restrictions will result in an increase in average access time, which decreases the utility for the vehicle subject to the restriction.

Apart from the incentives/disincentives scheme it is worth mentioning educational programmes which aim at teaching people how to cycle or how to walk. Also this measure can be classified as direct behaviour change. Educational programmes are particularly effective (and practiced) at schools. The ITACA showcase Pedibus (section 2.2.3) belongs to this category. However, long term studies on behavioural change due to educational programmes are time-consuming to conduct. Still, it is thought to be effective because they raise the confidence of the children to manage the trip to school by bike or on foot (generates positive perceived behavioural control).

2.1.2.1 Incentive schemes versus disincentive schemes

In general, incentive schemes use collective money (taxes) that is transferred to individuals, while disincentive schemes transfer money from individuals to the collectivity. From a maximum utility theoretical point of view, incentives and disincentives are symmetric measures, which means that incentivizing one mode or discouraging all other modes through charges will give the same result.

However, this is in stark contrast with the realities experienced in Europe: The political and social acceptance for incentives and disincentives appears to be quite different from country to country: Larger urban congestion charges have only been implemented in England and Scandinavia, not without some controversy, but with very successful outcomes. There appears to be a cultural resistance to congestion charges in continental Europe which has impeded the spread of this type of measure. It is important to make clear that there needs to be a fine line drawn between permanent road taxes, which should cover the construction and maintenance of the road (Marginal cost pricing) and congestion charges. Road taxes, in one form or another, are accepted and common in many continental European countries, whereas congestion charges are perceived as punitive measures and have often been turned down by the governments, see for example Paris [8]. On the other hand, car parking pricing as disincentive schemes can be found anywhere in Europe.

2.1.2.2 Incentive schemes

Incentive schemes are quite common in most European countries, mostly in form of fare reduction schemes of public transport. They have also been a basic instrument of the Regional Mobility Plan and the Regional Integrated Transport plan of the Emilia-Romagna Region (see showcase sections 2.2.1, 2.2.7).

Schemes with reduced ticket prices for public transport have been in place since many years, but in most cases a strong social component: families, elderly or children receive ticket price reduction (Or travel for free on public transport such as pensioners in the UK, who have free access to busses (but not trains at present). The true innovation is to extend the reduced fare tariffs to ordinary employees and workers in order to increase the share of public transport. The number of employees making use of this scheme has increased significantly as shown in section 2.2.1.

Another type of incentive scheme is to pay a reward to people for not travelling during rush hours. The reward is approximately 4€ per day and a maximum of 100€ per month. But it seems to be enough to convince many automobilists not to drive during rush hours (reductions between 20% and 60% of traffic flow on different sections of the highway). For implementation details, see Sec. 2.2.5 Avoiding rush hour (Spitsmijden). The high acceptance for this scheme cannot be fully explained by the reward of 4€ per day. It is more likely that the effect of the *low-cost hypothesis* is an additional if small motivation, and partially compensated extra efforts to do something good to the environment may compound or magnify. The report on Spitsmijden mentions that many people liked actually the off-peak driving and would continue to do so even without being rewarded. But no numbers are available yet. Despite the success of the scheme, where applied, it remains to be seen whether it can be extended to all urban areas or if the costs could not be spend better in sustainable alternatives.

2.1.2.3 Disincentive schemes

Congestion charges and parking pricing are the most prominent forms of disincentives to use the car, or to use the car during peak hours. The goal of congestion charging is to lower traffic flows during peak hours. Parking pricing is to discourage people from entering the city by car. Following the maximum utility theory, one could bring the car traffic to zero by charging high enough fees. However, in practice there are a number of severe limitations [7]:

- *Fairness issues:* There are numerous stakeholders involved with urban transportation. Any change that is viewed as adding costs to transportation will be viewed by some as punitive and unfair, and these groups may then appear as vigorous opponents to any plan that raises prices.
- *Equity issues:* If citizens perceive congestion charges or high parking fees as a discriminatory policy against the poor or the elderly or other disadvantaged groups, then the public -- including PT commuters -- may reject the scheme. This is why handicapped are usually excluded from charges. Still the decision how many low-income persons can no longer afford to use the car is a delicate political compromise.
- *Low cost, sustainable alternatives:* congestion charges and parking fees are acceptable if there are low cost alternatives, such as public transport or safe bike paths. Without sustainable alternatives, the charging system is perceived as money-generator for the municipality and is likely to be rejected.
- *Zero cost road alternatives:* If there are alternative roads available that are free of charge, then the price of the congestion charging scheme is very limited, as drivers would start using smaller roads (in the worst case residential roads) to reach their destination without being charged. This is counterproductive to the original goal of congestion charging. Congestion charging requires that there is a strong external to internal traffic and the main access roads are without alternatives. As for example in Tokyo, the congestion charging scheme has been turned down because the uncontrollable internal --to-- internal traffic has been significantly high [7]. Also in Paris the effectiveness of congestion charge is limited due to zero cost alternative roads [8].

London has introduced its congestion charging system in 2003, see signpost and zone in Figure 2.1:

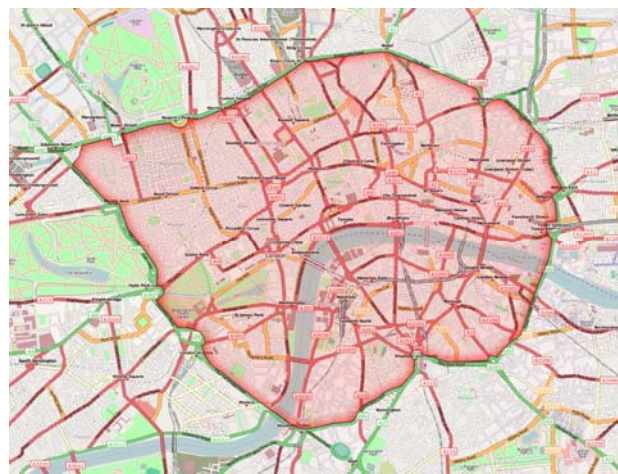

Figure 2.1: Congestion charge sign and area with congestion charge in London, UK

The traffic volume is monitored on representative roads on a continuous bases [9]. The figure below shows how volumes of traffic entering the charging zone are distributed across the day. Noting that the 'counting day' extends either side of the charging hours (from 06.00 to 20.00 hours) and that the four lines represent 'annualised' counts for 2002, 2003 and 2004 and 2005 (comparable Spring and Autumn counts only), the sustained effect of charging in reducing traffic levels is clear, as is the continuing trend of small year-on-year reductions in traffic entering the charging zone. Similar profiles can be observed for traffic leaving the charging zone. During the day a decrease due to the congestion charge of approximately 10%-20% in traffic flows is observable.

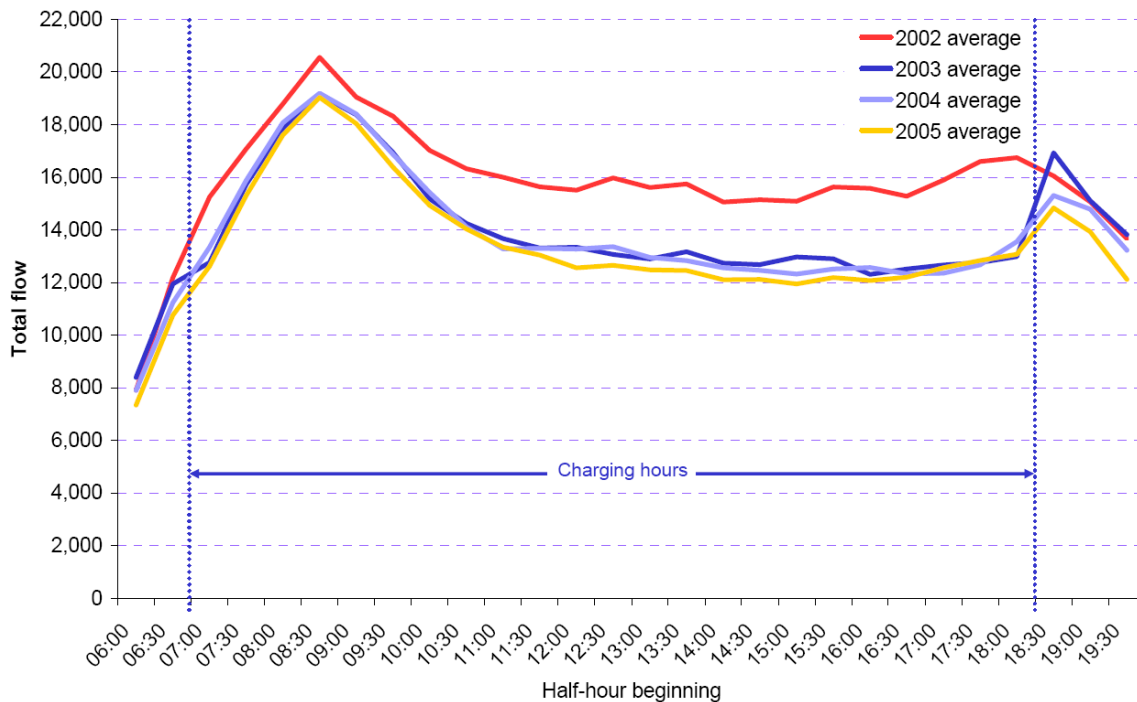

Figure 2.2: Traffic entering London's charging zone by time of day. Annualised weekdays for 2002 (pre-charging), and 2003-2005 (post-charging), all vehicles

The estimated overall annual vehicles kilometers driven within the charging zones shrunk from 1.64 Million km before the introduction to 1.45 Million km after the introduction in 2003.

This is a reduction of vehicle km by approximately 15%. Note that the reduction of private (chargeable) vehicles has decreased by 30%, but there has been a sharp increase of non-chargeable vehicles such as taxis, buses and coaches which partially compensated the reduction in vehicle km of private vehicles [9].

The congestion levels within the charging zone, measured in excess delay time per km, reduced by approximately 26% with respect to pre-charging levels (see Fig. 2.3, below).

Another positive effect is that the bicycle share on roads jumped from 4% to 7%, post-congestion charge.

Turning to the ITACA best practice case in Stockholm, Sweden, traffic flow reductions could be observed (around 20%), which is consistent with the case in London, see section 2.2.4. Technically, Stockholm has ideal conditions for congestion charging as the access roads are easily controllable (bridges!) and there are no alternative uncharged roads. Instead, there is a quality and dense public transport network as alternative, which should guarantee that there is a net reduction in CO2 emissions-- as many of those who stopped using the car to enter Stockholm start using public transport.

of the transport offer influences land use and vice versa. Thus, LUTI models could be used to validate the future impact of different transport scenarios on land use. At this point we would like to refer to the TraCit Power Project [<http://www.tracit.org.uk/>], a sister project to ITACA under the POWER programmes, where LUTI models have been explained in greater detail and proposed as a decision-making tool. The LUTI model is described in summary template form in Annex I.2, under Land Use Planning Policies.

Clearly, LUTI models are an instrument for long-term strategic planning. Here we shall summarize some land-use characteristics that are known to have positive effects in terms of sustainable mobility and carbon emissions:

- High urban density and corridors
- Mixed land use
- Accessibility for soft modes (walking, cycling) and green networks

It is worth noting that transit-oriented land use and planning is not only about shortening travel distances and enabling soft-modes. There are also aspects such as community life; safer neighborhoods; infrastructure, resource and energy savings; and improving the overall quality of life in public spaces. Below we look more closely at the transport aspects of land-use planning in particular.

2.1.3.1 High urban density and corridors

It is basic physics that high population densities shorten distances. What is often overlooked is the tremendous effect of this simple logic to annual traveling distances, mode choice and annual energy usage for transport. The Figure below from Peter Newman [11] illustrates the relation between the area per person (inverse population density) and transport energy usage for different cities around the world. Even though one should be careful on how the transport energies are obtained (with which data and underlying assumptions), the overall correlation is striking: US cities (in blue) use up to four times as much gasoline per person than denser European cities (in red).

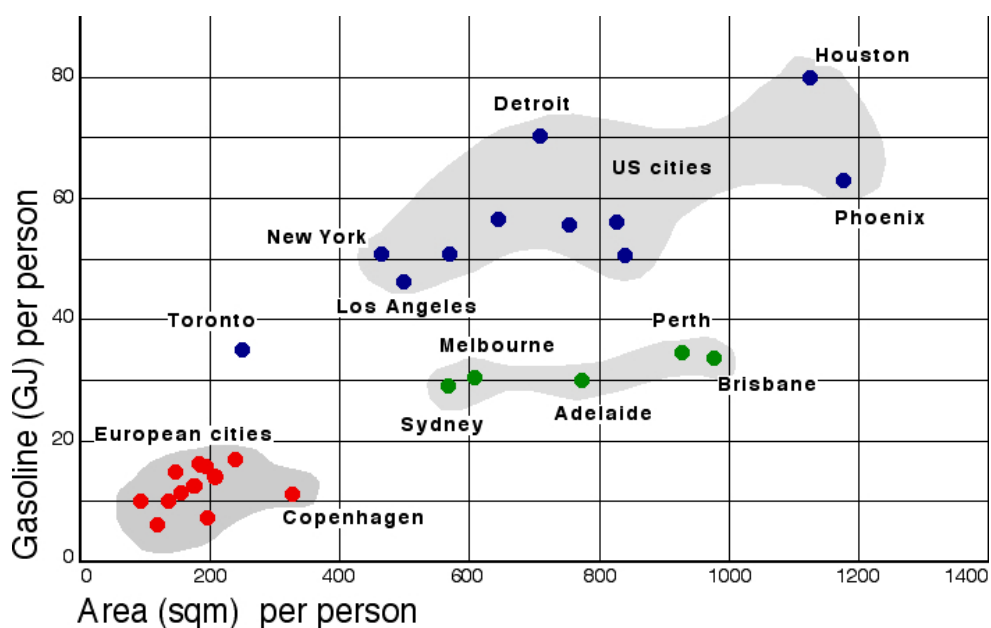

Figure 2.4: Gasoline consumption per habitant in different cities, from [11]

In order to boost the effectiveness of line oriented public transport, it is of great advantage to plan high urban population densities around corridors. Different corridor configurations are thinkable, dependent on the layout of a city; see Figure 2.5, below.

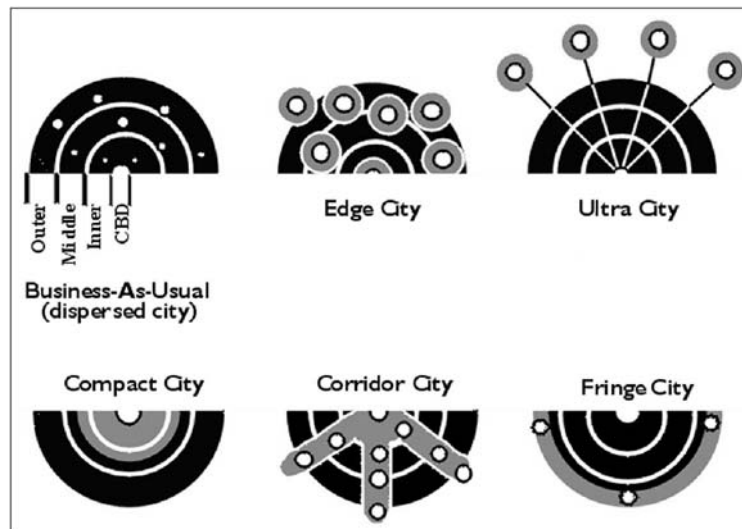

Figure 2.5: Urban density patterns (high densities in grey) Credit: Peter Newman: *Reshaping cities for a more sustainable Future* (1998)

Even if there are few new city developments, land-use policies can change the urban fabric through densification in certain areas and reducing use of others. One mechanism that is used in some places is the Transfer of Development Rights, in which density bonuses for infill development are granted in exchange for accomplishing another land use goal somewhere else, for example, restoring a natural feature such as a creek; renovating or relocating an historic building; or removing structures such as blighted buildings, excess parking garages, or those posed with a disaster risk such as housing in a flood zone.

These measures would usually not be a task of transport management but a part of a long term strategic transport plan. An example for such a plan considering densification is the ICATA show-case Master and Environmental Plans, Lidingö, Sweden, see Section 2.3.2.

2.1.3.2 Mixed land use

A mix of functionality assures that people find destinations and can accomplish activities locally and are not “obliged” to travel to other parts of the city, presumably by car. The paradigm of zoning, as practiced excessively in the United States, has the opposite effect: it divides the city in zones reserved for residential settlements, industry/commercial and shopping/recreation. The zoning approach has the intention to “protect” the residential areas from noisy and polluting industry and busy shopping centers. But with more and more industries in Europe being de-facto smoke-less, such paradigms are no longer valid and it is possible to mix offices and residences at least to some degree.

Even though it appears that changing the functional use of a city is subject to a long term master plan, small changes can make a big difference as demonstrated by the ITACA show-case the PIANO canteen: with the help of the city, a canteen has been opened at an industrial site near Gabbice, Italy. This

small “diversification” of land use has allowed the workers of this site to stay there for lunch, instead of going home for lunch (mainly by car). Many workers welcomed the new opportunity and many daily car-trips could be saved. The interesting aspect of this project has been that the private investors did not believe that a canteen at the industrial site would be profitable.

2.1.3.3 Accessibility for soft modes

A higher accessibility for pedestrians and bike can be achieved through various ways: Either new infrastructure is added (footpath, cycle path, pedestrian crossings, safe bicycle parking) or the car traffic is calmed or completely eliminated in the respective area. Demand Management is mainly concerned with the latter methods (i.e., motorized traffic calming and reduction of parking). Reduction of motorized traffic flows (shielding) is a prerequisite and overlapping with the congestion charging and traffic restriction methods explained in Section 2.1.2. However, traffic-calming or even car-free areas takes the traffic reduction a step further, as they limit speeds and change priorities. There seem to be different preferred approaches in European cities on how to make motorized traffic on a street more safe and humane – and compatible with the speed of pedestrians and cyclists. There are principally three lines of thinking:

- *Traffic Calming* by means of limiting conventional speeds to walking speed and ensuring absolute priority for pedestrians and cyclists.
- *The Shared Space Approach*: traffic calming achieved through negotiation between equal traffic participants, relying on uncertainty to change behaviour. With shared space all traffic signs including traffic lights are removed, and physical separation may be removed as well (e.g., no curbs or lane markings). Shared space experiments have been implemented in Germany, Netherlands, Sweden, and the United Kingdom. The main shared space achievements so far have been a notable speed reduction in many places. It is claimed that shared space works better than speed limits. However, there are critics, mainly from associations for the blind, who rely on physical markers for safe navigation, and some complaints of motorists being too aggressive.
- *Carfree Zones*, where the access of cars and motorbikes is severely restricted (for example, for residents, to unload only) and completely banned in certain areas. Residents with cars would leave them in car-parks located at the periphery of the zone. Carfree zones in Germany, Vauban achieved a radical change in mobility: 70 percent of Vauban’s families do not own cars, and 57 percent sold their car to move here. However, it is worth to note that Vauban has been carfree from the beginning (after the conversion of military zone). This means all citizens of Vauban live in a carfree environment by choice. Converting existing urban areas into carfree areas may not have such tremendous effects (i.e., more people would remain car owners).
On the other hand, the share of carfree households in larger cities is significant; a study commissioned by the German Ministry for the Environment (BUM) [3] revealed that in Germany and Switzerland the

share of car-free households in cities above 500,000 inhabitants is approximately 40%; a stated preference survey conducted in 5 larger German cities around 2/3 of 1-2 person households is interested to live in a car-free settlement. In fact, none of the 8 investigated car-free quarters have marketing problems.





Figure 2.6. Top: Shared space in Drachten, Netherlands. Bottom: carfree quarter in Vauban, Germany

Making more public space accessible to the people is a delicate issue and its implementation and rules depend on local traffic conditions, land-use patterns and practices culture. The acceptance and support of the local population is essential. As for example, severe traffic access restrictions are justifiable in historic city centers as demonstrated with the ITACA best practice in the historic center of Bologna, for details see Sec. 2.2.6.

2.1.3.4 Modern Carfree Cities

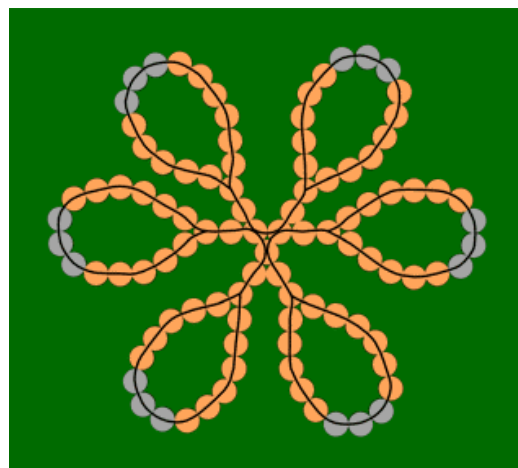

Figure 2.7. In a theoretical modern carfree city, walkable centers (left) are strung along high-quality transit corridors (right). Here in a city of one million persons the longest door-to-door travel time is predicted to be 35 minutes. Enormous amounts of land, energy and carbon emissions would be saved, in addition to co-benefits such as active lifestyles, social integration, and reduced air and noise pollution [18]

If reducing automobile use is the primary low-carbon transport measure, then a city entirely without cars, relying very much on land use planning to achieve access along with mobility, is perhaps the ultimate realization of this goal. In theory, a modern city could not only survive, but prosper and thrive, with few or no private automobiles: a modern *carfree city*. This idea has been analysed through literature and a conference series, *Towards Carfree Cities*, now successfully concluding its tenth year. [17]

Detailed in two texts and a website by J.H. Crawford [18-20], the notion of a modern carfree city is made real through an analysed reference design projected to save tremendous resources, eliminate massive amounts of wasteful emissions, and even save 80% of available land. Yet, in a city of one million, the longest door-to-door trip would be under 35 minutes. Carfree areas are already in demand today for the quality of life they offer (see the above section; 2.1.3.3, *Accessibility for soft modes*, for example), but such a city would also serve as an equalizer; in a carfree city, non-drivers gain the promise of maximum accessibility, particularly valuable to the young, the old, and people with disabilities who may not be able to drive when necessary.

Although this reference design is theory, any modern city, without austerity measures, can through a combination of land use and demand management actions, set a course for a more sustainable city based on sound, proven planning principles, without having to gamble on a space age future *à la The Jetson's*. Rather than hoping technology can allow the private automobile model to continue, a safer course would seem much more prudent.

By relying instead on walking, coupled with superior mass transport and bicycling, with aggressive provisions allowing local solutions to residents' needs, piece-by-piece a more robust and economically sound city can emerge, perhaps more quickly than easily imagined, if market forces are allowed to create a renaissance new offer of land use and transport.

The final piece of mass transport in this hypothetical lowest-carbon solution would almost assuredly include the tried-and-true technology of electrified mass transport, a mature and highly energy-efficient, potentially zero-emission technology. If renewable energy is employed, we rapidly approach a zero carbon urban transport. [21]

In the interim, the abstract model of a carfree city using electrified mass transport as its mobility backbone remains a benchmark in aspirations for success in reducing carbon and creating more livable, more sustainable, healthier cities with more robust, lower-carbon economies.

2.1.4 Transport Supply/Demand Management

Creating new sustainable transport alternatives is of paramount importance in case the only choice that people is a less sustainable way to travel -- or if making a more sustainable choice takes considerable efforts. If the utility gap between the less sustainable solution and the sustainable solution is too large, then it will be difficult (or expensive) to convince users to choose the sustainable alternative (See Section 2.1.1.1). The low-cost hypothesis says that few people will make a lot of efforts for environmental reasons or for a common benefit (see section 2.1.1.2).

Some mobility management programmes are centered around a new transport supply offer. These are the ITACA projects detailed in Section 2.4.:

- The green parking initiative provides new parking space (Sec 2.4.1)
- The province of Ferrara has built bicycle path (Sec 2.4.3)
- The various bike sharing initiatives introduced public bikes and stations (Sec 2.4.4)
- The CONCABUS (Sec 2.4.5) and the Workers bus in the APEA project will provide new on-demand type bus services (Sec 2.4.6).
- The Monitoring programme of ERR is based on a new car-sharing fleet (2.4.7).

In some previously mentioned ITACA showcases and best practices, an acceptable sustainable alternative has already been a part of the programme:

- The Emilia Romagna Mobility plan includes provisions for building new cycling tracks and new footpaths.
- The congestion charging systems in Stockholm, (but also in London) can draw on a dense and efficient public transport network.

If sustainable alternatives are difficult to access or to use then demand management alone is unlikely to be effective.

2.2 Showcases / best practices - Direct behavioural change

This section contains a comparative study of best practice and show-cases concerning predominantly behavioural change issues, where monetary incentives/disincentives are offered to the transport user in order to make more use of sustainable transport modes.

2.2.1 Emilia-Romagna Regional Mobility Plan



Goals: The project goal has been to reduce the use of private transport to travel to work while at the same time encouraging the use of collective transport and other means of transport associated with a low environmental impact.

Demand: Over 3,000 employees, located throughout the Region of Emilia-Romagna, are currently working for the Emilia-Romagna Regional Council.

There are also a significant number of visitors to the Region's offices.

Action: From 2003, the Regional Mobility Plan is considered "work-in-progress" and is continuously updated. The approach taken, aims primarily at influencing individual behaviour rather than relying on additional transport supply. However, as mentioned in Sec. 2.1.4, the implementation of smaller infrastructure projects have been necessary as complementary measures, when sustainable alternatives were absent.

The core of the plan consists of one incentive scheme and one disincentive scheme (see Sec. 2.1.2 for background information):

- The incentive scheme provides subsidies for the purchase of public transport tickets, in particular for employees who had specific family issues and/or school children. This means the sustainable objectives do also have a strong social component.
- The disincentive scheme has been implemented by introducing a small fee for the use of the Regional Council's own parking spaces, which have been entirely free of charge before the implementation of the scheme. Excluded are persons who practice car-pooling and who manage to travel with at least 3 persons per car. Again, social aspects have been taken into consideration as disabled persons and pregnant mothers have been excluded from paying parking fees.

The following complementary transport infrastructure and services have been provided:

- Access routes for pedestrians and cyclists to Regional offices throughout the territory. Measures include This includes the implementation of parking areas, antitheft and anti-vandalism systems.
- Reserved lanes for public transport, which decreased average travel time and therefore increased the attractiveness of public transport with respect to the car.
- Car-pooling and car-sharing scheme has been initiated to address employees without acceptable public transport alternatives. The effect of increasing the number of passengers per car saves energy and reduces CO2 emissions.
- Substitution of the Regional Council's fleet of vehicles with low to zero-environmental impact models.
- In a particular plan, pedestrian routes have been built to get employees to walk to work.

The plan of the pedestrian routes has also included a widespread information and publicity campaign where the audience is informed about various aspects of sustainable transport.

A centralized Internet site has been created, where employees can access all information on the Region's mobility initiatives. The Internet site has further been useful to establish a more generic communication link between the institution and the employees.

All mobility management activities have been integrated with the activities of

external bodies and businesses such as City Councils, Provincial Councils and Transport Companies.

A series of indicators have been identified to assess the efficiency of the strategies adopted, and to formulate corrective measures. Besides energy savings, the productivity of employees and travel-related stress have been important measures.

Results: Since the introduction of the mobility plan, the number of employees using public transport increased from a few hundred to 2,300 out of 3,000 employees. The increase in public transport uses results in a net saving of energy and CO2 emissions.

Lessons:

- It has been important to identify the employees specific needs
- Providing updated information and promotion on sustainable transport alternatives
- An important issue has been the domino effect of this programme on other public administrations and private organizations.

Links: <http://www.regione.emilia-romagna.it/mobilitymanagement/>.

2.2.2 Environmental Management and Sustainable Mobility of Health Care Companies in Emilia-Romagna

Goal: Reduction of regular work-trips by car of all employees of the Public Health Care sector; encouragement of the use of collective transport and other transport modes with low environmental impact (reduction of congestion as well as atmospheric and noise pollution).

Demand: Over 60,000 employees from 17 Health Care Companies located throughout the whole Emilia-Romagna region have been involved in this initiative.

Action: Similar to the “Emilia-Romagna Regional Mobility Plan” this plan includes (1) sensitively selected subsidy scheme in favour of subscribers to public train and tram/bus services, (2) small fees for parking, excluding disabled persons (3) car pooling and ride sharing schemes (4), improved bicycle parking, (5) access improvements for pedestrians, (6) low to zero-environmental impact vehicle lease and proprietary vehicles. (7) Provision of adequate information through internet sites.

2.2.3 Pedibus: providing a structured opportunity for elementary and middle-school students to walk to school together, in Emilia-Romagna.

Goal: To increase pedestrian mobility by teaching children to walk at an early age, to educate to respect the environment and to reduce the use of private cars.

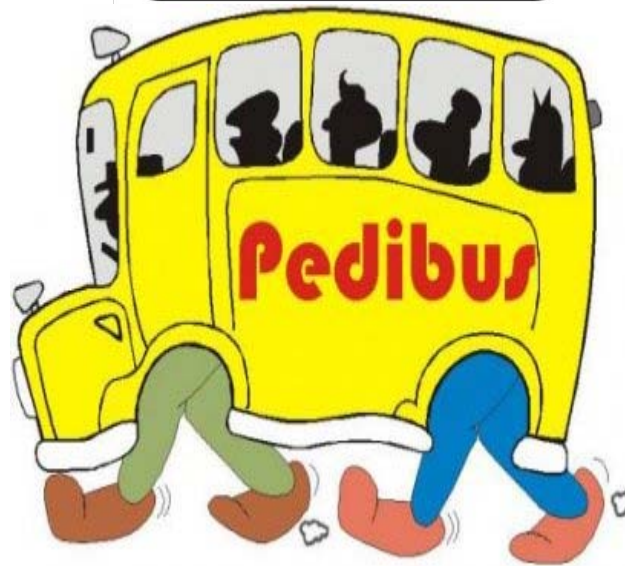

Demand: In the city of Rimini, and in the smaller towns of Verucchio, San Leo, Novafeltria, more than 1000 students are involved in the project. The project is being expanded expanded involving more and more students every year.

Action: The walking group mimics a bus (pedibus), with regular stops and a regular schedule. Parents and teachers, have the role of the “driver” in front and “controllers”. Just like a real bus, the pedibus departs from the terminus in one street and follows an established route to collect passengers at "stops" along the path, while respecting a fixed time schedule. Example cities from Italy include: Bologna, Ferrara, and Rimini. Surveys were used to assess potential demand.



Figure 2.7. Pedibus in Rimini, Italy [from <http://www.piedibus.it>]

In Rimini, the Pedibus is an initiative which gives opportunity to elementary and middle school students to be walked to school by their parents or volunteers who in turns will walk the students to school through safe paths. In Ferrara, the walking bus is permanent (all year-round school) for one elementary school. The project is supervised mainly by administration staff.

Results: The estimated reduction is -1% CO₂ per year. The costs of the project in Rimini were Euro 6.76k for the 2008/2009 school year, and Euro 5k for 2010.

Lessons: The pedibus concepts has become increasingly popular currently many Italian cities have copied this concept.



Links:

<http://www.piedibus.it>

Pedibus Rimini, <http://www.provincia.rimini.it/progetti/mobilita/index.htm>

Pedibus Ferrara, <http://www.ameliafrascaroli.it/joomla/home/progetto-piedibus.html>

Pedibus Bologna, <http://www.ami.fe.it/index.phtml?id=835>

Pedibus Turin, <http://www.iwalktoschool.org/whoswalking/italy.cfm>

2.2.4 Congestion Tax in Stockholm: changing behaviour through pricing, by introducing a higher charge for entering a congested area during peak times.

Note: Although this is a technology solution, it is primarily discussed here for its potent behaviour effects. Also see mention in chapter 3 “Intelligent Transport Systems, ICT applications” in the Innovative Technologies section, Chapter 3, section 3.3.3.1.

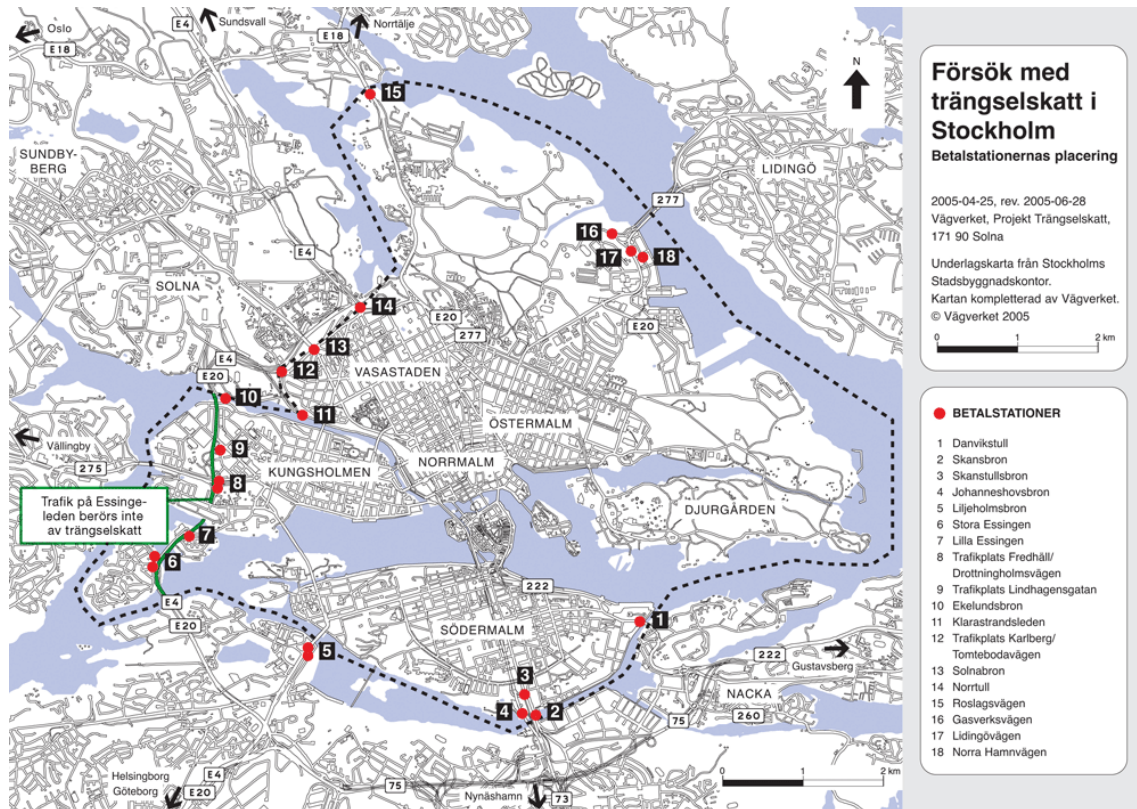

Figure 2.8. Map of the congestion tax scheme in Stockholm with reductions for the several links

Goals: To reduce congestion, emissions and to fund new roads in the region.

Demand: in 2006 Stockholm had approximately 400000 external-to-internal and internal to external car movements per day.

Actions: The congestion tax was implemented on a permanent basis on August 1, 2007, after a seven-month trial period between January 3, 2006 and after a referendum July 31, 2006. The tax is ultimately regulated by national law. Congestion tax is charged for Swedish-registered vehicles that are driven into and out of central Stockholm, Mondays to Fridays between 06.30 and 18.29. Some vehicles are exempt from congestion tax.

Similar to well-known implementations in cities like London and Manchester, the objectives of this practice are to reduce congestion and emissions, and to fund new roads in the region with the revenue generated. (It is worth noting that

funding new roads is a demand management measure that can increase the reliance on private automobiles, and thus increase CO2 emissions and other negative effects. Thus, funding alternatives to driving appears to be a better choice; but in any event, from a policy perspective, this can create a reliance on drivers that may ultimately run contrary to goals of reducing CO2 emissions.)

Vehicles are automatically registered at 'control points' during the periods when congestion tax is charged, with automatic number plate recognition (photographs). Each passage into or out of central Stockholm costs SEK 10, 15 or 20, depending on the time of day (approx. 1, 1.5, or 2€). The maximum amount per day and vehicle is SEK 60 (approx. 6.50€). The Swedish Transport Agency will send a payment slip to the owner of the vehicle at each month.

An exception exists for Lidingö, an island off Stockholm, with its only access to the mainland through the congestion tax affected area. Because of this, all traffic to and from Lidingö and the rest of Stockholm County is exempt from the tax, provided that one passes one of the Ropsten bridge abutment (the mainland side of the bridge) control points and some other control point within 30 minutes of each other.

The Essingeleden motorway, part of European route E4 that goes through the congestion tax affected area, is also exempt, as it is the main route bypassing central Stockholm, with no other viable alternatives nearby.



Figure 2.9. A control point of the congestion tax system (to Essingeleden)

Results: The congestion tax has significantly reduce the number of passenger car trips in Sockholm. The graph shown below compares the number of daily passengers travelling to and from Stockholm before (year 2005) and after (year 2006) the introduction of the congestion tax scheme. The annual reduction of external-internal road traffic has been reduced by approximately -20%. This caused a decrease in emissions of 10%-14% Picture from: [Gunnar Oderholm: European Green Capital 2010].

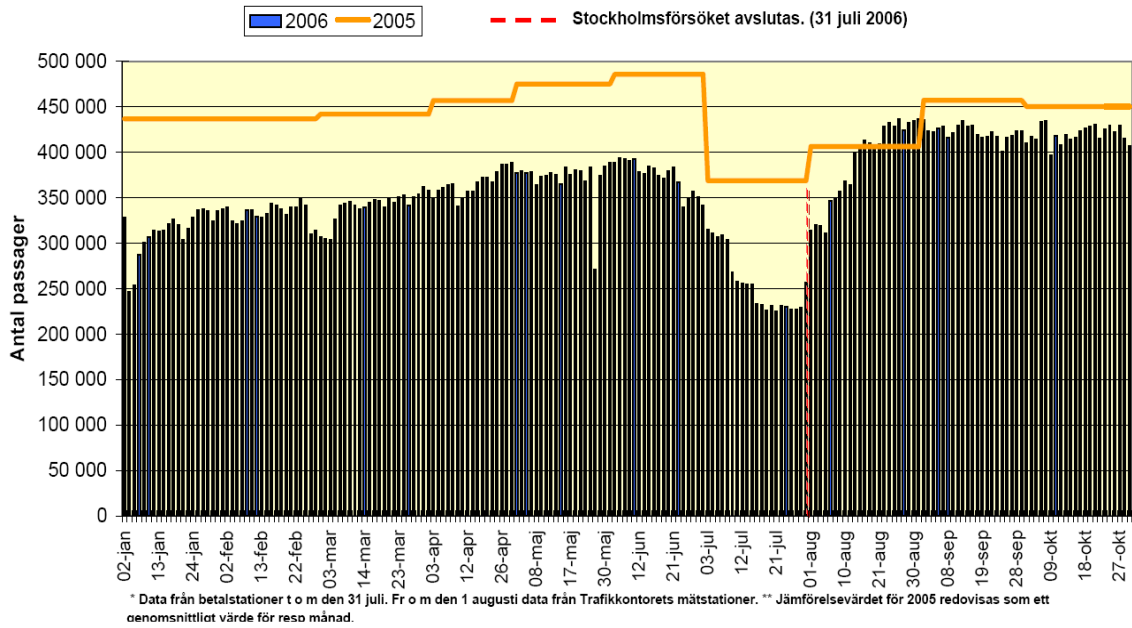

Figure 2.10. Reduction of daily traffic flows over one year, before the introduction (yellow) and after the introduction of the congestion charge (blue)

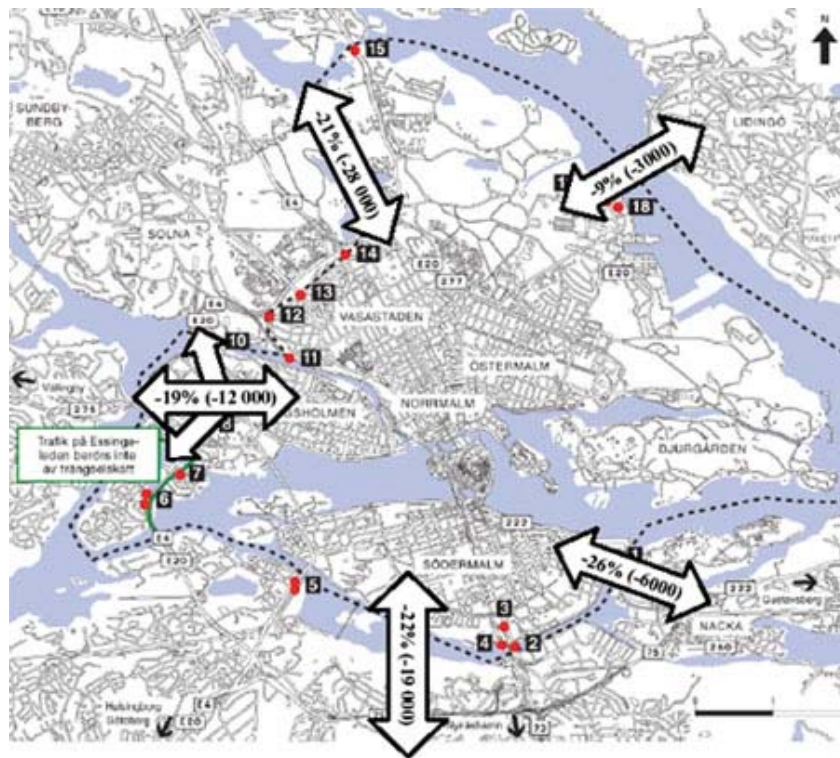

Figure 2.11. Reduction of annual traffic flows on a Map of Stockholm

Lessons: The scheme in Stockholm has been successful and in 2013 the same congestion tax system will be implemented in Gothenburg. A series of evaluations were made after the seven month trial period. All showed positive effects of the congestion tax. Traffic and emissions were reduced.

The groups of people who in general pay the most congestion tax are men, people with high income, couples with children and people living in the inner city or Lidingö.

Both people in general and business representatives have changed their view on congestion tax as the practice has continued from a negative to a positive stand. People change behaviour, and views (!) with time if pushing “the wallet buttons”.

It is worth noticing one pricing difference between the Stockholm congestion charge and the one in London: The maximum daily charge in Stockholm is 6.5€ (60SEK) while in London it is 9€ (8£).

Links:

www.transportstyrelsen.se
www.stockholm.se

Links to evaluations :

<http://www.stockholmsforsoket.se/templates/MakStart.aspx?id=300>

Downloaded some results.

http://www.stockholmsforsoket.se/upload/Infomaterial%20VV/Faktablad_Eng_Alm_v2_3.pdf

2.2.5 Avoiding rush hour (spitsmijden)

Goal: Reduction of congestion during peak hours through *financial rewards*.



Demand: The actual project in Brabant (with the cities Eindhoven and Den Bosch) has been started in 2010 with 700 participants; another 12.000 potential participants are invited. The project in Brabant will come to an end in 2012.



Figure 2.12. :Example of off-peak hour reward for the Zoetermeer, Gouda, Rotterdam, Haaglanden project

Action: The core of the Spitsmijden projects is that drivers are tempted to change their travel behaviour by financial rewards. In the region Noord-Brabant participants additionally are rewarded for taking part in the scheme with relevant travel information. Auto users who are common to drive downtown in rush hour were invited to participate in the project. The participants got a financial reward if they actually avoid driving in rush hour (Monday to Friday 07:30-09:30 a.m. and 04:30-6:30 p.m.) The reward could be €100 maximum per month. Spitsmijden in Brabant is not a trial like any other. This test focuses on urban accessibility and deployment of advanced traffic information on a handheld computer which participants receive in addition to the reward. With Spitsmijden in Brabant examines the impact of this information on the travel behaviour of participants. The actual behaviour of the participants have been monitored by in-car GPS.

The technical part of this showcase is described under “Intelligent Transport Systems, ICT applications” in the Innovative Technologies section, Chapter 3, section 3.3.3.1.

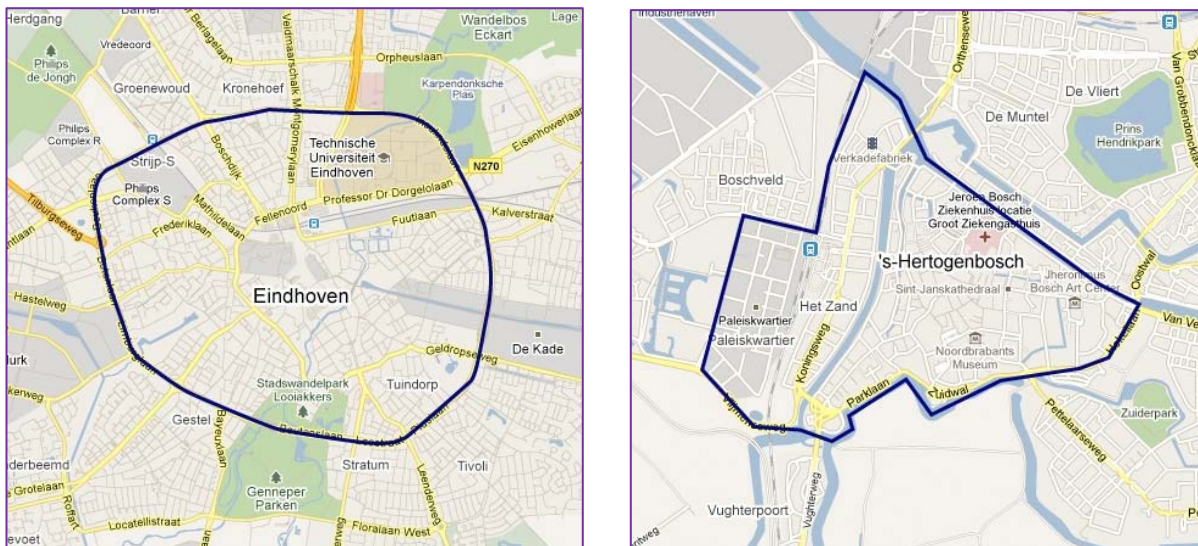

Figure 2.13. The two cities participating in the scheme: Eindhoven and Den Bosch

Results: In recent years, several successful experiments have been completed. Some motorists have chosen to drive outside rush hour, but a substantial group has chosen other kinds transport. The CO2 reduction of the project needs to be analyzed further, but preliminary results are outstanding. Two universities have been involved and have contributed analyses, with preliminary evaluations now available. The table below shows drops in peak hour traffic during the experiment. In some network segments, there have been reductions in traffic volumes of up to 61%!

Observation point	Direction	Zone	No. of cars passing at peak period			No. of cars passing per day (06.00-21.00)		
			Before rewards	During rewards	% change	Before rewards	During rewards	% change
Gouda	The Hague	Gouda-Zoetermeer	160	71	-56%	198	141	-29%
Zoetermeer	The Hague	Gouda-Zoetermeer	346	181	-48%	423	286	-32%
Nootdorp	The Hague	Zoetermeer-Den Haag	385	151	-61%	532	362	-32%
Nootdorp	Gouda	Opposite direction	313	243	-22%	474	378	-20%

Table 2.2. Number of cars passing during peak-period before and during the Spitsmijden scheme of Zoetermeer and Gouda. Source: [The effects of rewards in Spitsmijden 2 How can drivers be persuaded to avoid peak periods?]

Great effects were seen: just with small changes in the total volume, flows improved dramatically. This effect is clearly visible in (school) holidays. It only takes a little change, yet the effect on congestion is very high.

Lasting behavioural effects were found as well, with participants often testifying they were so happy avoiding rush hour with the new programme that they never would change back, not only because they save time and have a less stressful experience, but also because they feel they contribute to better accessibility and quality of life in their region.

The GPS system which monitors drivers for their rewards is multipurpose; given as an additional incentive to participate, as it also provides automated wayfinding services. Such services if successful potentially add to the behaviour change benefits by finding the most efficient pathways and reducing time spent lost.

Lessons: This policy of bringing people to the desired behaviour seems to be far more easy to introduce than road pricing. The peak hour avoidance schemes have been transferred to many cities in the Netherlands. Here are some examples:

Spitsmijden projects in Nijmegen, Zoetermeer, Gouda, Rotterdam, Haaglanden (The Hague region). Very successful was the project Smart Pricing Waalbrug in Nijmegen where 6,000 participants averaged 1,400 cycles per day peak hour avoidance realized. This effect has been visible as hardly any queues appeared on a busy bridge, not even during large-scale road works. Also on the A12

motorway between Zoetermeer and Gouda, the traffic has been reduced around major road works between 2008 and 2009, thanks to Spitsmijden. Ongoing project and projects in preparation are: SpitsScoren Rotterdam, SLIM Awards in Arnhem-Nijmegen and Spitsmijden Haaglanden around The Hague.

Links:

<http://www.spitsmijden.nl/resultaten/english/>

www.spitsmijdeninbrabant.nl

<https://www.spitsmijdeninbrabant.nl/pages/index.php?pageid=133>

2.2.6 Semi-pedestrian zone at Bologna's University quarter

Goal: reduction of car-traffic in Bologna's University quarter.

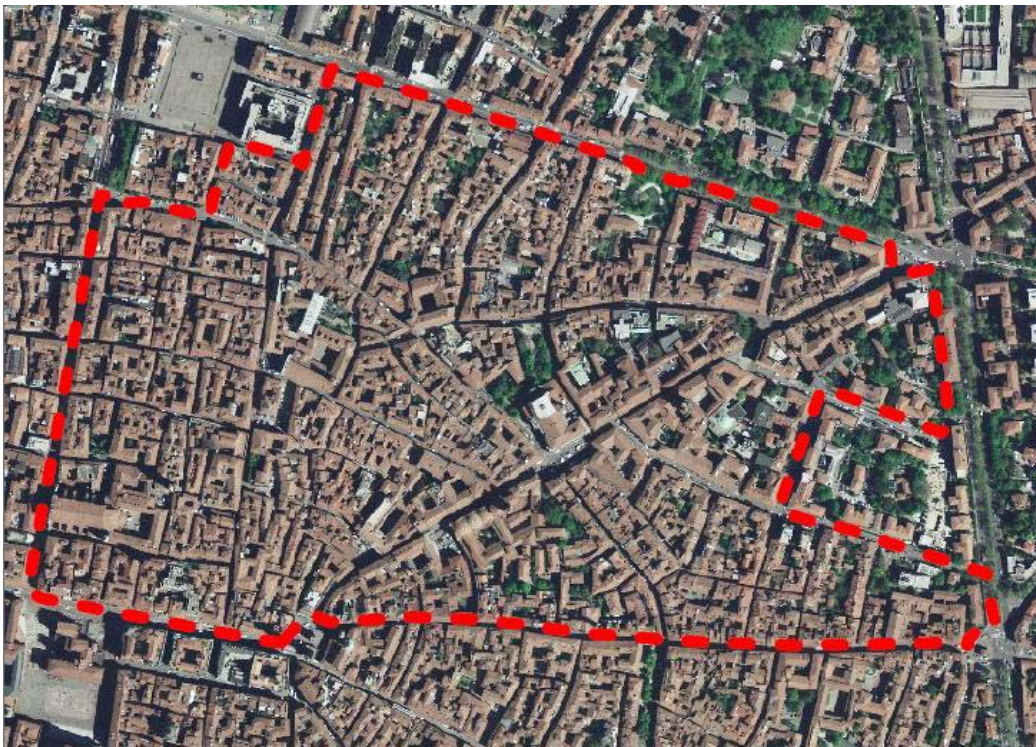

Figure 2.14. Car access restricted area, University of Bologna (in historic city center)

Action: Car access has been severely limited around the area of the old part of the Bologna University by means of different ITC access control methods: a camera surveillance with number plate recognition (RITA, SIRIO). Access control is enforced either by posting the fines automatically in case of violations, or by physical removable barriers. The pillars shown in the photo below robotically disappear into the street if there is a request from a car with permit to access this zone. Only a very restricted number of people have such access.



Figure 2.15. Photos show the different access control facilities: automatic pillars (left), surveillance camera on top of pole with parking sign (right)

Results: A reduction of 70% of the car traffic counts within the University zone. Semi-carfree zones with different access policies have been implemented throughout Bologna's historic center. The result has been an overall 20% drop in car-traffic since their implementation.

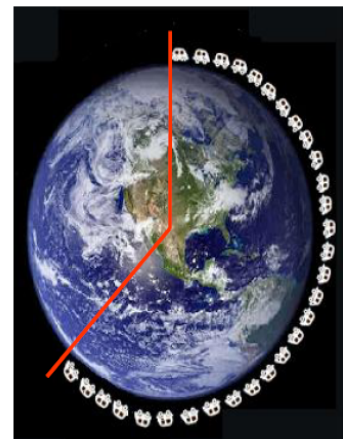
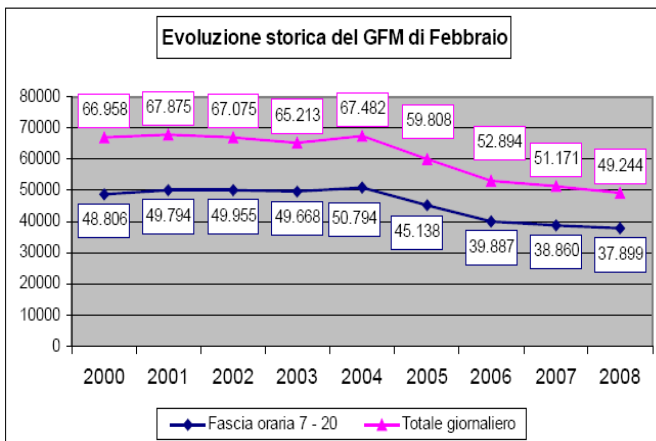

Figure 2.16. The figures demonstrate the drop in car traffic of the entire traffic restricted areas in Bologna's historic center in 2004 (left). This drop corresponds to 5,700,00 cars per year which corresponds to more than half of the earth's circumference when lined up (right)

2.2.7 Towards the new Regional Integrated Transport Plan, Emilia-Romagna

The Regional Plan for Integrated Transport (PRIT 98-2010) is the currently approved mobility plan of the Emilia-Romagna Region. The following description is preliminary focused on the mobility plan itself rather than on its contents.



Goal: Since the approval of PRIT 98-2010, regulations and guide-lines at European, national and regional level have changed. For this reason the Emilia-Romagna Region has decided to update the plan with the objective to provide a sustainable mobility in the region.

Actions: The following measures are proposed to ensure that the revised mobility plan will achieve its goals:

- Monitoring of the implementation of the Plan.
- Audit of the present situation
- Evaluation scheme for the effectiveness of the various options

There is a strong emphasis on delivering an integrated approach and on implementing European best practice. Furthermore an integration with other regional planning is important, such as the Regional Land-use Plan, Energy Plan, Environmental Action Plan, Integrated Coastal Zone Management ICZM, etc. Other aspects of an integrated approach are:

- transport innovation
- system integration and multi-modality
- safety

Citizens participation is another important idea. Buona mobilità (“good mobility”) is the slogan of this initiative where citizens as well as transport experts have been consulted to help drafting the update of the regional mobility plan.

2.3 Showcases / best practice - Land Use Planning Policies

This section contains showcases/best practice aimed at modifying the land use in order to decrease travel distances or to encourage soft modes.

2.3.1 Mobility management in APEA: placing a Canteen in an industrial area

Goal: Reduction of traffic generation during lunch time at the industrial area of San Giovanni in Marignano, the Province of Rimini, Italy.

Demand: Approximately 2000 workers at the industrial area of San Giovanni in Marignano – Cattolica.

Action: A canteen has been built and workers at the industrial site do not need to return home for lunch. A complementary measure, individually affirmed is that of the car pooling during the lunch break to go to the canteen. Through the survey on the field, it has been found that there are a high number of workers who implement the car sharing with colleagues to go to the canteen. This initiative is part of a wider mobility study, see [15].

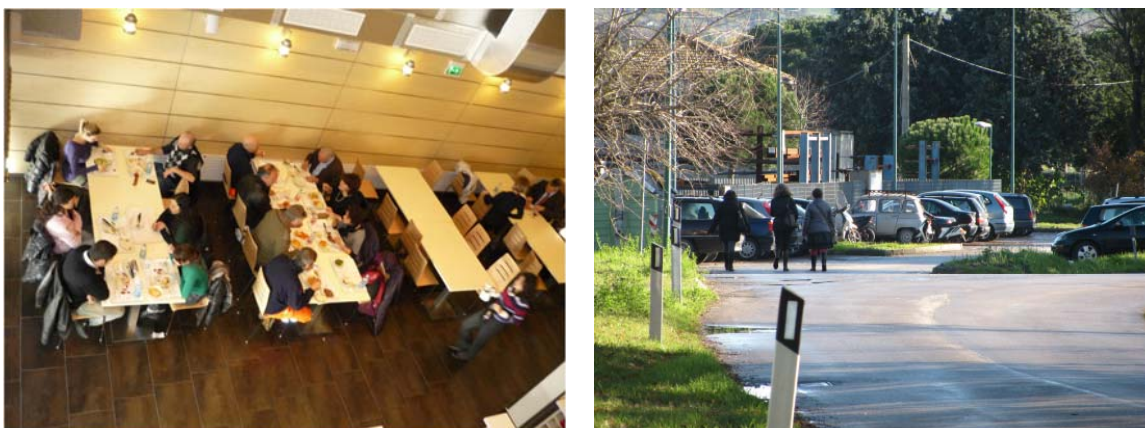

Figure 2.17. Photos of the canteen at the industrial area of San Giovanni in Marignano, Province of Rimini, Italy

Results: The percentage of workers who go home for lunch has fallen from 74% in the year 2003 to 57% in 2010, after the opening of the canteen. This means a drop of 17% work-home trips during lunch break.

Lessons: Due to the location of the canteen at the boarder of the area, workers of a lot of companies are constrained to use the car because the distance to the canteen would be more than 1.5 km. The small size of the canteen's parking, could have indirectly induced less car-use. A nice foot-path as a complementary measure would incentivize going on foot or by bike to the canteen. The new canteen has contributed to reduce the percentage of workers who come back

home for the lunch break. However, the non-central position of the canteen puts it in strong competition with the option of returning home by car, at least for those workers who live less than 5km away from the industrial site (approximately 46%). Due to this phenomenon, there are still car queues during lunch hours at the exit of the industrial site—most of them occupied with one person only.



Figure 2.18. Lunch break: cars still queue at the exits of the industrial area

2.3.2 Comprehensive and Environmental Plans, Lidingö, Sweden.

An island just across from Stockholm, Lidingö has engaged in an innovative planning process to improve its transportation profile through actions on many levels. Effectively a commuter suburb of Stockholm with high private automobile use, Lidingö has implemented a tiered planning process to address transport systems as well as land use, and meet an array of targets.

The rapidly finalizing Environmental Plan, a component of the Comprehensive Plan, addresses overall carbon emissions and other environmental effects on a criteria basis, and seeks to partner with residents to address these solutions not only through new services and infrastructure, but through culture change.

An innovative approach to collaborative planning is being employed. Lidingö seeks to change public behaviour through image creation, leading to identity-making. The new self-image of sustainable actions at the citizen level is honestly derived through asking the residents how the municipality can best support them in taking environmentally friendly actions. This dialogue approach is analogous to other successful practices such as Travel Choice or Travel Smart, in which citizens who wish to change behaviour are directly offered assistance in finding their own solutions. Facilitating self-discovery “sticks” where other measures such as one-way information campaigns can fail.

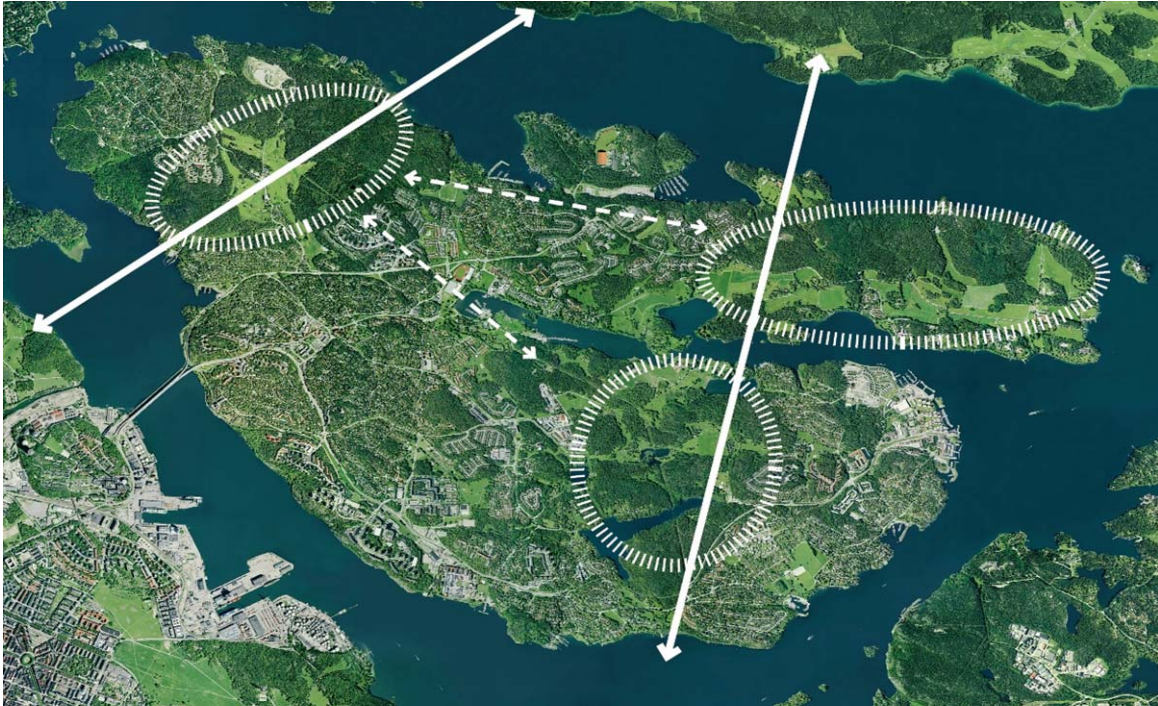

Figure 2.19. Lidingö protects green areas while densifying existing development, with increased provision for alternative transport. A host of related environmental policies are planned

Goal: To reduce private car use and GHG emissions; protect the environment; and improve quality of life. Sweden's environment policy is based on sixteen environmental quality objectives for different areas. The objectives describe the quality of the environment that we want to achieve. Based on these objectives the regional level is supposed to set interim targets and specific goals, it is voluntary for the local level. There is no system to set the objectives so municipalities use different ways. This approach follows the principals of a decentralised state. The regulatory framework such as EU level conventions, along with National, Regional and local targets are shown in the Figure below.

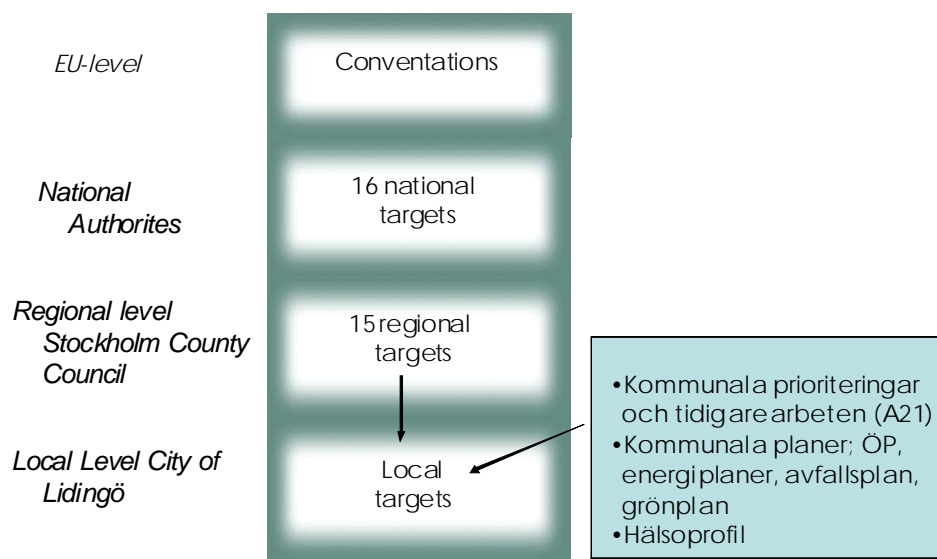

Figure 2.20. Regulatory framework of the Lidingö plan

Demand: Concerning the external communications and actions (principally towards the citizens), experience and science about behavioural change showed that behavioural change is intensely connected to identity making. The vision for the project was that all small environmental efforts in everyday life shall come together to an identity – a way of living environmentally smart. This vision had to start modestly with an integrated plan that painted the common picture. An overall theme is the preservation of nature and to make biodiversity available for humans.

Action: Planning for a responsible future.

Sustainable development: preserve land, water and energy, public transport, and densification:

- Better connections, both within Lidingö and to/from Lidingö
- Develop Public transport (tram, bus, boat)
- More integrated communications - smoother changes
- Park & ride – both for cars and bikes
- Improve the tram with new tramcars, better frequency and new route
- Development of bus traffic within Lidingö- to/from Lidingö
- Development of pedestrian-ways and bicycle paths
- Public transport by ferries

Results: Because the planning process is not quite finished, and results will emerge over years, it is too early to declare the results. However, prior to the implementation process, it is noteworthy that a model of evaluation was used in a large group (comprised of the project group, steering committee, and broader

project group) to prioritize the different environmental issues that were revealed in the mapping. The model includes a judgement of the seriousness/danger of the impact combined with the scope of the impact. It was made on a relative scale (e.g. among the issues concerned to Lidingö). Evaluating the risk through risk management methods will be applied. The evaluation is subjective and needs to be negotiated between all stakeholders.

One action connected to the plan and to ITACA is the bicycle campaign that took part in May this year. The biking campaign (“Bike!”) took place after the plan was sent out for consultation and was the first action that was communicated in connection to the plan. It was an appetizer or a sample of the new way of working with these questions. In terms of land use, it demonstrated that bicycling can be accomplished on a relatively small island. This was one step to enhance people’s engagement and to develop a positive attitude towards biking. The many activities included: handing out cycling maps and saddle wraparounds; bike tours with themes like nature, culture and training; an activity day in Lidingö Centre; and the inauguration of the bike counter. Driving to work with a car is a habit of many on the island. Therefore, four test families took the bike instead of the car during three weeks, and they were positively surprised; along with the results from surveys made during the campaign, the case for more bicycling is increasingly convincing.

Another outcome thus far was the identification of current special carbon emissions. This directly relates to the land use aspect of the island’s treatment needs. In concept, these areas can be addressed much more clearly when understood spatially.

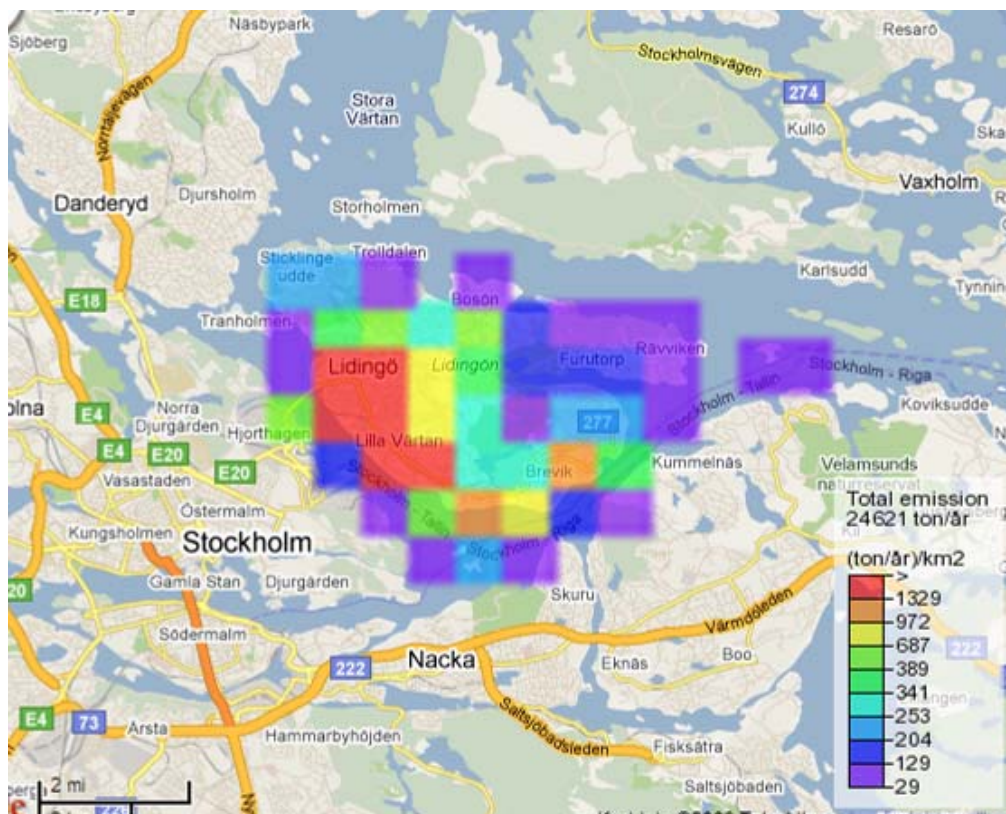

Figure 2.21. Existing conditions, spatial distribution of carbon emissions, Lidingö

Lessons: An environmental mapping was made in 2009, the mapping as well as workshops during the initial period led us to the decision that the Environmental Plan needs to have an integrated approach.

The mapping and workshops showed that the municipality could cooperate better internally and become more environmentally effective. Up to this point different committees and departments of the municipality worked towards different goals and sometimes the goals could even be conflicting. Hence the internal work had to be more strictly governed and the goals had to be integrated and made common for the whole organisation of the municipality.

The mapping showed that the major environmental problem in Lidingö is the traffic situation. Other challenging sectors were energy savings in housing, recycling and sustainable consumption. Behavioural change through land-use planning is therefore at the core of the plan.

Links:

<http://www.lidingo.se/engelskasidor/startpagelidingostad/transportation/developmentandplanning.4.e865f5512573a29268800059.html>

2.4 Showcases / best practice - Transportation Supply/Demand Management

In this section the show cases and best practices regarding Transportation Supply/Demand Management are presented.

2.4.1 Green Parking Initiative (GPI)

Goal: Incentivize the use of low-emission cars through parking privileges.



Demand: Companies and local governments are asked to join the initiative and provision about 10% of their parking space.

Action: The idea of the green parking initiative is to provide free parking at parking hot spots with green-label (most eco-friendly) cars. Hot spots are: city

centres or near entrances of companies. Additionally, some of these parking places could be provided with (quick) charging facilities for electric vehicle's.

The city of Avignon, France, has introduced this kind of system in January 2011. The owner in SundayAfternoon, Instituut voor Duurzame Mobiliteit/Duurzaam op weg.

Cars with the lowest CO₂-emission in their category could apply for a badge with which they are allowed to use for free attractive parking places at highly attractive locations.

The administrative system behind these allowances is based on a CO₂-emission indexation of cars. It is the responsibility of companies and local authorities to create the special parking facilities at the most wanted locations.

In the Netherlands the CO₂-emission index of cars exists and at the moment is primarily used for a tax relieve system by the national administration, introduced in January 2010. Cars certificated as most-energy efficient in their category are A-labeled. A-label cars get 100% tax relieve on purchase and lower use-taxes. Sales reports for 2010 show an important increase in the purchase of smaller fuel-efficient cars.

The Green Parking Initiative stimulates local authorities and companies to create free parking places at hot spots for low-emission cars with an GPI badge and invites drivers to order the GPI badge. GPI provide some tools for authorities and companies to create and mark the green parking places, the distribution of badges and providing a GPI-locator for mobilists.

Results: GPI is one of the incentives to buy and use low-carbon cars. The isolated effect is hard to predict. GPI is a very transparent system, easy to communicate to the public and could be helpful to create public support to eco-friendly transport policies and a 'green' image of firms and local governments.

Lessons: The system is very easy to apply and doesn't require new research, complicated administrations or high costs. The operation could be cost-neutral to governments (costs could be covered from other the parking places.) The system could be introduced in the whole EU without complex regulatory and administrative complications.

There is one point of hesitation at the moment: there is lack of experience. An explanation for its slow adoption would be that the number of green cars is rather small; administrations and companies are not pushed to create green parking places yet. We expect this will change soon.

There is another important reason to create green parking facilities as soon as possible: they are very appropriate as charging facility for EV's. This also opens opportunities to invite electricity providers to participate in this initiative.

Note: low-emission cars (electric and hybrid vehicles) have already privileged access to historic city centers in Italy.

Links:

www.greenparkinginitiative.com

2.4.2 Sustainable Urban Mobility Plan for the Province of Huelva

In contrast to the aforementioned plans for the Emilio-Romagna Region and Stockholm/Lidingö, both of which have large populations in relatively dense centers with well-established public transport networks, here we present the Sustainable Urban Mobility Plan for the Province of Huelva. Whereas ERR took the approach of behaviour change, and Lidingö more the approach of Land Use, here we see primarily supply and demand, on the road to recovery from inefficient land use (sprawl); thus constituting the third of three major planning efforts which help to illustrate each of the major ITACA transport demand management categories.



The Province of Huelva, situated in the autonomous community of Andalusia, Spain, benefits from historic pedestrian scale developments in some areas, yet has not escaped the sprawl which has gripped Spain in the past two decades. Close to the sea and a destination for tourism, population growth has increased by only 1.5% while private vehicles increased by 12%.

Due to the increasingly negative impacts of motorized transport on quality of life, the environment, and the tourist industry, a joint effort to address transport problems in Huelva has led to Plan, which seeks to address a broad range of problems in concert across a broad area, tying together five local plans addressing in total, ten municipalities.

Getting a handle on the problem has been addressed systematically: first with data collection, including surveys, monitoring, measurements and identification of traffic patterns including goods movement; then with a *Mobility Diagnosis*, a mobility analysis including an environmental and energy inventory; finally with design proposals to establish measures to “promote or enhance the shift [to] modes of transport other than the private car.”

Each phase of the effort has benefited from the deliberate direction toward achieving sustainability goals. For example, surveys ask people not only about current behaviour, but what it would take to change that behaviour. As a result, a comprehensive and cross-cutting policy approach has emerged.

Examples of policies aimed at unifying and expanding the sustainability practices include new regulations and controls on parking in centers; new park and ride facilities to support transit and bicycle use; integration of disparate public transport systems; Improving urban freight logistics (loading, unloading, distribution, etc.); and providing comprehensive, quality infrastructure in support of bicycling and walking, including not only bike parking and urban infrastructure, but in some areas a bike share system and intercity linkages “so that all municipalities, and all the villages that form it, are linked together through safe and comfortable bike lanes.”

Energy efficiency is one of the key goals of the planning effort, with impressive projected results. Although undoing the land use is not as easy as using one key, the shackles of sprawl can be eased with wise and determined effort.

Results (projected):

For the Cycle Mobility Plan of Ayamonte, Isla Cristina and Lepe municipalities, it was “estimated that all these actions will reduce energy consumption and emissions figures by around 15%,”

The Sustainable Mobility Plan of Aljaraque, Cartaya, Punta Umbria and Gibraleón municipalities, focusing especially on matching transit service to peak periods, improving transit priority with bus lanes, and providing car sharing, along with bicycle infrastructure and a bike share system, is expected to “reduce energy consumption and pollutant emissions figures close to 18%.”

In Almonte, car dependency is a particular problem; by far the number one issue cited by residents was the need for more car parking (58%, next category 9%). The Sustainable Urban Mobility Plan of Almonte aims at improved parking management through pricing as a primary measure, combined with new public transport and new facilities for bicycling and walking including a new pedestrian plaza, and pedestrian paths linking schools. The Plan is projected to reduce energy consumption and pollutant emissions by up to 20% if successful.

In Rosal de la Frontera, reclaiming public space and quality of life from the automobile is paramount, as a regional route passes through the center of this small town, including a high volume of trucks heading to the Nerva’s hazardous waste landfill. Partly as a result, over 75% of trips made by car are under 1 km! To create an environment more friendly to walking and bicycling, a bypass is proposed to remove the heavy traffic from the center. Pedestrian facilities such as zebra crossings and plants are proposed, along with car sharing and a green path linking the town to a primary park destination which gets heavy traffic on weekends. With the Sustainable Urban Mobility Plan of Rosal de la Frontera, “it is expected that all these actions reduce at least 15% of motor transport harmful gas emissions in Rosal de la Frontera.”

The final area addressed is Almonaster la Real, comprised of a small town with 14 nearby villages and where “the use of private vehicles is almost 100% due to the absence of alternatives.” Through using school buses as public transit, and providing new teletaxi and car sharing, the plan expects to “reduce the dependence on single occupant private vehicles and enable the elderly population to move regularly safe and comfortable from the villages to Almonaster,” with “estimated energy savings and emissions by around 12%.”

The entire Executive Summary of the Sustainable Urban Mobility Plan for the Province of Huelva, including tables and maps, may be found in Annex I.

2.4.3 Bicycle paths in the Province of Rimini

Goal: Increase of cycling activity in Rimini.

Action: Started in 2008 and concluded in 2010.

In the last three years a new cycle way with exclusive right of way has been implemented in Via Marecchiese, a road connecting Rimini to Novafeltria. Other cycle paths have been implemented on the Via Montescudo, between Rimini and Montescudo and Rimini and Coriano. The total length of the path is around 12 km. Furthermore, a new path for bikes and pedestrian is in development stage along the banks of the river Conca, a well known naturalistic area.

Results: The following investments in cycle path have been made:

- S.P. Montescudo - Euro 1.297.000,00
- S.P.31 - Euro 1.000,00
- S.P. 258 Euro – Euro 2.477,500
- S.P.50 – Conca - Euro 135.000,00

Links:

<http://www.piste-ciclabili.com/forum/>

<http://www.piste-ciclabili.com/provincia-rimini>

http://www.provincia.rimini.it/progetti/mobilita/quaderni/q_07/quaderno/index.htm

2.4.4 Bike Sharing

Bicycle Sharing systems have been a goal for since many years. But they became attractive only recently as Information and Communication Technologies have applied to set up flexible bike sharing schemes. Smart cards allow bike-sharing subscribers to identify themselves, unlock a bike at a bike sharing station and bring it back and lock it at any other station in the city.

With the great success of the large scale Vélib system in Paris, such systems “went viral” spread around the globe, now in perhaps hundreds of cities. Research indicates that bike sharing has had significant effects. Bike sharing systems contributed to “creating a larger cycling population, increasing transit use, decreasing greenhouse gases, and improving public health” [16], all exciting and laudable outcomes. For example, Montreal’s Bixi claims to have saved over 1,500,000kg of greenhouse gases in a short time, and the Lyon bike share system found it had saved the equivalence of 9,300,000 pounds of CO₂ pollution from the atmosphere in just a few years.

Each implementation is different, from the hi-tech to the simple mechanical key; from the large scale to the small scale; from public access to private or special use access. These implementations have had varying rates of success.

ITACA partners have succeeded in Bike Share implementations as well, with results as follows.

2.4.4.1 Bike Sharing in Emilia-Romania: “C’entro in Bici” and “Mi muovo in Bici”

Goal: Promoting sustainable mobility, by reducing private car use.

Action: In Emilia-Romania’ cities there are two types of bike sharing systems:

- “C’entro in Bici” is unique in that, unlike many hi-tech implementations, it is based on a coded, non-duplicable physical key. The key is available free of charge by filling out a simple form with personal information. Once the user takes a bike from a public bike rack, the key can only be retrieved when the bike returned to the same storage place. In the case of non-delivery is possible to trace any abuse of this public service. This scheme is less flexible than chip-card based schemes, but it is simpler and less expensive to maintain, and in some ways more fail-safe.
- “Mi muovo in Bici” is a system based on smart cards.

Results: The “Mi muovo in Bici” system is currently located in three different cities and towns (Guastalla, Parma and Reggio-Emilia) with 29 bike sharing stations and a total capacity of 311 bikes and 173 bicycles. There are currently 2,890 subscription issued of which 1,584 are actively using the system.

The “C’entro in Bici” system is present in 23 different municipalities in Emilia Romania (see table below). It provides a total of 1424 bikes. In Italy, there are about 2,000 bike sharing stations of this type in 97 different cities. On national level there are over 65,000 subscribers.

“C’entro in Bici”: City and number of bikes	
Bologna	184
Bondeno	4
Carpi	40
Casalecchio	16
CastelMaggiore	20
Cesena	64
Correggio	12
Faenza	66
Ferrara	140
Imola	96
Lugo	16
Misano Adriatico	20
Modena	290
Piacenza	48
Polo ceramico (Sassuolo, Maranello, Formigine e Fiorano)	64
Ravenna	180
Regione Emilia-Romagna	28
Riccione	4
Rimini	100
S. Giovanni	20
Zola Predosa	12
Totale	1424

Table 2.3. Number of C’entro in Bici bikes by city

Links: <http://servizi.comune.fe.it/index.phtml?id=2228>

2.4.4.2 Public Transport Bike (OV Fiets)

Goal: Making train travel more attractive by offering cheap, automated, fast and easy-to-use rental bikes at Dutch railway stations.

Demand: Started in 2004 with 800 bikes on 70 locations with 11.000 subscribers it has grown to 200 locations with 4.500 bikes and 67.000 subscribers in 2009. Remarkably, without any marketing budget.

Action: The scheme has been invented and introduced by the Fietsersbond (an Netherland NGO for bicyclists) and ProRail, company responsible for building and maintaining the Dutch railway network. OV Fiets is an automated bike rental service, to which train travellers can subscribe. Subscription is cheap and the systems works with internet and an electronic id-pass, making it fast and easy to use.

Results: average, CO2-emissions for train travel are three times lower as car travel. A good product (fast, easy, affordable) like this bike sharing scheme does not need big promotion budgets, it taps in on an existing need. Stakeholder participation and involvement (Biker's association and others) delivers benefits and better quality.

Links:

<http://www.ov-fiets.nl/home>

2.4.5 CONCABUS (or “Valcona”):

Goal: increase public transport share, reduce CO2 emissions.

Demand: It is used very much by old people, students and occasional users.

Action: The Valle del Conca since 2008 has an on-demand transport service which allows people to book a bus few hours in advance to a defined parking place which is located closest to their homes. It is a kind of collective taxi with flexible timetable and non-prearranged stops as the TPL.

Results: Service started in 2008, it is still running successfully. It costs approximately 100.000 Euros the first year and 60.000 the following years. It saves an estimated of 72tonnes of CO2 if all bus trips were made by car.

Lessons: The successful CONCABUS scheme may be extended to other areas in the Province with similar characteristics.

Links:

http://www.provincia.rimini.it/progetti/mobilita/news/2009_02_09.htm

2.4.6 Mobility management in APEA: sustainable transport supply management at an Italian industrial site

The industrial area, which is located at a motorway exit near Cattolica (south of Rimini) has currently a high level of car use. For the site, also called Ecologically Equipped Productive Area (APEA) extensive studies and a survey have been carried out to assess the current situation of workers, land-use and transport offer [15], see also Annex I, APEA.

Goal: modal shift from car to bus and bike and reduction of CO2 emissions at the industrial site APEA of San Giovanni in Marignano. – Cattolica, Italy.

Action: The plan includes a mix of initiatives to increase the use of bus services, bikes, but also car-sharing, walking and inter-modal transport (combining train and bike). The study [15] concluded with a range of recommended measures which would be most suitable for this particular industrial area:

- “workers & school bus”: the idea is to combine a school bus service with a bus that brings workers into the industrial site. This bus would be an additional service and a complement to already existing bus services. The “workers & school bus” would be an attractive and efficient way to bring workers who have school children into the industrial site in the morning and back to their homes in the afternoon. Alternatively a “workers only” bus which would run once in the morning and afternoon has also been suggested. This workers bus would collect inscribed workers from their homes, just as a school-bus does with children
- Cycling network, including a link under the motorway exit to connect adjacent villages to the industrial site
- Pedestrian network, mainly within the industrial site
- Personal mobility trainer
- Bike sharing scheme
- Intermodal rail station (provide bike parking and bus service at rail station).

One part of the study is an attempt to quantify the effects of such measures taken, and in particular:

- How much would an improvement of a local bus service (“workers & school bus”) increase the public transport share?
- How much would the improvement of cycling network, bike sharing and bike and ride stations increase the bike share?

Results: The workers of the industrial site have been surveyed and asked for their current mobility habits and whether they would accept new, more sustainable transport options. From information about their current habits and their willingness to change, a new modal split could be determined for an improved public transport-scenario and an improved bike-scenario (see Annex I, APEA.). These are the results for the two scenarios:

Improved public transport-scenario: this scenario includes the present public transport and the additional “workers & school bus” service. It is assumed that they serve an area of up to 5km trip-length to the industrial cite. With this scenario, the estimated mode share for bus-services could be increased from currently 0.2% to 8%. This would result in an annual CO2 saving of be approximately 28t.

Improved bicycle scenario: if the local bike network were extended as proposed, the bike share could increase from currently 9.5% in the summer and 1.7% in the winter to 20% in the summer and 6.6% in the winter. The overall annual CO2 savings would be approximately 45t.

Links:

<http://www.provincia.rimini.it/progetti/mobilita/index.htm>

2.4.7 Monitoring of Regional Car-Sharing, Emilia-Romagna Region

Goal: The programme fosters collaboration between national, regional and local actors in promoting and providing car-sharing service as widely as possible.

Also: changing habits of drivers while creating a culture of good practices capable of mobility to determine positive and beneficial results in terms of improved quality of life for the whole community.

Demand: The usage of the Regional car sharing system can be quantified with 17,124 trips with per year, the total distance travelled has been 760,267 km or 113,580 hours of usage. The usage of the Regional car-sharing is slightly higher than the national average.

The car-sharing system has a widespread distribution of pick-up points, combined with an innovative computerized management system which avoids that users are obliged to return the car to the same pick-up point.

In Emilia Romagna a service, called ICS Car Sharing is available in Bologna, Modena, Parma and Rimini (Rimini service has ended in March 2009), offering a total of 75 “green” cars at 51 and pick-up points.

Results: Since the introduction of the car-sharing scheme in 2003, the service has been perceived as satisfactory by the customers, in major cities. The number of subscribers increased by 85% from 924 in 2003 to 1709 in 2009.

Other cities which have have joined the ICS scheme are: Bari, Bologna, Brescia, Catania, Florence, Genoa, Livorno, Mantova, Matera, Milan, Modena, Novara, Palermo, Padua, Parma, Perugia, Pescara, Reggio Emilia, Rome , Savona, Scandicci, Sesto Fiorentino, Taranto, Turin, Trieste, Venice, Viareggio. together with the provinces of Alessandria, Biella, Catania, Florence, Milan, Rimini, Bologna, Turin and Naples.

In Reggio Emilia, the car sharing service (non-adherent to ICS) has 102 registered users and offers 45 cars (and scooters). In one year the shared cars made 2009 trips and have been used for 744,000 hours. A particularity is the rental scheme includes over 300 electric pick-up trucks for an emission-free transport of services and goods.

Lessons: difficulties have been encountered in the absence of adequate governmental support from both, regions and local authorities. Support is necessary for maintaining a good level of service and for promoting car-sharing services as a way to combat pollution. Furthermore, the implementation of traffic restrictions which exclude car-sharing cars is an important tool to encourage car-sharing. It has been found that many users have subscribed to the service because they are allowed to enter the historic city center, which is otherwise not allowed for private cars. Thus clearly we see again the importance of complementary restrictions in concert with new supply, in order to facilitate changes in demand.

Links: <http://www.icscarsharing.it/main/>

2.4.8 Home-to-work Travel Plan (PSCL) for Hospital Campuses in Decentralised Areas of a Province; Ferrara, Emilia-Romagna Region

Goal: The general objective of the PSCL is to reduce the use, or at least the individual use, of private cars; in order to improve in positive terms for the whole community, the quality of life of the region from an environmental, social and economic viewpoint.

Action: Required over twelve years ago by the Ministry of the Environment, Guidelines have been developed including an action plan, for the assessment of current conditions, analysis for potential programmes and interventions, and ongoing monitoring. Focus groups were conducted.

Lessons: The document, included in Annex I, serves as a template for similar initiatives wherever a public body of hundreds of employees exists.

2.5 Conclusions and Recommendations

Management of transportation demand and fostering of behaviour change has impressive immediate potential. In theory, our collective approach to utilizing our vast transportation systems has the most promising potential for short-term rapid reductions in carbon emissions, as well as for gains in energy and resource savings, and a magnificent host of other co-benefits. Just as in the broader world of energy efficiency, where the first and biggest gain is from conservation and better use of existing resources, so it is in transportation.

If only those citizens who do already have a more sustainable alternative were to wake up tomorrow committed to taking conscious actions to best utilize the available options, major gains would be seen. Buses, trains, bike lanes and ride sharing could achieve a higher usage; efficient driving methods like trip chaining would be the norm; telecommuting and myriad other options would be used earnestly and ubiquitously. With society as leader, the longer-term changes such as supportive land use and improved transit provision would surely follow.

The numbers collected during the ITACA project speak clearly: 20% of traffic reduction in London and Stockholm through congestion charging; 20% of traffic reduction in Bologna centre by restricting access to residents, employees, public transport and delivery vehicles (Sec. 2.2.6); more than 50% reduction of traffic flow during peak hours in the Netherlands by paying a small incentive to people each time they avoid rush-hours (Sec. 2.2.5). Also changes on a smaller scale can make a difference: connecting an Italian industrial site near Cattolica to the surrounding villages by a bike path has the potential to double bike use (Sec. 2.4.6); the introduction of a local bus service to the same site may increase public transport share from virtually nothing to at least 8%.

The pace at which car traffic can be dropped in the various ITACA best practice cases is impressive (Sec. 2.2.). Monetary or legally enforced measures take effect practically overnight or in a few days. In any crisis, including those we may see due to climate change and energy scarcity, our practices can change overnight. We have discussed in the theoretical part (Sec. 2.1) that the acceptance for behavioural changes are more likely to happen during context changes. Clearly, crises are context changes, in which people reconsider their value system and may find solutions they believe are more appropriate and are better perceived by their social environment.

While we know of nothing else with such potential to instantly spread throughout the world as the powerful, cumulative effects of simple changes in behaviour, we have no magic wand with which to do so. Unfortunately, compared to other strategies such as patiently waiting for market penetration of new technologies – which may take decades and require vast new systems and new vehicles – fostering widespread behaviour change may be most promising. Yet in turn, it can seem perhaps the most difficult to achieve.

Of course the possibilities of certain demand management methods is bounded. There are limits to the potential of behavioural change through monetary incentives/disincentives, car-access restrictions and education/information: if a citizen can use sustainable alternatives only at a very high personal cost (in

terms of money, time or fatigue), he/she will not accept the alternative or even fight it. As for example, the congestion charges in London and Stockholm cannot be increased infinitely because it would be unacceptable for those who have truly no public transport alternatives. As discussed in Sec. 2.1.2., people are ready to change for a more environmentally friendly mode if its costs are acceptable compared to the present solution. For this reason, most ITACA mobility management schemes have included complementary measures, which can be classified in three categories:

- Ensure Equity
- Create sustainable alternatives
- Minimize environmental impacts (of cars)

Equity has been ensured by making exceptions for single persons or entire social groups with problems to access sustainable alternatives. One example is to exclude disabled from the congestion charging scheme (Stockholm Sec. 2.2.4) or to make exceptions to car-parking fees for both disabled and pregnant women (Emilia Romania Sec. 2.2.1).

Sustainable alternatives can often be created at low costs, using flexible and case specific solutions. New sustainable alternatives can be of organizational nature, additional transport supply or a change in land use. Here is a summary of concrete measures which have been indicated by ITACA partners:

- Car-sharing (Sec 2.4.7) or
- Car-pooling, is incentivised by offering free parking to employees who arrive with three or more passengers per car (Sec. 2.2.1).
- New transport supply which is tailored to a specific solution. Examples have been the “school&workers bus” at the APEA industrial site (Sec. 2.4.6); or adding more dedicated bike paths (Sec. 2.2.1) or improving the footpath network (Sec. 2.4.6).
- Reducing the need for travelling by offering closer alternatives. One example has been the construction of the canteen in the industrial area APEA (Sec. 2.3.1).

As to *minimize the environmental impacts of cars*, different incentives have been offered to use more low or zero emission vehicles. Such incentives can be of monetary nature or by granting access to the city centre (Bologna Sec 2.2.6) or to free parking (Green Parking Initiative Sec 2.4.1).

Demand management inevitably arrives at its limits, where the supply side of alternative transport must be increased substantially in order to absorb the massive modal shift from gasoline based individual transport. At this point technological solution must be available such as zero emission vehicles as well as user friendly public transport. However, for short distance (below 5km) the extension of foot paths and bicycle tracks should have a priority, in particular in times of restraint public spending.

Still, achieving major changes in transport behaviour can be problematic, in a society which values democratic principles, individual liberty, and freedom of choice; and where carbon-intensive travel is well established as the behavioural

and economic norm, with a resulting lower-density land use tending to lock-in dependence on private vehicles; it is a complex and compounded challenge to trigger a major shift to new models of behaviour.

Yet, again and again, it is found that many individuals actually prefer to live with more options, including the right and choice to live without relying on a car; that many in the culture are willing to change to achieve the critical goals of protecting our climate, and that they also value the associated co-benefits of reducing air pollution, reducing risk from traffic injury and fatality, and gaining the health benefits of a more active lifestyle which comes from use of transit, walking and bicycling. Individuals save in other ways as well, including precious time and even their own pocketbook, whether through saving on fuel with an electric vehicle, gaining a fiscal reward through a promotional programme, or saving even bigger by switching completely to the soft modes. There is also clearly an increasing market for alternative vehicles such as hybrids, plug-in hybrids and electric vehicles, as discussed in our Technology sections.

Simply providing better choices, and encouraging first steps toward new lifestyles, can begin the precipitation over time of a healthier and more robust economy, a new and more human-friendly land use mix, and ultimately a more sustainable society. In short: transformed cities and practices tomorrow, through behaviour changes today.

ITACA partners have tackled this challenge with gusto, as the diverse array of Management Model showcases illustrates. Some final remarks conclude the findings in each of the demand management categories.

2.5.1 Direct behaviour change

The potential for broad effects at the population level is again seen with behaviour change programmes.

Large scale programmes such as the Emilia-Romagna Mobility Plan and its related Sustainable Mobility initiative for Health Care Companies reaches tens of thousands of people, with significant effects. Large employers and institutions are thus ideal candidates to be trend setters and can influence subjective normative behaviour. They can mobilize their commuter base to shift behaviour and in the process supporting larger shifts of the entire community, both financially, culturally and through setting a good example.

Incentives work marvellously as individuals are constantly making transportation choices based on cost. Congestion pricing such as Stockholm's Congestion Tax (Sec. 2.2.4), and even *paying people not to drive during the peak* – as in the Spitsmijden system of financial rewards spreading across the Netherlands (Sec. 2.2.5) – have both worked very effectively in changing individual driver behaviours on a mass scale. Reductions of approximately 20% in total trips in Stockholm and 50% traffic flow reduction during peak hours with the Spitsmijden is a result to be achieved as soon as the schemes are introduced.

Likewise, providing discounted or free access to public transport, as done in many mobility plans (example Sec 2.2.1), gives boost to that mode share, and the ICT/CTS systems discussed in our Technology section likewise contribute to behaviour change by making transit easier to use and more transparent.

We have noticed cultural differences in the way incentives and disincentives are implemented: while in the Anglo-Saxon and Scandinavian part of Europe monetary penalties/incentives such as the congestion charge are well accepted, continental Europe prefers legal access restrictions, as for example for city centres. For example Stockholm implemented a similar congestion charge scheme than the one in London, but Paris failed to copy this system. However, also Edinburgh a congestion charge scheme got turned down. Apart from the previously mentioned equity problem of congestion charge, there are also a series of local issues to consider such as the level of internal traffic, public transport alternatives and practical implementation problems. For example in Stockholm it has been relatively simple to control the traffic across the main bridges. The acceptance of parking fees appear to be more accepted throughout Europe.

Sometimes small project can make a difference: The Pedibus allows kids to walk together as if they took the bus, and has spread to many schools in numerous cities in Italy (Sec. 2.2.3). Delivering children to school makes up a shockingly large portion of private automobile trips during peak hours, adding to pollution and congestion, whereas a healthier example is set if the children can walk or bicycle independently. But there is also a tangible long term effect: teaching children to walk and cycle to school increases their confidence to accomplished short distances in a sustainable way. This may have an influence on their parents choices as well as on their own future mobility.

Behaviour change requires both incentives and restrictions, or the proverbial “carrot and stick” to be most effective. The expansion of restricted traffic zones, pricing on peak travel, and traffic calming represent the “stick” whereas the options for convenient sustainable transport alternatives must be made available as discussed above.

The development of bicycle and pedestrian mobility, car-pooling and car sharing are, in this sense, systems that support the changing habits of drivers while creating a culture of good practices capable of mobility to determine positive and beneficial results in terms of improved quality of life for the whole community.

2.5.2 Supply and Demand Management

Demand can be changed with new supply. New supply can be as simple as a white stripe for a bicycle or a larger investment such as the provision of special parking privileges, and ideally charging stations, for the most eco-friendly cars, as seen with the Green Parking Initiative in the Netherlands (Sec. 2.4.1).

A tremendous untapped potential of new supply is the bicycle. Bicycles are an

incredible transportation tool, a real gem in the jewellery box of beautiful solutions: faster and more convenient than both the private automobile and transit for a large proportion of urban trips; emitting essentially zero carbon emissions, let alone other harmful air pollutants; and improving the health, happiness and physical longevity of its users. Bicycles require very little space compared to cars, and integrate brilliantly with public transport to greatly increase the population able to use transit without relying on a car. Thus the bicycle holds incredible promise and could provide overnight major gains, with but a change of behaviour. There is no more energy-efficient technology for individual land travel. This unrealized potential is easily demonstrated by viewing cities which have greatly increased their bicycle mode shares in only a generation, such as Amsterdam in the Netherlands and Copenhagen in Denmark.

There is no reason why we cannot see similar behaviour changes in other cities, particularly with the provision of appropriate facilities, and ease of access to bicycles. This is precisely the goal of the Rimini bicycle path project (Sec. 2.4.3). Likewise, the many Bike Sharing systems newly in place, such as our examples (Sec. 2.4.4), from Italy and the Netherlands, with tens of thousands of members, contribute increasingly to the shift to our most sustainable modes.

Although the first and foremost application of the bicycle for carbon reductions is in urban settings, in fact Europe has long-standing traditions in many rural areas, where bicycling can fulfil many travel needs and life tasks.

Ease of use of public transport. Transit has the highest short- to mid-term potential for reducing long trips by private automobile, given its ability to cover long distances. The longer the distance converted to transit from car travel, the greater the gains in reducing CO₂ emissions. New public transport infrastructure is regarded as a cost-intensive alternative. However, the “School & Workers bus” initiative (APEA industrial site, see Sec. 2.4.6) showed that with creative solutions it is possible to divert travel demand from car to public transport.

2.5.3 Land Use

In the longer term, sustainable land use is the ideal means of reducing not only private automobile distances, but all distances, making travel more efficient and suitable for soft modes like cycling and walking. For the long-term, land use is critical to reducing trip length and thus saving energy and preventing unnecessary carbon emissions.

When land-use policies are developed to a full extent we find carfree quarters that are linked with other parts of the city through public transport and cars are parked in the periphery. Such land use have been demonstrated to be the most effective and long lasting of all methods considered. The few carfree quarters in Europe showed the most dramatic drop in car-use (most businesses is done by bike and on foot) and car ownership dropped to 30% of households (Vauban, Freiburg, Germany) and more than half of the people who moved into the carfree quarter sold their car (see Sec. 2.1.3.3). Although there is an element of

self-selection here, there is clear indication of unmet demand for more such developments and such developments have clearly allowed at least those inclined to try, to reduce their car ownership and thus car use.

These examples demonstrate what can be achieved with Land-Use policies, but it remains a challenge to apply this experience to other European cities. It is believed that land use policies is frustratingly slow to take effect, and thus give the impression of being the slowest and least effective measures. This may help explain why so few examples are provided by ITACA partners. Another reason may be that the urban planning department and transport departments do insufficiently collaborate in order to find the best possible strategy.

Yet in fact, land use measures are fundamentally of utmost importance. Where in space things are located dictates where in terms of travel-time things are located and thus, how people travel.

If homes, jobs, schools, and commercial attractions are spread far apart from one another, many driving trips are instantly generated. Indeed, “the shortest distance between two points, is to move them closer together.”

Land use changes do not have to take generations. Relocating a single major attraction, as we saw in the APEA Canteen example (Sec. 2.3.1); or taking advantage of infill opportunities to increase the density and diversity of offerings locally, thus improving access by the environmentally friendly soft modes of walking, bicycling, and transit; can indeed change things quickly. Even more effectively, setting a long-term vision as described by the Stockholm Comprehensive Plan (see Sec. 2.3.2.) with its related Environmental Plan component, can fundamentally restructure the urban form, with lasting benefits.

2.6 Literature

[1] E. Cascetta; Transportation systems engineering: theory and methods. Kluwer Academic Publisher, Boston/Dordrecht/London, 2001.

[2] I. Ajzen; The Theory of Planned Behaviour, ORGANIZATIONAL BEHAVIOUR AND HUMAN DECISION PROCESSES 50, 179-211 (1991).

[3] A. Schlaffer, M. Hunecke, A. Dittich-Wesbuer, and H. Freudenaus; Bedeutung psychologischer und sozialer einussfaktoren fur eine nachhaltige verkehrsentwicklung.

Technical report, German Department for environmental protection and nuclear safety, Berlin, Germany, 2002. engl. The role of psychological and social factors in a sustainable transport development.

[4] S.G. Stradling; Travel Mode Choice, Porter, ISBN 978-0-12-381984-0.

[5] Sebastian Bamberg and Peter Schmidt; Regulating Transport: Behavioural Changes in the Field, Journal of Consumer Policy 22: 479–509, 1999. 2000 Kluwer Academic Publishers.

- [6] IFRESI-CNRS & Altermodal; Bike theft : impact and solutions, France, 2003, workshop at velo-city 2007.
- [7] R. C. Larson, K. Sasanuma; Urban Vehicle Congestion Pricing: A Review, *Journal of Industrial and Systems Engineering*, 2010, Vol. 3, No. 4, pp 227-242
- [8] Andre´ de Palma, Robin Lindsey; Modelling and evaluation of road pricing in Paris, *Transport Policy* 13 (2006) 115–126.
- [9] Congestion Impacts monitoring Fourth Annual Report, June 2006.
- [10] P. Timms; Transport models, philosophy and language, *Transportation* (2008) 35:395–410.
- [11] B. Verplanken, I. Walkera, A. Davisb, M. Jurasek; Context change and travel mode choice: Combining the habit discontinuity and self-activation hypotheses, *Journal of Environmental Psychology* 28 (2008) 121–127.
- [12] P. Newman, T. Beatley, and H. Boyer. *Resilient Cities: Responding to Peak Oil and Climate Change*. Island press, 2008. ISBN: 9781597264983.
- [13] P Newman, JR Kenworthy; Gasoline consumption and cities: a comparison of US cities with a global survey , *Journal of the American Planning Association*, 1989.
- [14] Emma Clarke, The evolution of Shared Space tec, Sept. 2006, p290-293.
- [15] Survey on the Mobility Home-Work in the Industrial Area of San Giovanni in The industrial area of San Giovanni in Marignano –Cattolica, Province of Rimini, Italy.
- [16] Paul DeMaio; Bike-sharing: History, Impacts, Models of Provision, and Future. *Journal of Public Transportation*, Vol. 12, No. 4, 2009.
- [17] Towards Carfree Cities conference series website. <http://worldcarfree.net/conference/>
- [18] Carfree.Com website. J. H. Crawford. <http://carfree.com/>
- [19] Carfree Cities. J.H. Crawford. 2002. International Books.
- [20] Carfree Design Manual. J.H. Crawford. 2009. International Books.
- [21] Transport Revolutions: Moving People and Freight Without Oil. Richard Gilbert and Anthony Perl. May 1, 2010. New Society Publishers. <http://transportrevolutions.info/>.

Chapter 3: Innovative Technologies

3.1 ITACA Innovative Technologies: Inventory and State of the Art.

As we saw in Chapter 2, transportation demand management is essential to the best use of technology, whether we address our existing technology and systems, or the introduction of new technologies. Behaviour change alone could in theory make a tremendous difference overnight. Technology too must change, but it is emphasized that to rely on new technology alone is to gamble with perilous risks. Can new propulsion technologies come online in time? What are the hidden costs? Are there unintended consequences?

Before we discuss the most promising new forms of propulsion in detail, it is important to step back and consider the optimal role of new technologies and their realistic use.

3.1.1 The City as Technology

The city is in fact *the largest installation of technology we create*, and thus its structure and operation has immense implications for energy use and all kinds of emissions.

Despite its ancient history, the city has changed much in a short span of mere generations to fit each new revolution in transport technology. First built for walking, then adjusted for horse and buggy, then heavily influenced by trains, trams and trolleys; even bicycles had an influence; and now in the petroleum era, the motorized vehicle has become the dominant organizing force. In the ITACA effort, we address the dire potential outcomes of that monumental – *and ongoing!* – investment in motorized mobility.

At this point in our history, we have the luxury of perspective and the potential of choice. We are more technologically advanced than ever, yet age-old urban solutions which reduce the need for motorized travel, and provide many co-benefits, may well attract our gaze.

It is now imperative that we create low-carbon economies, and the cities which support those economies; not only through new propulsion for vehicles, but through addressing our method of using the city, and the very structure of the city itself.

As we discuss new approaches to vehicles in this chapter, it is critical that we remain discerning, and measure our hope for a magical solution to the problem of carbon-emitting vehicle propulsion. Any new technology must be carefully analyzed, and ITACA partners have made an effort to present a good deal of that analysis here. We must be careful that we do not make the mistake of

merely exchanging one propulsion technology for another in a way that affords us only marginal gains, or worse. Just as in the case of renewable energy, the most effective first step to reducing our consumption is by definition conservation: to reduce the need for the technology in the first place.

Moreover, the energy and resources invested in a new propulsion system will surely be substantial, representing a massive new carbon expenditure even as we strive to reduce carbon emissions. Replacing today's global fleet of more than one billion combustion vehicles (and rapidly increasing), along with that global fleet's power sources, power distribution networks, and charging/fueling stations, is monumentally large in scale. The current system of petroleum distribution took a century to evolve, and we cannot expect an overnight conversion to a lower carbon propulsion system without serious costs along the way.

Thus if we are not very careful, the gains we achieve, viewed in a complete life-cycle analysis, may ultimately shave off only a fraction of overall emissions, and may do nothing to curb the ongoing growth of those reduced emissions. The larger system itself has costs as well which must be considered: for example, there are space and resource inefficiencies endemic to automobility: massive infrastructures for one, with costs which may not be sustainable in and of themselves over the long-term. Roads, bridges, garages, traffic signals, etc., are major infrastructure expenditures representing likewise major carbon emissions *simply for their construction, let alone their operation*, and represent a fiscal challenge for today's already straining public coffers.

Such large public works investments unfortunately do not last forever and must be continually maintained and replaced. If we perpetually increase their numbers, what will happen? How will we fare tomorrow?

Thus while some new technologies have great promise, it is important that we not limit ourselves by solely reinventing a new form of vehicle in the image of the current system. Rather, let us look holistically at where we have been, and where we can be, and choose the best combination in concert: a balance.

We arrived at the "car city" in a short time. With great leadership and wise choices, we must set a course so we can arrive at our next phase even more gracefully, without sacrificing accessibility as we transform mobility; and with a stronger, lower-carbon economy to show for it.

3.1.2 New Vehicle Propulsion Systems

Given the current reliance on private vehicles for both goods and people movement, at every level, from the local to the regional to the international, innovative new propulsion technologies and more eco-friendly new fuels to power such vehicles are key issues, and their promotion and deployment is thus a priority for future transport policies and strategies.

ITACA partners have combined our experiences in these areas, and our common conclusions are offered here as a tool to help both policy- and decision-makers choose their most suitable “best available technologies” in the short- to mid-term in fulfilling their quest for more sustainable, low-carbon transport. Each implementation is situation-specific, and we will see that the ITACA examples are no exception; the degree of development and implementation of new technologies is different in every region, as is the assessment and knowledge of those measures’ potential.

For this reason, our first step was to define the innovative technologies covered by the project, taking into account the work of the ITACA partners.

Given the available technologies for CO₂ saving, and using the definition of technology as “the practical application of knowledge especially in a particular area”, it is necessary to distinguish between new developments in vehicles versus those for fuels, although potential practical benefits will be obtained through a combination of both elements.

In a general way, the main innovative technologies useful for CO₂ emissions reduction in vehicles act over the propulsion system. Other helpful measures can also be adopted by the automakers, such as the use of new information systems, new designs, and light-weight materials.

The propulsion systems, or *powertrains*, available as alternatives to combustion for motor vehicles are as follows:

- Internal combustion engine vehicles (ICEVs)
- Hybrid electric vehicles (HEVs)
- Electric vehicles. Electric vehicles include pure battery-electric vehicles (BEVs), hybrid-electric configurations with fuel cells and batteries (FCEVs), and the most well established and most energy efficient form are grid-connected vehicles (GCVs) such as “on-wire” trains, trams and buses.

The costs and limited energy capacity of batteries are seen as the main stumbling blocks for a swift introduction of battery-electric vehicles. However, if the vehicle weight and travelling speeds are low and distances are short, then the energy consumption is lower and so are the size and the costs of the battery, giving a compounded benefit.

This is why there is a vivid development of small size battery-electric vehicles that are already available in some countries. These include Pedelecs (bikes with an electric motor as support), and battery-electric motorbikes. Micro-cars and mini-cars are another innovation in the same vein. These have short ranges, from 40km to 100km, and limited speeds, from 45km/h to 110km/h, and are thus quite viable for many urban trips. Electro-scooters with only 9-12kg of weight and electro-boards are available in some countries for a few hundred Euros. The latter is particularly attractive for young people without a driver’s license; moreover, they can be folded and brought in public transport as hand

luggage without disturbing other guests.

Despite the high potential of these devices for urban applications (most urban trips are short distance and low speed), too little attention has been paid to the whole range of E-mobility, much as too little value has been given to the bicycle which can also easily replace a large share of private automobile trips.

GCVs, being directly powered with no intermediary energy storage system, are the most environmentally friendly form of electric vehicle, but are primarily focused on fixed-route mass transport. While hypothetical innovations such as future trolleytruck networks or Personal Rapid Transit (PRT) solutions are important to consider, these types of electric transport are not discussed in detail in this *Handbook*, although ITACA partners have many successful case histories with electrified transport and aspire to increase their share. A key component to doing so is of course land use supportive of mass transport, which we discussed in Chapter 2. An excellent resource on the potential for the broad potential of future GCV uses is *Transport Revolutions: Moving People and Freight Without Oil*, by Richard Gilbert and Anthony Perl [21].

Thus there is a substantial range of possibilities in the world of electric mobility.

New information systems, in contrast, are mainly two-way communication systems either between the vehicle and the driver, or between the vehicle and the outside world (e.g., traffic signals, traffic management, public transportation management, emergency vehicles management, traveler information, advanced vehicle control and safety, commercial vehicle operations, electronic payment, railroad grade crossing safety, etc.).

Alternative fuels represent a third class of innovative transport technologies and include two main sources: fossil and renewable fuels, although it is also useful to consider blends of both.

Alternative fossil fuels used in urban and suburban vehicles are:

- Natural Gas
- Liquid Petroleum Gas (LPG)
- Electricity, used to charge batteries of battery-electric vehicles or to directly power GCVs. In this case there are no CO₂ emissions associated to the final use of the vehicle, but the actual CO₂ emissions produced from the average electricity generation mix, other efficiencies such as cogeneration (CHP) benefits, and systemic efficiencies such as line losses have to be taken into account as well. Of course there is a huge difference between different sources, as the same amount of electricity generated by burning coal will emit more CO₂ than that generated by nuclear and gas turbines, and more again than renewable energies (such as solar, wind, hydro, biogas and and geothermal).
- Hydrogen. Also in this case, there are no CO₂ emissions associated to the final use of the vehicle, but CO₂ emissions associated

to hydrogen production technology must be taken into consideration. Hydrogen can be produced from diverse domestic feedstocks using a variety of process technologies. Hydrogen-containing compounds such as fossil fuels, biomass or even water can be a source of hydrogen. Thermochemical processes can be used to produce hydrogen from biomass and from fossil fuels such as coal, natural gas and petroleum. Power from the grid or renewable and nuclear sources can be used to produce hydrogen via electrolysis. Gas natural reforming is the most usual way to produce hydrogen at present.

- Fuel blends of fossil and renewable liquid fuels, usually combination of gasoline and bioethanol or diesel and biodiesel in different percentages. Other blends, like hydrogen and methane, are being also tested to reduce CO₂ emissions.

Fuels from renewable sources used today are:

- Biofuels: bioethanol, biodiesel and biogas, considering in these cases the use of pure (100%) renewable fuel. This assumes that the methods used to generate the biofuels are sustainable.
- Electricity, as discussed above; considering in this case the power produced “*in situ*” from renewable energy and supplied to the vehicle through specific designed charging points, or using “green electricity” in conventional charging points, using valid sustainable energy certification schemes.
- Hydrogen, considering also in this case hydrogen produced from renewable energy, mainly via solar photovoltaic (PV) and wind power.

The following figure summarizes these technologies:

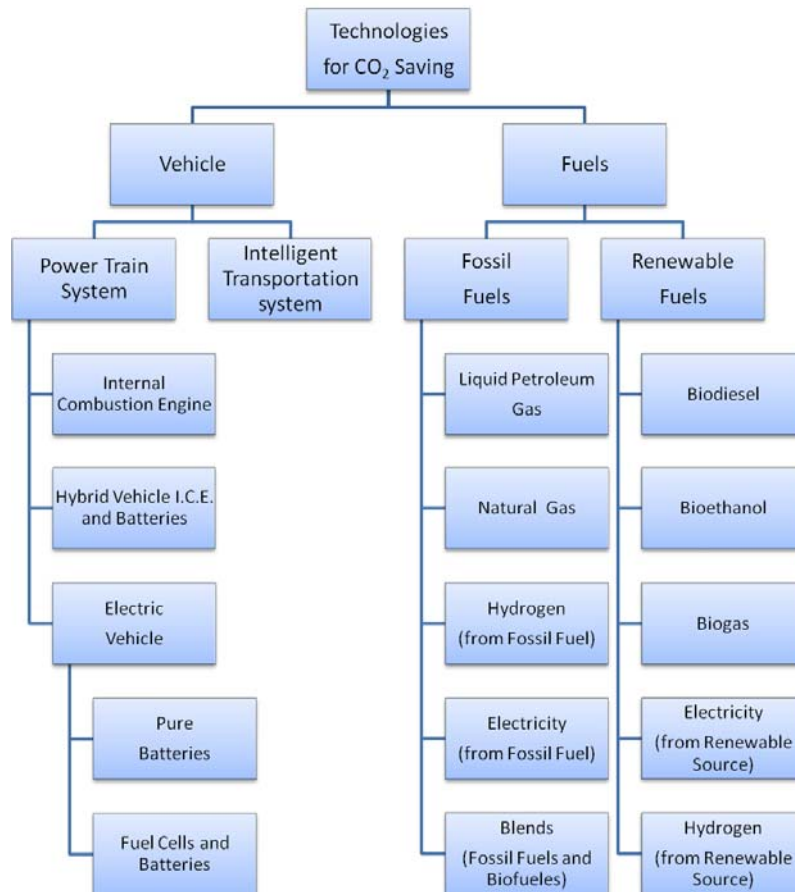

Figure 3.1 Summary of potential CO₂ saving technologies by type (vehicle and fuels)

A first selection about sustainable transport available technologies, potentially able to be evaluated, studied and compared with physically measurable parameters, is obtained from combining the above-mentioned technologies, then crossing propulsion system (powertrain) technologies with fuels in a matrix, in order to obtain practical configurations from the final user's point of view:

FUEL		POWERTRAIN SYSTEM	INTERNAL COMBUSTION ENGINE (ICEV)	HYBRID ELECTRIC VEHICLE (HEV)	FUEL CELL ELECTRIC VEHICLE (FCEV)	PURE BATTERY ELECTRIC VEHICLE (BEV)
FOSSIL FUELS	LPG		●			
	NATURAL GAS		●			
	HYDROGEN		●		●	
	ELECTRICITY			●		●
	FUEL BLENDS		●	●		
RENEWABLE FUELS	BIODIESEL		●			
	BIOETHANOL		●			
	BIOGAS		●			
	HYDROGEN		●		●	
	ELECTRICITY			●		●

Table 3.1 Matrix describing fuels compatible with powertrain systems

From this matrix of general configurations, ITACA partners decided to focus the project on the following technologies, in order of priority:

- Pure battery-electric vehicle (BEV).
- Hybrid-electric vehicle (HEV).
- Internal combustion engine with biogas and natural gas (BioGV/NGV), as well as blends hydrogen-methane.
- Fuel cell electric vehicle (FCEV).
- Intelligent transportation system (ITS).

Additionally, the choice of these technologies is supported by independent studies, communications and publications.

For example, the International Energy Agency (IEA) has recently published a report titled “Transport, Energy and CO₂: Moving toward Sustainability - How the world can achieve deep CO₂ reductions in transport by 2050” [1]. One of the main conclusions is that a revolution in transport technology will be needed to halve CO₂ emissions by 2050 and move toward a permanently lower greenhouse gas (GHG) future. This revolution must be built on some combination of electricity, biofuels, and hydrogen, barring major changes in travel behaviour. Both are needed.

While over the past decade most sectors managed to reduce their GHG emission levels, transport emissions experienced a continuous rise. By 2007, transport sector GHG emissions were 36% above their 1990 levels, meaning that transport was responsible for almost one quarter of the overall European GHG emissions (European Commission, 2010)[2].

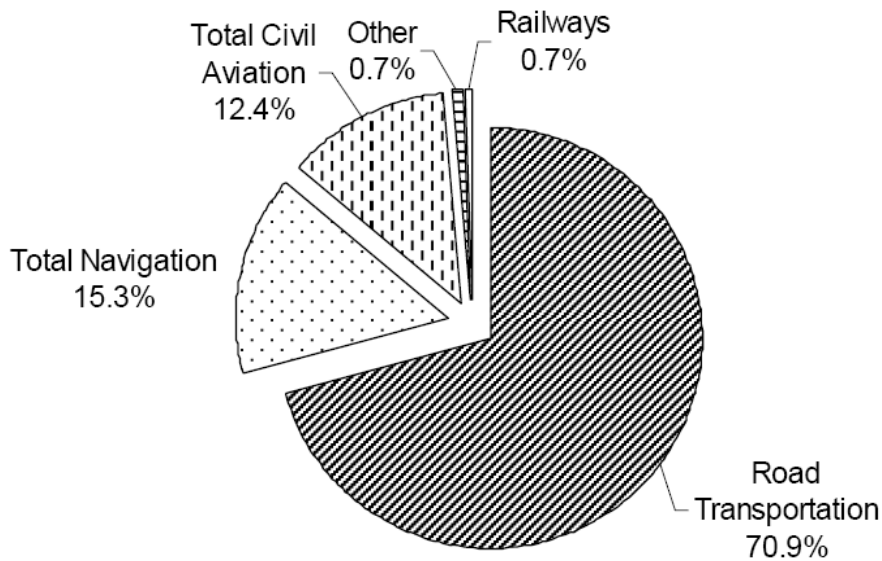

Figure 3.2 Distribution of GHG emission by transport mode in the EU- 27, 2007.
Source: European Commission

Researching and developing new technologies such as battery-electric or hydrogen-powered vehicles has therefore become a central challenge for European car manufacturers.

The Institute for Prospective Technological Studies (IPTS) of the Joint Research Centre of the European Commission has estimated that industry allocated around 13 billion Euros in R&D focusing on technologies to reduce GHG and air pollutant emissions in 2008 alone. This corresponds to 43% of their total R&D investments. Obtaining figures at this level of detail is difficult and thus largely based on expert assumptions and indirect indications; hence, the results are associated with significant uncertainties, but are dramatic nonetheless, illustrating the importance [3].

An overview of the results is provided in the following Table:

	Corporate R&D investment, EU-based companies (€m)	Public EU FP7 (€m, avg. per year)	Public MS R&D (€m)	Total R&D investment (€m)	Share of public
R&D in road vehicle technologies	31000	150	650	31800	2.5%
R&D in technologies for reducing GHG & air pollutant emissions	13400	n.a.	n.a.		
R&D in technologies for reducing GHG emissions	10000-11000	60	210	10270-11270	2.4-2.6%
Conventional engines	5000-6000	n.a.	80-125	5080-6125	ca. 2%
Electric vehicles (incl. hybrids)	1300-1600	20	60-100	1380-1720	5-8.5%
Fuel cells (& H ₂ production)	300-400 (100)	65 (15)	135 (45)	500-600 (160)	33-40%
Transport biofuels	ca. 270	55	65	390	31%

Table 3.2 R&D Investments in road vehicle technologies (2008), Rounded estimates. Source: IPTS

The International Energy Agency Hybrid & Electric Vehicle, in the 2009 Annual Report “Outlook for Hybrid and Electric Vehicles”, presented the status and forecast of the HEV market. In this context, the year 2008 showed a remarkable change in car sales [4]. The trend of increasing sales of larger and heavier cars, including sports utility vehicles (SUVs), was broken in favor of smaller and more energy-efficient cars. During the first half of 2008 the surging oil price was driving this change, while in the second half of the year the worldwide economic crisis had its impact. The economic crisis not only led to an increasing interest in smaller and more fuel-efficient cars, but it also caused a sharp decline in total vehicle sales. Remarkably, the share of hybrid-electric vehicles in total car sales continued to grow in many countries. This trend is expected to continue because of the following reasons:

- Hybrid-electric cars are more fuel-efficient than conventional cars, especially in urban traffic.
- More hybrid models will become available on the market.
- Higher production volumes may lead to lower hybrid vehicle costs and prices.
- Incentives for energy-efficient and low CO₂ emitting cars, such as low taxes.

The following figures illustrate the diversity of scenarios found in the literature on BEVs and PHEV respectively [5].

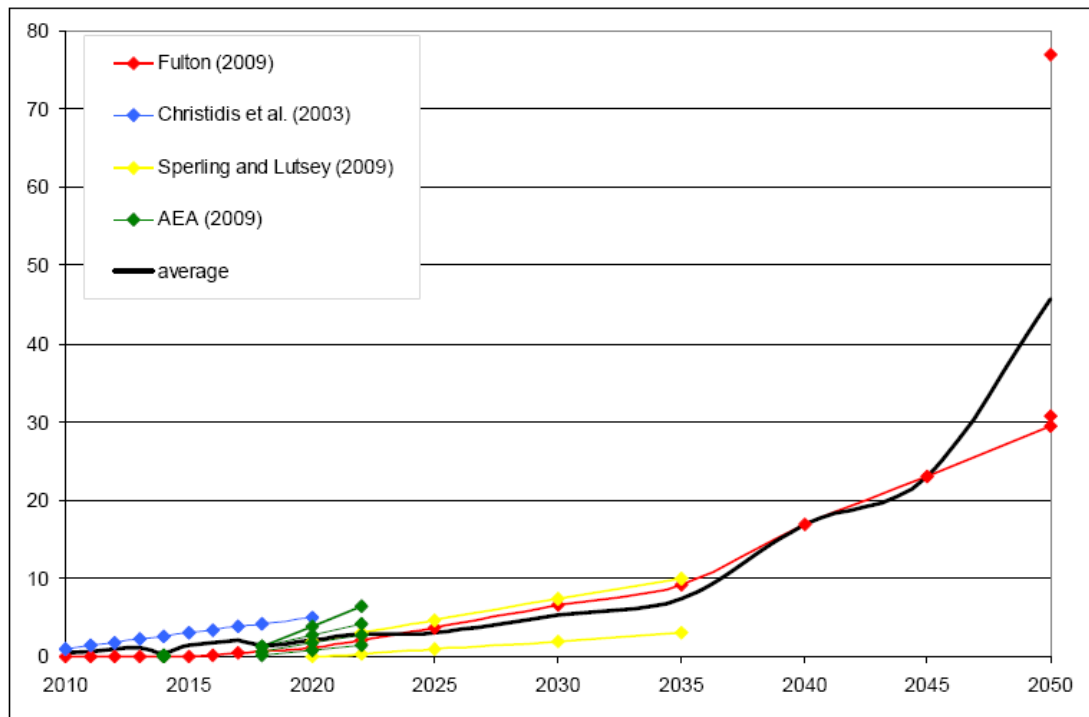

Figure 3.3 Scenarios about the percent market penetration of BEVs (share of new car registration) Source: JRC- IPTS

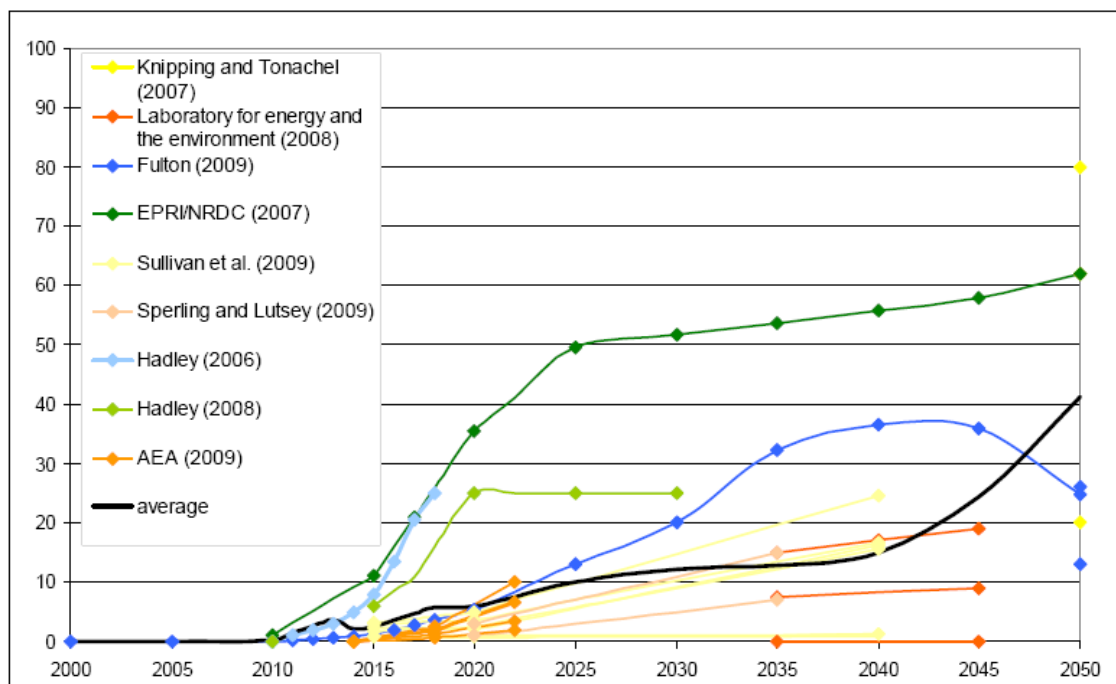

Figure 3.4 Scenarios about the percent market penetration of PHEVs (share of new car registration) Source: JRC- IPTS

Using HEV and BEV electric vehicles reduces CO₂ and pollutant emissions as compared to conventional vehicles, assuming the EVs are charged using low carbon electricity. Of course a life cycle analysis of the embedded energy and resources expended in each vehicle's production must also be conducted, to make a true comparison and be assured of the total benefit. However, dramatic urban health benefits begin to accrue immediately.

For example, hybrid goods distribution trucks and hybrid buses will have a positive effect on air quality in cities. However, for the time being the relatively small market penetration of hybrid and battery-electric vehicles limits their impact on the environment. Increased market share promises to increase the benefit.

Besides the powertrain solutions of hybridization, battery-electric vehicles, and biofuels, fuel cell cars are expected to be a means of reducing CO₂ emissions, again assuming they are powered from low-carbon and/or renewable sources. Certainly, other harmful pollutants from the vehicle are again prevented, which could reduce pollution in cities. When energy-efficient technologies are combined with low CO₂ fuels, these technologies become even more interesting.

With this in mind, some governments aim to achieve targets for EV market sales. Achieving 1 million EVs and PHEVs on the road by 2020 is the target in Germany. The Spanish government aims at the same amount (battery-electric and hybrid-electric vehicles) even sooner: by 2014. Table 2 gives the quantitative sales targets announced in some European countries.

Denmark	200 000
France	2 000 000
Germany	1 000 000
Ireland	350 000
Netherlands(1)	10 000
Spain(2)	1 000 000
Sweden	600 000
UK	1 550 000
Total	6 710 000

Table 3.3. Announced national EV sales targets for 2020 (except for Netherlands – 2015; and Spain – 2014) Taken from IEA, 2010. Source : JRC- IPTS

3.2 Real Operation Vehicle Database Analysis and Results

3.2.1 Configuration of database

The main purpose of the database is to provide a practical tool to assist decision makers to choose more sustainable transport system for a particular site.

Another objective of the database is to obtain actual values of emissions and energy consumption for each technology. Based on a global analysis has been done on standardizing the information available for demonstration projects.

The particular values of the projects are converted into common units for interpretation to obtain homogeneous comparison parameters. The database intends to offer, in an objective manner, an energy use and emissions assessment of a wide range of automotive fuels and powertrains relevant to Europe.

An accurate assessment of future fuel/propulsion system options requires a complete vehicle fuel-cycle analysis, commonly called a well-to-wheels (WTW) analysis. The WTW study analyzes energy use and emissions associated with fuel production (or well-to-tank [WTT]) activities and energy use and emissions associated with vehicle operation (or tank-to-wheels [TTW]) activities. Energy resources, such as petroleum, natural gas (NG), coal, and biomass, as well as the energy carrier, electricity, are considered as feedstocks to produce various transportation fuels, including gasoline, diesel fuel, hydrogen (H₂), ethanol (EtOH), compressed natural gas (CNG), methanol (MeOH), and Fischer-Tropsch (FT) diesel.

WTW analysis becomes necessary when comparing several vehicle technologies powered by different fuels.

The study is not a Life Cycle Analysis. It does not consider the energy or the emissions involved in building the facilities and the vehicles, or the end of life aspects. It concentrates on fuel production and vehicle use, which are the major contributors to lifetime energy use and GHG emissions.

The WTW study is the integration of emissions and energy consumption associated to the process Well to Tank with emissions and energy consumption in the process Tank to Wheel.

The Well to Tank (WTT) evaluation accounts for the energy expended and the associated GHG emitted in the steps required to deliver the finished fuel into the on-board tank of a vehicle.

The WTW study describes the process of production, transportation, manufacturing and distribution of selected fuel.

The Tank to Wheels (TTW) evaluation accounts for the energy expended and the associated GHG emitted by the vehicle/fuel combinations. The TTW study is contributed by the individual projects that have been incorporated into the database.

Due to the inclusion in the database of European and American projects, two different studies have been selected to determine WTT.

For European projects it has been selected the study "WELL-TO-WHEELS ANALYSIS OF FUTURE AUTOMOTIVE FUELS AND POWERTRAINS IN THE EUROPEAN CONTEXT" version 2C, march 2007 by EUCAR, CONCAWE and JRC (the Joint Research Centre of the EU Commission).

EUCAR, CONCAWE and JRC (the Joint Research Centre of the EU Commission) have updated their joint evaluation of the Well-to-Wheels energy use and greenhouse gas (GHG) emissions for a wide range of potential future fuel and powertrain options, first published in December 2003. This document reports on the second release of this study replacing version 2a published in December 2005. The original version 1b was published in December 2003. The methodology used to determine WTT is based on the description of individual processes, which are discreet steps in a total pathway, and thereby easily allows the addition of further combinations, should they be regarded as relevant.

For the American projects it has been selected the document "Well-to-Wheels Analysis of Advanced Fuel / Vehicle Systems - A North American Study of Energy Use, Greenhouse Gas Emissions, and Criteria Pollutant Emissions, by General Motors in 2005.

This study updates and supplements a previous (2001) North American study, conducted by GM and others (General Motors [GM] et al. 2001), of energy consumption and greenhouse gas (GHG) emissions associated with advanced vehicle/fuel systems (GM Phase 1 North American study). The primary purpose of this Phase 2 study is to address criteria pollutant emissions. Well-to-tank fuel economy and GHG emissions estimates were based on the same assumptions used in the 2001 study (GM et al. 2001)

The harmonization of the results is achieved with the study and calculation of emissions and energy consumption from the well to the wheel.

The information contained in the database is extracted from projects and studies, which have to provide a minimum of information to be included in the database:

- Studies and Project about real experience
- Number of vehicles involved in the project
- Technology used
- Power source of the fuel
- Economic fuel real data
- Emissions of CO₂ and other pollutants (NO_x, CO, THC, Particles, etc.) data

The main problem that the subgroup of technology innovation found was the lack of real experience-based projects that monitor fuel consumption and emissions. For such reason, some projects are based on estimates or bibliographic data to reference this consumption or emissions.

The database is completed with values calculated in real circuits of transport or commercial use of transport fleet.

The following projects are included in the database:

- Twelve-Month Evaluation of UPS Diesel Hybrid Electric Delivery Vans. (2009).

Project focuses on a parallel hybrid-electric diesel delivery van propulsion system currently being operated by United Parcel Service (UPS). This project is part of a series of evaluations from the U.S. Department of Energy (DOE).

Project discusses a 12-month evaluation of six model year (MY) 2007 Freightliner P70H hybrids that were placed in service in Phoenix, Arizona, during the second half of 2007. These hybrid vehicles are evaluated against six MY 2006 Freightliner P70D diesels during the first months of 2007. The diesel vans were chosen by using UPS's database and comparing the average miles per day of the six hybrids to that of diesel vans that had the same size and cargo capability and that were located at the two facilities. All fueling and maintenance data are collected by UPS from its databases and were shared with NREL for this evaluation.



Figure 3.5 Hybrid electric vehicle UPS. Source NREL

- FedEx Gasoline Hybrid Electric Delivery Truck Evaluation (2010)

The project FedEx presents results of a technology evaluation of gasoline hybrid electric parcel delivery trucks operated by FedEx Express in and around Los Angeles, California. FedEx Express is a large commercial fleet that operates more than 30,000 motorized vehicles and has hybrid electric (diesel and gasoline) vehicles currently in service. To carry out the project FedEx Express deployed gasoline hybrid electric vehicles (HEVs) on parcel delivery routes in the Sacramento and Los Angeles areas. The report presents the results of parcel delivery drive cycle data collection and analysis activities, 12-month in-use fuel economy and maintenance costs, and emissions and fuel

economy results of chassis dynamometer testing of a HEV and a comparative diesel truck at the National Renewable Energy Laboratory's (NREL's) Renewable Fuels and Lubricants (ReFUEL) laboratory. Six similar trucks were selected in-use evaluation project. Three of the trucks are HEVs, and three are conventional diesel trucks that serve as a control group. Comparison data were collected and analyzed for in-use fuel economy and fuel costs, maintenance costs, total operating costs, and vehicle uptime.



Figure 3.6 FedEx Express HEV. Source NREL

- CUTE. Clean Urban Transport for Europe

Between 2003 and 2005, twenty seven innovative, hydrogen-powered, fuel cell buses were built and placed in the public transport fleets of nine European cities, in seven different countries. At the same time original and leading edge hydrogen production, refuelling and support systems were also constructed. The buses were placed on normal public transport routes and data collected against a range of performance measures.



Figure 3.7 Fuel cell bus Oxford Circus, London. Source CUTE

- New York City Transit (NYCT) Hybrid and CNG Transit Buses (2006)

This report describes the evaluation results for new Orion VII low floor buses at NYCT with CNG propulsion (equipped with Detroit Diesel Corporation Series 50G CNG) and new hybrid propulsion (equipped with BAE Systems' HybriDrive propulsion system). The final results represent a 12-month evaluation of these two groups of buses. In this project was evaluated 10 CNG Orion VII buses (model year 2002) selected at random from the West Farms Depot, and 10 hybrid Orion VII buses (model year 2002) chosen at random from the Mother Clara Hale Depot. This evaluation of the Orion VII CNG and hybrid buses compares buses that are the same age and the same bus platform. DOE/NREL evaluated prototype diesel-hybrid and CNG buses.

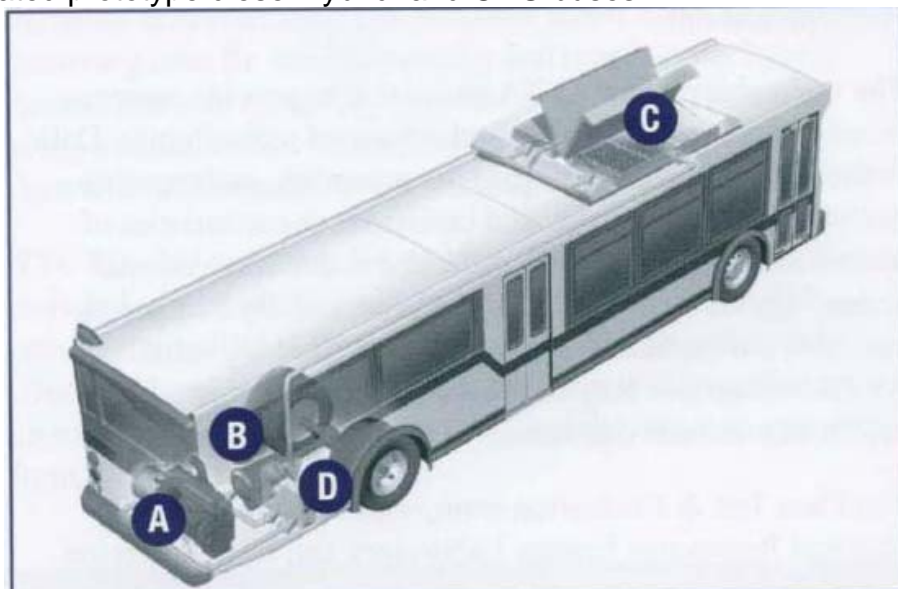

Figure 3.8 BAE Systems HybriDrive Propulsion System. Source NREL

A: A 5.9-liter diesel engine runs at an optimal controlled speed and is connected to a generator to produce electrical power for the drive motor and batteries.

B: The electric motor drives the vehicle and acts as a generator to capture energy during braking.

C: The batteries supply power during acceleration and hill climbing and store energy recovered during regenerative braking.

D: The propulsion control system manages the entire system and optimizes performance for emissions, fuel economy, and power.

- Zero Regio. Demonstration of Fuel Cell Vehicles & Hydrogen Infrastructure

Zero Regio aimed at developing and demonstrating zero-emission transport systems in European cities based on hydrogen as an alternative motor fuel. Project was developed in Frankfurt (Germany) and Mantova (Italy).

Vehicles and the infrastructure were operated in real-life urban conditions over a period of three years. Operational data acquired on vehicles and infrastructure was analyzed and evaluated with respect to energy efficiency and environmental.



Figure 3.9 Mercedes - Benz A-Class FCell and FC Panda. Source: Zero Regio project

- TUSSAM. Follow-up study of battery-electric minibuses

A project with battery-electric minibuses was developed in Seville. The project was developed in two phases: an experimental phase in which two of these vehicles joined the fleet in April 2007 and a second phase, in which two other vehicles were acquired in September 2008. The battery-electric minibuses have a capacity for 27 passengers made the route of line 5 that runs through the historic center of Seville, avoiding in this way, the harmful pollution from internal combustion vehicles in the historical center.



Figure 3.10. Mini E: Oxford, Los Angeles, Berlin, New York, Munich

Mini E is a battery-electric car experience developed by BMW. This is a restructuring of the classic Mini Cooper in a BEV. Mini E Project is developing in several countries including the United States, Germany and UK. The first trial was launched in the U.S. in June 2009 and the Mini E was available through leasing to private users in Los Angeles and New York and then the second trial was launched in UK and Germany. This project has over 500 BEV for private use. The test of emission and fuel economic has been conducted by U.S. Department of Energy Advanced Vehicle and Oxford Brookes University.



Figure 3.11 Mini E. Source Washington Auto Show

- Barcelona Public Transport : biodiesel, CNG, hydrogen and hybrid

The public transport company carried out a comparative study between different vehicle technologies belonging to the urban transport fleet. For the experience, the database of the company was used with emission measurements and fuel consumption of vehicles on the roads daily. In this study were compared hybrid buses, buses with biodiesel and CNG buses. The study included CUTE project experience with Fuel Cell Bus.



Figure 3.12 Bus of TMB Barcelona. Source TMB

The content of the sheets constituents of the database will be briefly discussed below.

The database was developed using Microsoft Excel. The database contains at present six sets of data, providing technological information and the location which the project has been developed.

The first set of data are described in the sheet is called "*Project and City*", and it collects information about the project scope, duration and start date. It is important to highlight the information about the characteristics of the city where the project is developed.

The following sheet is named "*Climatology and physical characteristics*", and it compiles the climatological information from the city where the project is developed, as well as other data related with the physical characteristics of the city.

The sheet "*Technology*" compiles information concerning the technical characteristics of the vehicle.

The section about "*Fuel and cost*" includes data concerning the fuel used and the calculations for determining the necessary parameters such as fuel economy and expected range. Additionally, some data concerning the acquisition or operational costs are included when available.

In the following sheet, "*Emissions*", it is conducted the WTW study for CO₂ emissions for the considered cases. Also the TTW emissions of most common pollutants emitted by vehicles are detailed.

The last sheet is named "*Energy consumption*", and it presents the WTW study of energy consumption used in every project.

3.2.2 Project and city

The group of data called "Project and City" consists of the following fields:

Regarding the project:

- Name
- Start date
- End date
- Scope.

Regarding to the city:

- Name
- Region
- Country
- Population
- Metropolitan area
- Main activities.

The section concerning the project includes all general information about the project and the year of commencement and completion of the project. It is important to use projects carried out in recent years to get actual results. As an exception, it has been included the CUTE project, ended in 2005. The CUTE project was developed in 9 European cities with a technology as new today as fuel cells applied to urban transport.

This section includes the scope of the project. There are a wide variety of studies ranging from the local area such as the "ELECTRIC BUS EVALUATION IN SEVILLE" to international projects as the project "MINI E".

The section concerning the city provides general information about the cities where the project has been developed such as population, the existence of the metropolitan area and the main activity that takes place in the city.

In the section on "population", the number of people living in the city is specified. Through this search for information, the existence of metropolitan area has been verified in the various cities

These data have been extracted from various official websites of each city and country where projects have been developed.

Section "Main activities" is classified in the following activities:

- Commercial
- University
- Administrative center
- Historical center.

The type of the commercial activity of the city influences the driving of vehicles directly. The number of accelerations, stop, average speed and maximum speed restrictions affect fuel consumption and therefore the final emissions. This is important in order to decide which technology is most appropriate for a given site.

Projects UPS and FedEx have 3 items for hybrid vehicles and 3 for diesel vehicles. The values of fuel consumption and emissions were calculated with three different driving cycles simulated in official laboratories. With these tests, the fuel consumption values calculated experimentally were corroborated by monitoring vehicles for everyday use.

The FedEx project selected the appropriate chassis dynamometer test cycles, calculated kinetic intensity, was used to compare real, collected drive cycle data to industry drive cycles. Kinetic intensity is a calculated “macro-characteristic” that represents the transient intensity (accelerations and decelerations) of a particular drive cycle. Based upon the observed drive cycle kinetic intensities, the Orange County Bus cycle (OC Bus) was selected as a cycle that best approximated the average of the routes driven by the initial three routes. The New York City Cycle (NYCC) and HTUF4 cycles were selected as upper and lower boundaries for kinetic intensity.

For the UPS project the tests were conducted over three driving cycles: the Combined International Local and Commuter Cycle (CILCC), the West Virginia University City (WVU City) cycle, and the Central Business District (CBD) cycle. Vehicle exhaust emissions and fuel consumption were measured.

For all other projects, a search of information on different official web pages has been done in order to assign that the economic activity is the closest to each one of the cities where the projects are developed.

There are cities where confluence various economic activities, such as Seville. In this case, "Historic Center" has been chosen because it is the route that travels the battery-electrical Minibus project.

Three quarters of the data entered in the database originate in projects developed in Europe.

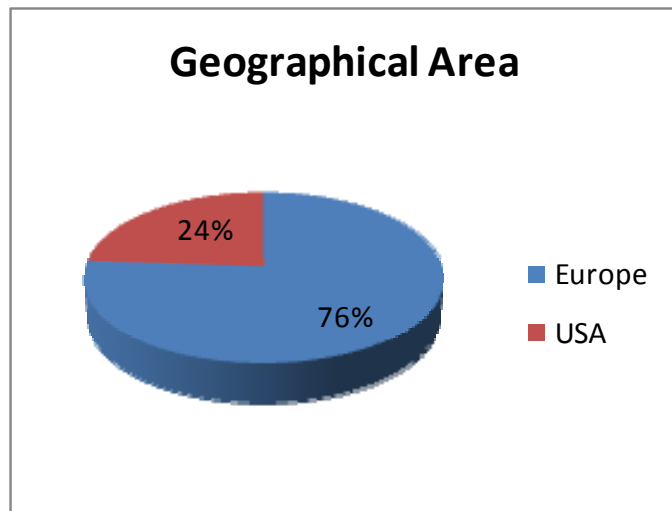

Figure 3.13 Source of Project

The database collects information of the projects carried out in three states of USA and in 8 EU countries involving a wide range of countries. This variety of countries enrich the database by providing information both geographical, that develops in the sheet "*climatology and physical characteristics*", and different energy sources of fuel used that will affect the WTW analysis performed.

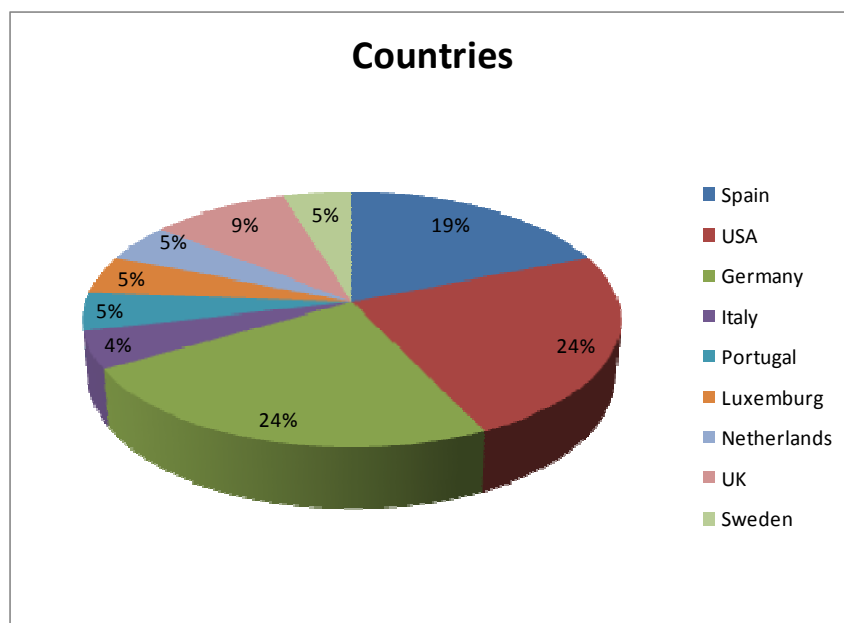

Figure 3.14 Percentage contribution of each country to the database

In order to compare experiences and to decide which technology is most appropriate for a given site, it is useful to compare the number of inhabitants. The population of the city gives information about the extent and if there is metropolitan area. The database contain numbers of inhabitants in the city center and in the event of exist metropolitan area, the approximate value of the population has been added. Also discusses the main activity of the city that is a direct factor of the intensity of transport.

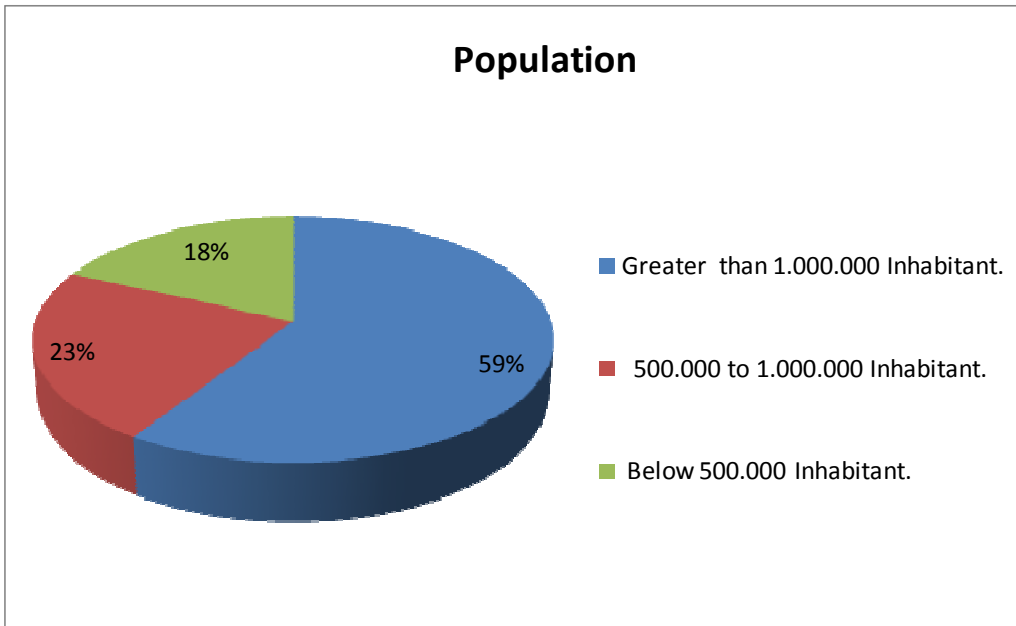

Figure 3.15 Types of city by population

c

Project				City						
Name	Start date	End date	Scope	Name	Region	Country	Population	Metropolitan Area	Population M.A.	Main activities
UPS	2007	2008	Regional	Phoenix	Arizona	USA	1.445.632	Yes	4.192.887	Commercial
UPS	2007	2008	Regional	Phoenix	Arizona	USA	1.445.632	Yes	4.192.887	University
UPS	2007	2008	Regional	Phoenix	Arizona	USA	1.445.632	Yes	4.192.887	Administrative center
UPS	2007	2008	Regional	Phoenix	Arizona	USA	1.445.632	Yes	4.192.887	Commercial
UPS	2007	2008	Regional	Phoenix	Arizona	USA	1.445.632	Yes	4.192.887	University
UPS	2007	2008	Regional	Phoenix	Arizona	USA	1.445.632	Yes	4.192.887	Administrative center
FedEx	2009	2009	Regional	Los Angeles	California	USA	3.792.621	Yes	17.800.000	Commercial
FedEx	2009	2009	Regional	Los Angeles	California	USA	3.792.621	Yes	17.800.000	Commercial
FedEx	2009	2009	Regional	Los Angeles	California	USA	3.792.621	Yes	17.800.000	Commercial
FedEx	2009	2009	Regional	Los Angeles	California	USA	3.792.621	Yes	17.800.000	Commercial
FedEx	2009	2009	Regional	Los Angeles	California	USA	3.792.621	Yes	17.800.000	Commercial
FedEx	2009	2009	Regional	Los Angeles	California	USA	3.792.621	Yes	17.800.000	Commercial
CUTE STOCKHOLM	2003	2005	European	Stockholm	Uppland	Sweden	847.073	Yes	1.400.000	Administrative center
CUTE MADRID	2003	2005	European	Madrid	Madrid	Spain	3.284.110	Yes	6.043.031	Administrative center
CUTE LONDON	2003	2005	European	London	London	United Kingdom	8.278.251	Yes	12.000.000	Administrative center
CUTE STUTTGART	2003	2005	European	Stuttgart	Baden-Württemberg	Germany	600.038	Yes	5.300.000	Administrative center
CUTE AMSTERDAM	2003	2005	European	Amsterdam	North Holland	Netherlands	1.209.419	Yes	2.158.592	Administrative center
CUTE BARCELONA	2003	2005	European	Barcelona	Cataluña	Spain	1.621.537	Yes	5.012.961	Administrative center
CUTE HAMBURG	2003	2005	European	Hamburg	Hamburg	Germany	1.751.656	Yes	2.550.000	Commercial
CUTE LUXEMBOURG	2003	2005	European	Luxembourg	Luxembourg	Luxembourg	76.420	Yes	103.973	Administrative center
CUTE PORTO	2004	2005	European	Porto	Porto	Portugal	1.100.000	Yes	1.300.000	Commercial
NEW YORK CITY TRANSIT	2004	2005	Regional	New York	New York	USA	8.400.000	Yes	18.900.000	Administrative center
NEW YORK CITY TRANSIT	2005	2005	Regional	New York	New York	USA	8.400.000	Yes	18.900.000	Administrative center
NEW YORK CITY TRANSIT	2005	2005	Regional	New York	New York	USA	8.400.000	Yes	18.900.000	Administrative center
ELECTRIC BUS EVALUATION IN SEVILLE	2007	2008	Local	Seville	Andalucía	Spain	703.206	Yes	1.508.605	Historical center
ELECTRIC BUS EVALUATION IN SEVILLE (AC)	2007	2008	Local	Seville	Andalucía	Spain	703.206	Yes	1.508.605	Historical center
ELECTRIC BUS EVALUATION IN SEVILLE	2007	2008	Local	Seville	Andalucía	Spain	703.206	Yes	1.508.605	Historical center
ZERO REGIO GERMANY	2008	2009	European	Höchst, Frankfurt	Hesse	Germany	700.000	No	700.000	Historical center
ZERO REGIO GERMANY	2008	2009	European	Höchst, Frankfurt	Hesse	Germany	700.000	No	700.000	Historical center
ZERO REGIO ITALY	2007	2009	European	Mantova	Lombardy	Italy	48.400	No	48.400	Commercial
ZERO REGIO ITALY	2007	2009	European	Mantova	Lombardy	Italy	48.400	No	48.400	Commercial
EMT BARCELONA	2007	2009	Local	Barcelona	Cataluña	Spain	1.621.537	Yes	5.012.961	Administrative center
EMT BARCELONA	2007	2009	Local	Barcelona	Cataluña	Spain	1.621.537	Yes	5.012.961	Administrative center
EMT BARCELONA	2007	2009	Local	Barcelona	Cataluña	Spain	1.621.537	Yes	5.012.961	Administrative center
Mini E UNITED KINGDOM	2010	2011	International	Oxford	South East England	U.K.	145.100	No	145.100	University
Mini E LOS ANGELES	2010	2011	International	Los Angeles	California	USA	3.792.621	Yes	17.800.000	Commercial
Mini E NEW YORK	2010	2011	International	New York	New York	USA	8.400.000	Yes	18.900.000	Administrative center
Mini E BERLIN	2010	2011	International	Berlin	Berlin	Germany	3.450.000	Yes	4.400.000	Administrative center
Mini E MUNICH	2010	2011	International	Munich	Bavaria	Germany	1.326.807	Yes	2.500.000	Administrative center

Figure 3.16 Project and city sheet

3.2.3 Climatology and physical characteristics

The sheet "*Climatology and physical characteristics*" contains all the information referred to climatological conditions in each of the cities where the project is developed and the group of data consists of the following fields:

- Relief
- Maximum temperature
- Minimum temperature
- Average summer temperature
- Average winter temperature
- Precipitation.

The first parameter included in the sheet is the relief. This parameter ranks cities according to the difference in height between the maximum and minimum in the city. The criterion used is *Low* for difference in elevation from 0 to 50 m, *Medium* for differences between 50 and 150 m and *High* for the difference in elevation above 150 m. This parameter influences directly on the fuel consumption and emissions. An example is shown in fuel consumption difference between the two cities as Barcelona, with a high relief, and Amsterdam with a low relief. There is a difference of 1.27 times the consumption of hydrogen between a FCEV in Barcelona and a FCEV in Amsterdam. This increased fuel consumption has a direct impact on emissions of CO₂. FCEV technology refers to CO₂ emissions as well to tank due to TTW emissions are zero.

This set of data shows also the values of temperatures and precipitation. It lists the maximum and minimum temperature values recorded in each of the cities, and the average values in the summer and winter months. These values can directly affect the performance of some technologies such as the fuel cells and batteries.

These climatological data can characterize the city and determine which of the cities featured in the database looks like a possible site of study.

Project	Climatology and physical characteristics					
	Name	Relief	Max. Temperature (°C)	Min. Temperature (°C)	Avg. Temp. (summer) (°C)	Avg. Temp. (winter) (°C)
UPS	Medium	50	-8,9	24,77	9,86	194,6
UPS	Medium	50	-8,9	24,77	9,86	194,6
UPS	Medium	50	-8,9	24,77	9,86	194,6
UPS	Medium	50	-8,9	24,77	9,86	194,6
UPS	Medium	50	-8,9	24,77	9,86	194,6
UPS	Medium	50	-8,9	24,77	9,86	194,6
FedEx	Medium	45	-2,2	20,4	14,1	305,3
FedEx	Medium	45	-2,2	20,4	14,1	305,3
FedEx	Medium	45	-2,2	20,4	14,1	305,3
FedEx	Medium	45	-2,2	20,4	14,1	305,3
FedEx	Medium	45	-2,2	20,4	14,1	305,3
FedEx	Medium	45	-2,2	20,4	14,1	305,3
CUTE STOCKHOLM	Medium	34,4	-27	17,5	-3	539
CUTE MADRID	Medium	40	-10,1	24	9,8	436
CUTE LONDON	Low	38,4	-18,8	18	4	583
CUTE STUTTGART	High	37,7	-21,2	16,25	-3	689
CUTE AMSTERDAM	Low	36,8	-24	15,6	3,3	760
CUTE BARCELONA	High	37,4	-16,2	21,9	11,3	640
CUTE HAMBURG	Low	38,5	-29,1	21	-1	746
CUTE LUXEMBOURG	High	37,9	-23,1	16,5	2,3	760
CUTE PORTO	Medium	40,1	-5	19	9,75	1267
NEW YORK CITY TRANSIT	Medium	41,7	-26,1	22,7	2,9	1056
NEW YORK CITY TRANSIT	Medium	41,7	-26,1	22,7	2,9	1056
NEW YORK CITY TRANSIT	Medium	41,7	-26,1	22,7	2,9	1056
ELECTRIC BUS EVALUATION IN SEVILLE	Low	47	-4	35,3	5,2	550
ELECTRIC BUS EVALUATION IN SEVILLE (AC)	Low	47	-4	35,3	5,2	550
ELECTRIC BUS EVALUATION IN SEVILLE	Low	47	-4	35,3	5,2	550
ZERO REGIO GERMANY	Medium	38,7	-23,8	17,3	5,5	620,7
ZERO REGIO GERMANY	Medium	38,7	-23,8	17,3	5,5	620,7
ZERO REGIO ITALY	Medium	39,4	-5,8	21,3	4,8	822
ZERO REGIO ITALY	Medium	39,4	-5,8	21,3	4,8	822
EMT BARCELONA	Medium	37,4	-16,2	21,9	11,3	640
EMT BARCELONA	Medium	37,4	-16,2	21,9	11,3	640
EMT BARCELONA	Medium	37,4	-16,2	21,9	11,3	640
Mini E UNITED KINGDOM	Low	34,9	-20,8	16	5,7	642,1
Mini E LOS ANGELES	High	45	-2,2	20,4	14,1	305,3
Mini E NEW YORK	Medium	41,7	-26,1	22,7	2,9	1056
Mini E BERLIN	Low	38,1	-26,1	17,4	2,2	570,7
Mini E MUNICH	Low	37,1	-31,6	15,6	-0,4	967,4

Figure 3.17 Climatology and physical characteristics sheet

3.2.4 Technology

This section of the database compiles specific information referring to the technology used in each of the projects.

The group of data called "Technology" consists of the following fields:

- Type of technology
- Type of vehicle
- Number of vehicles
- Manufacturer
- Model
- Power
- Use of vehicle
- Kilometers.

One of the main obstacles for the realization of the database has been finding real operational data in experiences and projects, i.e., when fuel consumption and emissions during the development of the usual activity of the vehicle is measured.

These measurements were made by monitoring vehicles with GPS tracking of routes and contrasting values measured with laboratory tests on chassis dynamometer.

21 experiences encompassed in 8 projects have been documented.

The technologies considered in the project are:

- Hybrid electric vehicles (HEV) 8 items.40 vehicles.
- Internal combustion engine (ICE) 10 items, 8 items ICE with diesel and 2 items ICE with gasoline. 699 vehicles.
- Fuel cell electric vehicle (FCEV) 11 items .35 vehicles.
- Internal combustion engine with natural gas (ICENG) 2 items. 10 vehicles.
- Batteries electric vehicle (BEV) 7items. 638 vehicles.
- Internal combustion engine with biodiesel (Biodiesel) 1 item.124 vehicles.

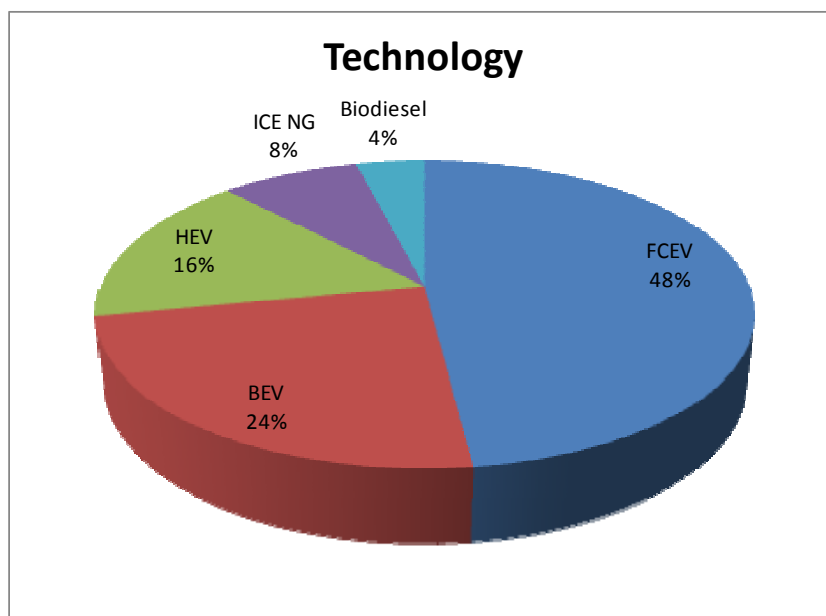

Figure 3.18 Share of different technologies

The different types of vehicles that make up the projects have been classified according to directive 2007/46 CE.

- Category M: Motor vehicles with at least four wheels designed and constructed to transport passengers.
- Category M1: Vehicles of eight seats or less (excluding the driver) designed and manufactured for passenger transport.
- Category M2: Vehicles with more than eight seats (excluding the driver) with a maximum mass not exceeding 5 tons, designed and constructed for the carriage of passengers.
- Category M3: Vehicles with more than eight seats (excluding the driver) with a maximum mass exceeding 5 tons, designed and constructed for the carriage of passengers.
- Category N: Motor vehicles with at least four wheels designed and constructed to transport goods.
- Category N1: Vehicles with a maximum mass exceeding 3.5 ton designed and constructed for the carriage of goods.
- Category N2: Vehicles with a maximum mass exceeding 3.5 ton but not exceeding 12 ton designed and constructed for the carriage of goods.
- Category N3: Vehicles with a maximum mass exceeding 12 ton designed and constructed for the carriage of goods.

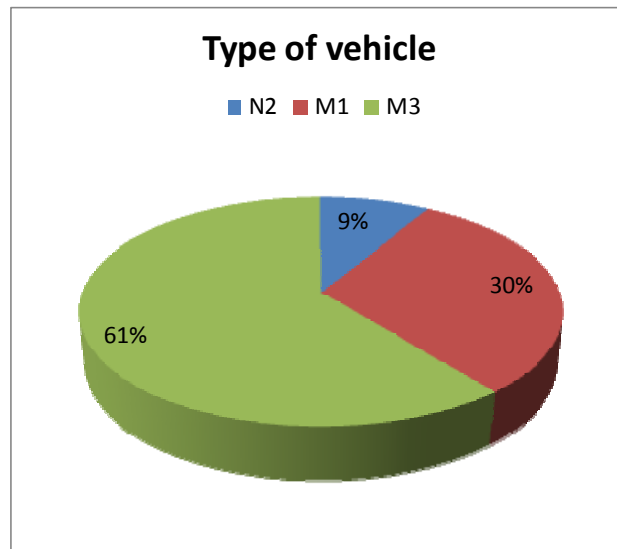

Figure 3.19 Type of vehicles

With the current data there is a majority of cases in the M3 category devoted to urban public transport.

Below appears information concerning the manufacturer and model of vehicle used in different projects.

It is important to highlight the power vehicle information. The information has been homogenized to International System units for better comparison. The power indicated in the database for FCEV, BEV and HEV technologies corresponds to the electric motor; and the power of ICE vehicles corresponds to the thermal engine.

The uses of the vehicle have been classified into three categories depending on the selected projects.

The first classification is "Good Delivery" which includes the UPS and FedEx projects where hybrid vehicles were introduced in the fleet of delivery of goods.

The next category is "Company Fleet PT". This category consists of CUTE, EMT Barcelona, New York City Transit y Electric Bus Evaluation in Seville projects. Three FC vehicles were introduced in public transport companies in 9 European cities in the CUTE project. Through EMT Barcelona and New York City Transit projects new technologies low-carbon such as HEV, use of natural gas and biofuels were introduced in the bus fleet gradually. Through Electric Bus Evaluation Project 4 battery-electric minibus on the route No. 5 of historical center of Seville were introduced.

The category of "Private Use" is composed of the Mini E and Zero Regio projects. The Mini E project is deploying a network of rental vehicles for private use for its evaluation The Zero Regio project was developed in Italy and Germany. In Mantova, New Panda fuel cell vehicles were delivered to Mantova

Town Hall (MTH). The town's employees received training and then used the vehicles over the course of their daily activities in the Lombardia region of Italy. In Frankfurt, A-Class F-CELL vehicles were delivered to the customers Fraport and Infracor, located in the Rhein-Main region of Germany.

Below is the percentage of use of vehicle. Most of the cases correspond to fleets of public transport companies.

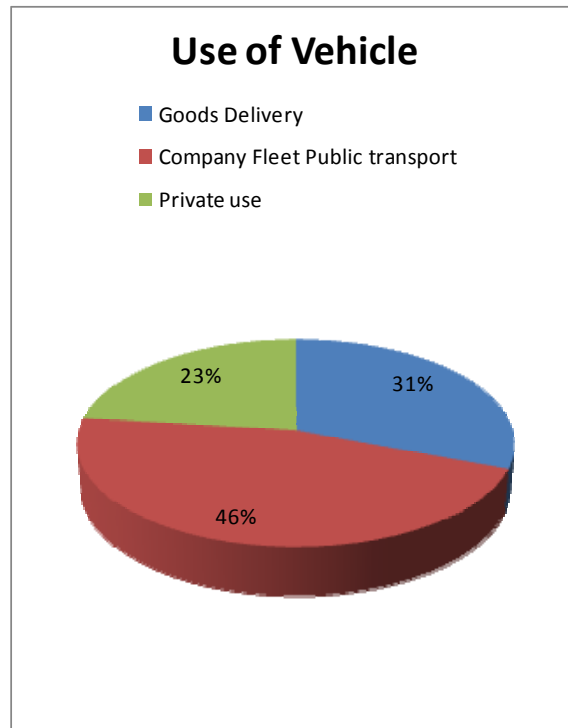

Figure 3.20 Use of vehicle

Finally, the data of kilometers travelled during the project are presented.

The high value of the number of kilometers travelled offer greater reliability of the parameters studied in the database such as fuel economy and emissions calculated.

Project Name	Technology and vehicle							
	Type of Technology	Type of vehicle	Numbers of vehicle	Manufacturer	Model	Power (kW)	Use of vehicle	kilometers
UPS	HEV	N2	6	Mercedes Benz	P70H step van	26	Good Delivery	162.584
UPS	HEV	N2	6	Mercedes Benz	P70H step van	26	Good Delivery	162.584
UPS	HEV	N2	6	Mercedes Benz	P70H step van	26	Good Delivery	162.584
UPS	ICE	N2	6	Mercedes Benz	P70D step van	115	Good Delivery	191.179
UPS	ICE	N2	6	Mercedes Benz	P70D step van	115	Good Delivery	191.179
UPS	ICE	N2	6	Mercedes Benz	P70D step van	115	Good Delivery	191.179
FedEx	HEV	N2	3	Ford	Ford 5.4L EFI Triton V-8	100,0	Good Delivery	15.959
FedEx	HEV	N2	3	Ford	Ford 5.4L EFI Triton V-8	100,0	Good Delivery	15.959
FedEx	HEV	N2	3	Ford	Ford 5.4L EFI Triton V-8	100,0	Good Delivery	15.959
FedEx	ICE	N2	3	Ford	Cummins 5,9L ISB 200 I-S	149,1	Good Delivery	19.080
FedEx	ICE	N2	3	Ford	Cummins 5,9L ISB 200 I-S	149,1	Good Delivery	19.080
FedEx	ICE	N2	3	Ford	Cummins 5,9L ISB 200 I-S	149,1	Good Delivery	19.080
CUTE STOCKHOLM	FCEV	M3	3	Mercedes Benz	Citaro	250	Company fleet PT	91.580
CUTE MADRID	FCEV	M3	3	Mercedes Benz	Citaro	250	Company fleet PT	87.008
CUTE LONDON	FCEV	M3	3	Mercedes Benz	Citaro	250	Company fleet PT	100.250
CUTE STUTTGART	FCEV	M3	3	Mercedes Benz	Citaro	250	Company fleet PT	129.283
CUTE AMSTERDAM	FCEV	M3	3	Mercedes Benz	Citaro	250	Company fleet PT	109.098
CUTE BARCELONA	FCEV	M3	3	Mercedes Benz	Citaro	250	Company fleet PT	37.654
CUTE HAMBURG	FCEV	M3	3	Mercedes Benz	Citaro	250	Company fleet PT	104.473
CUTE LUXEMBOURG	FCEV	M3	3	Mercedes Benz	Citaro	250	Company fleet PT	142.068
CUTE PORTO	FCEV	M3	3	Mercedes Benz	Citaro	250	Company fleet PT	46.929
NEW YORK CITY TRANSIT	HEV	M3	10	BAE system	Orion VII Hyb. BUS	119,3	Company fleet PT	457.767
NEW YORK CITY TRANSIT	ICE	M3	9	DDC S 50	Orion V High floor	205,1	Company fleet PT	307.810
NEW YORK CITY TRANSIT	ICE	M3	10	DDC S 50G	Orion VII CNG. BUS	205,1	Company fleet PT	443.284
ELECTRIC BUS EVALUATION IN SEVILLE	BEV	M3	4	Tecnobus	Gulliver U520ESP	24,8	Company fleet PT	108.936
ELECTRIC BUS EVALUATION IN SEVILLE (AC)	BEV	M3	4	Tecnobus	Gulliver U520ESP	24,8	Company fleet PT	108.936
ELECTRIC BUS EVALUATION IN SEVILLE	ICE	M3	1	Tecnobus	Gulliver U520ESP	24,8	Company fleet PT	108.936
ZERO REGIO GERMANY	FCEV	M1	5	Mercedes-Benz	A-Class	72	Private Use	61.618
ZERO REGIO GERMANY	ICE	M1	1	Mercedes-Benz	A-160	70	Private Use	
ZERO REGIO ITALY	FCEV	M1	3	Fiat	New Panda	70	Private Use	32.983
ZERO REGIO ITALY	ICE	M1	1	Fiat	Fiat Panda	51	Private Use	
EMT BARCELONA	ICE	M3	660	IVECO 2005	GX 127 L	195	Company fleet PT	
EMT BARCELONA	ICE	M3	124	IVECO 2005	GX 127 L	195	Company fleet PT	
EMT BARCELONA	HEV	M3	3	CASTROSUA	TEMPUS	84	Company fleet PT	
Mini E UNITED KINGDOM	BEV	M1	40	BMW	Mini Cooper	150	Private Use	
Mini E LOS ANGELES	BEV	M1	250	BMW	Mini Cooper	150	Private Use	
Mini E NEW YORK	BEV	M1	250	BMW	Mini Cooper	150	Private Use	
Mini E BERLIN	BEV	M1	50	BMW	Mini Cooper	150	Private Use	
Mini E MUNICH	BEV	M1	40	BMW	Mini Cooper	150	Private Use	

Figure 3.21 Technology sheet

3.2.5 Fuel and costs

This sheet contains all the information on fuel used, as well as calculations to determine harmonized fuel consumption for the different technologies.

The group of data called "*Fuel and cost*" comprises the following fields:

- Fuel
- Fuel storage
- Fuel economy
- Expected range
- Cost.

The section *fuel* details the type of fuel used in each vehicle. In the case of hybrid vehicles in addition to electricity, the fossil fuel used is also included (gasoline or diesel).

The database collects information on "Fuel storage". This section is divided into three categories:

- Liquid Fuel Storage (in litres). This is the case of liquid fossil fuels and biofuel blends (gasoline, diesel and biodiesel).
- Electricity Storage (in kWh). The fuel used is electricity from the grid with energy mix of each country. HEVs use liquid fuel and electricity stored in batteries.
- Gaseous Fuel (in Kg): The fuel used is a gas (hydrogen or natural gas) at different pressures (350 or 700 in the case of hydrogen and 200 - 220 bar in the case of natural gas)

In order to homogenize and make a comparison between different types of fuel and storage, a column of Fuel Energy storage in MJ is added.

The highest energy density of fossil fuel provides high values of stored energy. In the case of BEV, this stored energy is much lower. This difference can be seen in the case of Zero Regio gasoline vehicle in Germany, which has 12.7 times more stored energy than a BEV of MINI E. However, the inefficiency of the ICE compared with BEV makes Expected range value is only 2.8 times ICE higher than BEV. Therefore further work is required in storage systems with higher energy density for BEV that will make these differences may be shortened.

This sheet has one of the most important parameters in the database which is the *fuel economy*. This parameter is required for the calculation of CO₂ emissions both WTT and TTW and therefore the final value of WTW. Similarly, it is necessary to calculate energy consumption WTT, TTW and WTW. Fuel economy is extracted directly from the selected real demonstration projects, and

it is harmonized in the database to compare different types of technologies. The units used are (km/l of gasoline equivalent) and (km/MJ fuel).

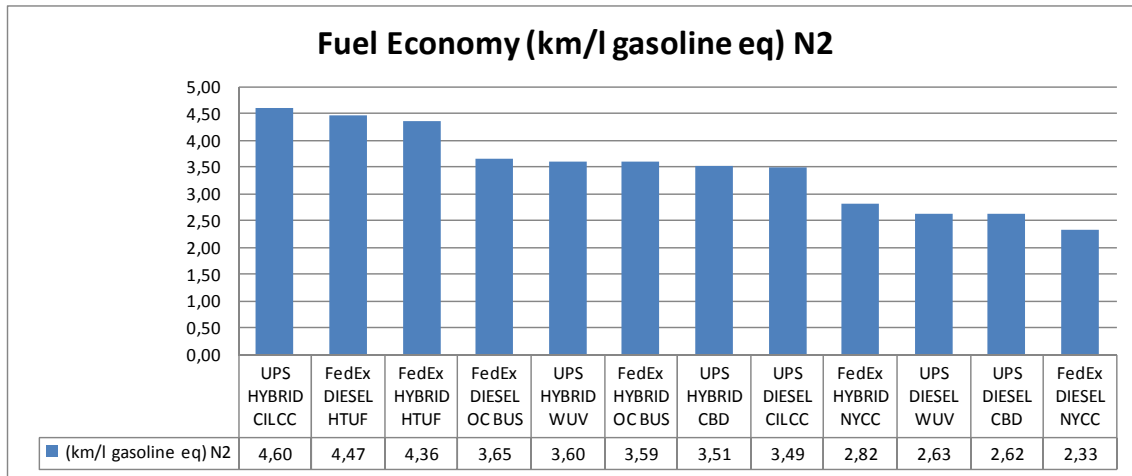

Figure 3.22 Fuel economy in N2 vehicles

This graph shows the fuel economy values for vehicles of the same category N2.

Emphasize that the projects developed by UPS and FedEx include three cases for each fuel. This is because a study of fuel consumption with different drive cycle (includes commentary with the name of the drive cycle). The main difference between the drive cycles is the average velocity and kinetic Intensity (ft^{-1}). Kinetic intensity is a calculated “macro-characteristic” that represents the transient intensity (accelerations and decelerations) of a particular drive cycle.

This graph shows that the hybridization of vehicle fuel economy increases as seen in the experience of UPS. For the case of FedEx, the hybrid vehicle uses gasoline, in comparison with ICE using diesel. While the hybrid electric element imparts higher efficiency, this advantage is offset in part by the lower liquid fuel energy content (gasoline compared with diesel) and lower thermal efficiency (spark ignition compared with compression ignition). The NYCC drive cycle exhibits the highest kinetic intensity, characterized by many acceleration and deceleration events. HEV acceleration demands are shared by the gasoline engine, the battery, and the electric motor, while the diesel vehicle relies solely on its diesel engine. The electric power train is a higher-efficiency option for these transient events. HEV deceleration events allow for the recapture of energy via regenerative braking, while this energy is unrecoverable and lost by the diesel vehicle. For these reasons, high kinetic-intensity drive cycles are a better application for HEVs than for diesel vehicles.

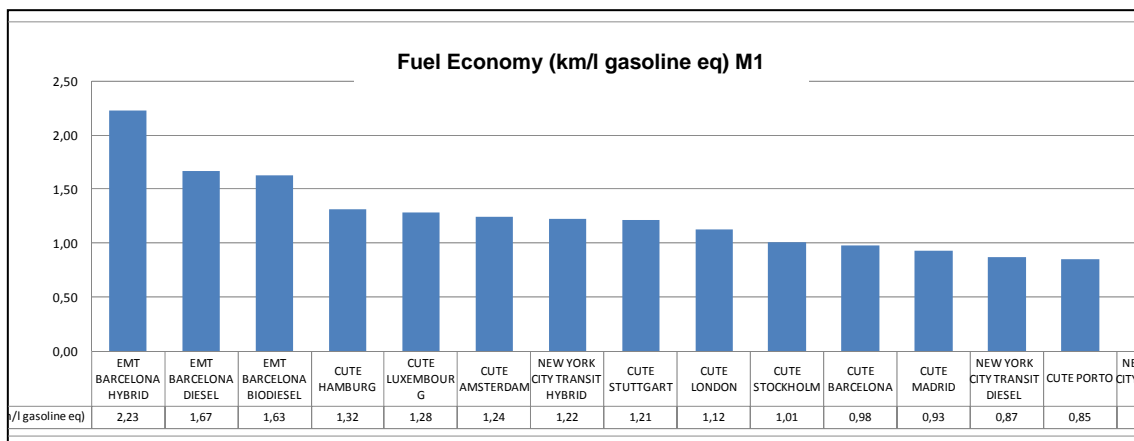

Figure 3.23 Fuel economy in M1 vehicles

Figure 3.23 shows the fuel economy for vehicles of category M1. It has not represented the experience of battery-electric minibus to Seville despite also being a vehicle type M1. In this case the battery-electric minibus has a fuel economy of 23.71 km / l gasoline eq. These values are due to the high efficiency of electric motor and the difference in dimensions, weight and motor power between Citaro bus of 250 kW of CUTE project and minibus of Sevilla TecnoBus of 24.8 kW.

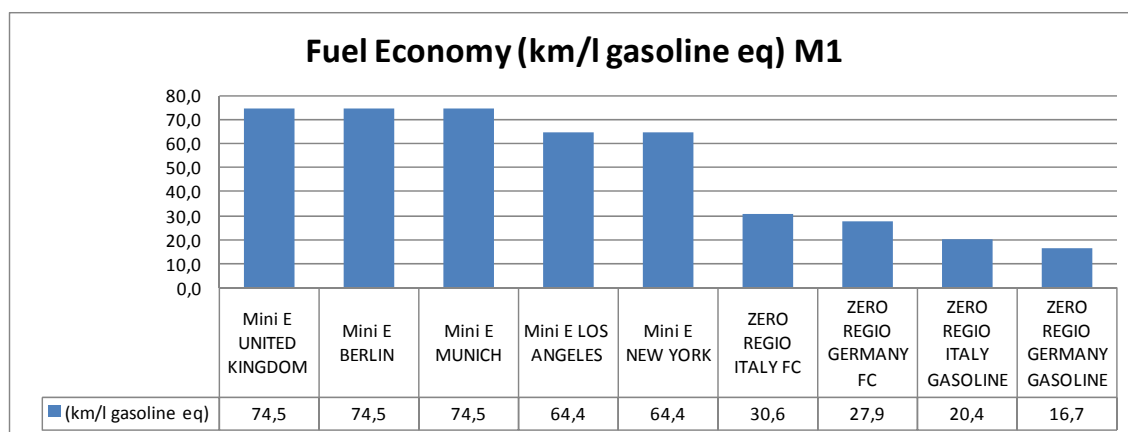

Figure 3.24 Fuel economy in M1 vehicles

Figure 3.24 shows the difference in fuel consumption between the technologies of BEV, FCEV and ICE gasoline for vehicles of category M1. Figure 3.25 shows different technologies for different vehicle categories. This graph shows the influence on fuel consumption depending on factors such as weight and power of the vehicle.

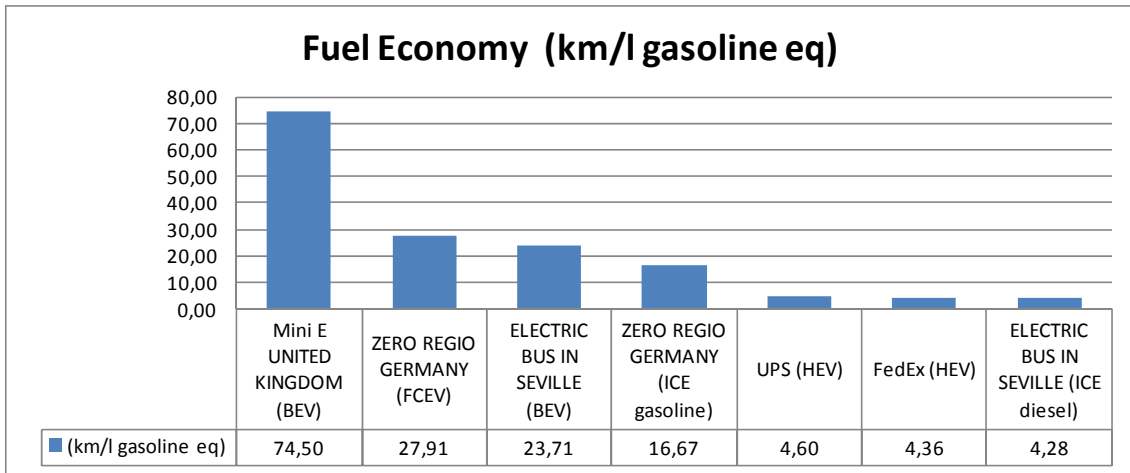

Figure 3.25 Fuel economy

Note the greater efficiency of BEV versus the FCEV and ICE diesel. It is the case of Mini E with a weight of 1,460 kg and a power of 150 kW electric motor versus Mercedes A-Class with 1,350 kg and a power of 65 kW electric motor. The battery-electric Minibus of Seville weighs 6045 kg and has a power of 24.8 kW. The delivery vehicles of FedEx have a weight of 4,300 kg and a power of 100 kW.

With fuel economy parameter, calculations of emissions and energy consumption WTW are performed. The choice of technology for transportation at a particular location should be based on the global study of energy consumption and emissions WTW.

The following chart shows the percentage of cases distributed according the expected range for the different types of technologies considered.

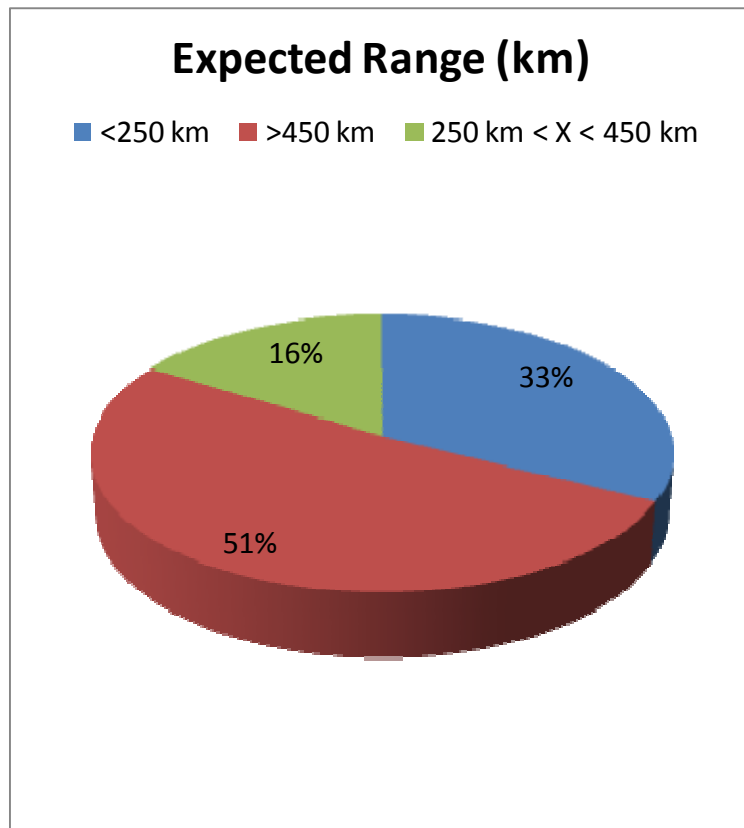

Figure 3.26 Expected range

The same sheet presents data acquisition costs, maintenance and operation. These data are scarce in the selected projects, and they are approximate in some cases, due to these new technologies are advancing rapidly and the market prices can vary over short periods of time. Highlight the Mini E project in which the cost is not acquisition but a monthly leasing.

Project Name	Fuel	Fuel storage				Fuel economy		Expected range (km)	Costs		
		Liquid Fuel Storage (l)	Electricity Storage (kWh)	Gaseous Fuel Storage (kg)	Energy Storage (MJ)	Fuel economy (km/l gasoline eq)	Fuel economy (km/MJ)		Acquisition costs (M€)	Operation costs (€/km)	Maintenance costs (€/km)
UPS	Diesel/Electricity	170,34	1,80		6.083,58	4,60	0,1429	869		0,14	0,08
UPS	Diesel/Electricity	170,34	1,80		6.083,58	3,60	0,1118	680		0,14	0,08
UPS	Diesel/Electricity	170,34	1,80		6.083,58	3,51	0,1092	664		0,14	0,08
UPS	Diesel	170,34			6.077,10	3,49	0,1084	659		0,18	0,09
UPS	Diesel	170,34			6.077,10	2,63	0,0819	498		0,18	0,09
UPS	Diesel	170,34			6.077,10	2,62	0,0814	495		0,18	0,09
FedEx	Gasoline/electricity	208,20	2,40		7.436,20	2,82	0,0875	650		0,28	0,09
FedEx	Gasoline/electricity	208,20	2,40		7.436,20	3,59	0,1115	829		0,28	0,09
FedEx	Gasoline/electricity	208,20	2,40		7.436,20	4,36	0,1354	1.007		0,28	0,09
FedEx	Diesel	170,34			6.077,10	2,33	0,0725	440		0,27	0,10
FedEx	Diesel	170,34			6.077,10	3,65	0,1134	689		0,27	0,10
FedEx	Diesel	170,34			6.077,10	4,47	0,1390	844		0,27	0,10
CUTE STOCKHOLM	Hydrogen			44	5.276,92	1,01	0,0313	165	1.250		
CUTE MADRID	Hydrogen			44	5.276,92	0,93	0,0290	153	1.250		
CUTE LONDON	Hydrogen			44	5.276,92	1,12	0,0349	184	1.250		
CUTE STUTTGART	Hydrogen			44	5.276,92	1,21	0,0377	199	1.250		
CUTE AMSTERDAM	Hydrogen			44	5.276,92	1,24	0,0386	204	1.250		
CUTE BARCELONA	Hydrogen			44	5.276,92	0,98	0,0304	161	1.250		
CUTE HAMBURG	Hydrogen			44	5.276,92	1,32	0,0409	216	1.250		
CUTE LUXEMBOURG	Hydrogen			44	5.276,92	1,28	0,0399	211	1.250		
CUTE PORTO	Hydrogen			44	5.276,92	0,85	0,0265	140	1.250		
NEW YORK CITY TRANSIT	Diesel/Electricity	378,54			13.504,66	1,22	0,0380	513		0,27	0,59
NEW YORK CITY TRANSIT	Diesel	473,175			16.880,83	0,87	0,0272	459			
NEW YORK CITY TRANSIT	Natural Gas	473,175			16.880,83	0,65	0,0203	342		0,49	0,62
ELECTRIC BUS EVALUATION IN SEVILLE	Electricity		45		162	23,71	0,7368	119			
ELECTRIC BUS EVALUATION IN SEVILLE (AC)	Electricity		45		162	19,78	0,6146	100			
ELECTRIC BUS EVALUATION IN SEVILLE	Diesel	100			3.567,57	4,28	0,1329	474			
ZERO REGIO GERMANY	Hydrogen			1,8	215,874	27,91	0,8672	187			
ZERO REGIO GERMANY	Gasoline	50			1.609,20	16,67	0,5179	833			
ZERO REGIO ITALY	Hydrogen			2,35	281,8355	30,59	0,9506	268			
ZERO REGIO ITALY	Gasoline	35			1.248,65	20,41	0,6341	792			
EMT BARCELONA	Diesel	280			9.989,18	1,67	0,0519	519		0,42	0,18
EMT BARCELONA	Biodiesel	280			9.959,31	1,63	0,0506	504		0,43	0,18
EMT BARCELONA	Diesel/Electricity	280			9.989,18	2,23	0,0692	691			
Mini E UNITED KINGDOM	Electricity		35		126,00	74,50	2,3148	292	400,00		
Mini E LOS ANGELES	Electricity		35		126,00	64,40	2,0011	252	600,00		
Mini E NEW YORK	Electricity		35		126,00	64,40	2,0011	252	600,00		
Mini E BERLIN	Electricity		35		126,00	74,50	2,3148	292	400,00		
Mini E MUNICH	Electricity		35		126,00	74,50	2,3148	292	400,00		

Figure 3.27 Fuel and costs sheet

3.2.6 Emissions

This sheet identifies the emission of CO₂ and other common contaminants emitted by the vehicles in the considered projects.

This set of data is composed of the following fields:

- CO₂ Emissions WTW
 - Well to tank (WTT)
 - Fuel from renewable source
 - Tank to Wheel (TTW)
 - Total emission.
- Other emissions TTW
 - NO_x
 - CO
 - THC
 - Particles PM10
 - CH₄
 - SO

The first column is the CO₂ emissions for the WTT process. These values are taken from different projects depending on the source of fuel and the country or geographical area of the project.

As above mentioned, the study by EUCAR, CONCAWE and JRC (the Joint Research Centre of the EU Commission) called “WELL-TO-WHEELS ANALYSIS OF FUTURE AUTOMOTIVE FUELS AND POWERTRAINS IN THE EUROPEAN CONTEXT” version 2C, March 2007 has been used for projects developed in Europe.

The document contains a wide variety of fuels from different sources and production processes. The following matrix summarizes the main combinations.

Fuel		Resource	Gasoline,	CNG	LPG	Hydrogen (comp., liquid)	Synthetic diesel (Fischer- Tropsch)	DME	Ethanol	MT/ETBE	FAME/FAEE	Methanol	Electricity
			Naphtha (2010 quality)										
Crude oil			X										
Coal						X ⁽¹⁾	X ⁽¹⁾	X				X	X
Natural gas	Piped			X		X ⁽¹⁾	X	X				X	X
	Remote			X ⁽¹⁾		X	X ⁽¹⁾	X ⁽¹⁾		X		X	X
LPG Remote ⁽³⁾					X					X			
Biomass	Sugar beet								X	↕			
	Wheat								X	X			
	Wheat straw								X				
	Sugar cane								X				
	Rapeseed									X			
	Sunflower									X			
	Woody waste					X	X	X	X			X	
	Farmed wood					X	X	X	X			X	X
	Organic waste												X
	Black liquor					X	X	X				X	X
Wind													X
Nuclear													X
Electricity						X							

⁽¹⁾ with/without CO₂ capture and sequestration

⁽²⁾ Biogas

⁽³⁾ Associated with natural gas production

Table 1 Primary energy resources and automotive fuels. Source JRC

Below is a sample table on the information supplied by the studio to the case of fossil fuels.

	Standard step	Energy expended (MJx/MJf)				Net GHG emitted (g CO ₂ eq/MJf)			CO ₂ g/MJ	CH ₄ g/MJ	N ₂ O g/MJ			
		Total primary			Fossil	Best est.	min	Max						
		Best est.	min	Max										
COG1	Crude oil to gasoline													
	Crude Extraction & Processing	1	0.03	0.01	0.04				3.6	0.00	0.000			
	Crude Transport	3	0.01						0.9	0.00	0.000			
	Refining	4	0.08	0.06	0.10				7.0	0.00	0.000			
	Distribution and dispensing	5	0.02						1.0	0.00	0.000			
	Total pathway		0.14	0.12	0.17	0.14			12.5	11.1	14.6	12.5	0.00	0.000
COD1	Crude oil to diesel													
	Crude Extraction & Processing	1	0.03	0.01	0.04				3.7	0.00	0.000			
	Crude Transport	3	0.01						0.9	0.00	0.000			
	Refining	4	0.10	0.08	0.12				8.6	0.00	0.000			
	Distribution and dispensing	5	0.02						1.0	0.00	0.000			
	Total pathway		0.16	0.14	0.18	0.16			14.2	12.6	16.0	14.2	0.00	0.000
CON1	Crude oil to naphtha													
	Crude Extraction & Processing	1	0.03	0.01	0.04				3.5	0.00	0.000			
	Crude Transport	3	0.01						0.9	0.00	0.000			
	Refining	4	0.05	0.04	0.06				4.4	0.00	0.000			
	Distribution and dispensing	5	0.02						1.0	0.00	0.000			
	Total pathway		0.11	0.10	0.13	0.11			9.8	8.5	11.3	9.7	0.00	0.000

Table 2 Conventional fuel. Source JRC

The study “Well-to-Wheels Analysis of Advanced Fuel / Vehicle Systems - A North American Study of Energy Use, Greenhouse Gas Emissions, and Criteria Pollutant Emissions”, by General Motors in 2005 has been used for projects developed in USA.

A WTW analysis performed in this study includes many WTT activities related to production and transportation of feedstocks and fuels. Figure 3.20 is a simplified diagram showing calculation logic for energy use and emissions associated with WTT production activities.

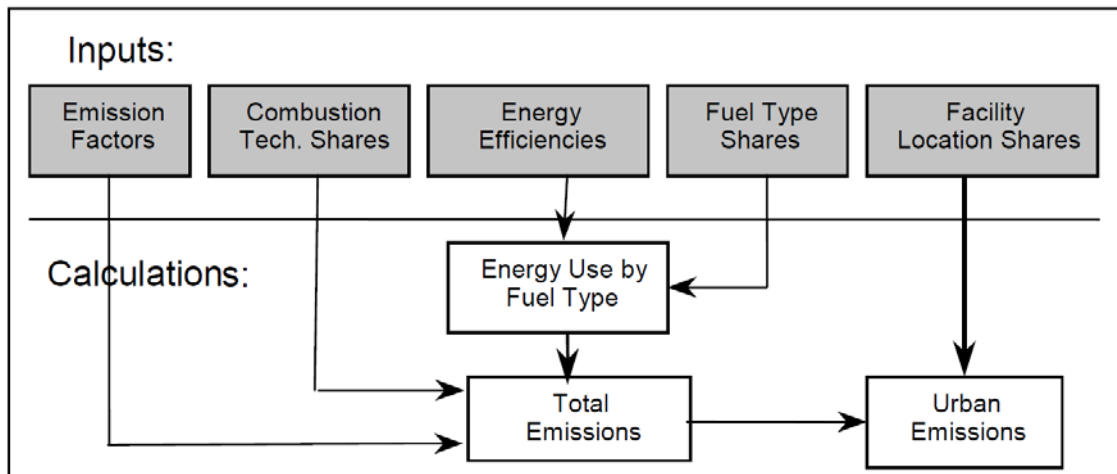

Figure 3.28 Calculation Logic for Well-to-Tank Energy Use and Emissions for Activities Related to Production of Feedstocks and Fuels

UPS, FedEx and New York City Transit projects have used the same value of CO₂ emissions WTT because UPS vehicles use diesel and fuel consumption values of FedEx and New York City Transit are calculated on "equivalents diesel". The value is extracted from Appendix C of document "Well-to-Wheels Analysis of Advanced Fuel / Vehicle Systems - A North American Study of Energy Use, Greenhouse Gas Emissions, and Criteria Pollutant Emissions" section "10 ppm low-sulfur diesel (90%)".

For CUTE project, values of CO₂ emission WTT used vary depending on the source of fuel.

The following graph shows the origin and H₂ production process of the CUTE project.

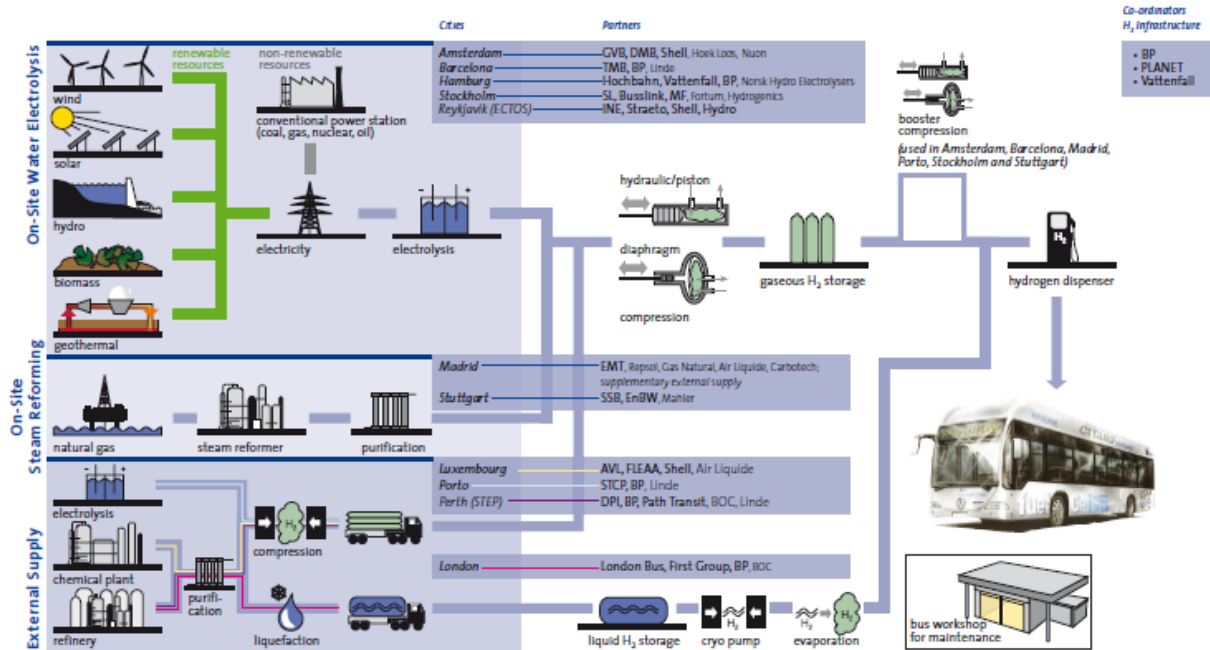

Figure 3.29 Hydrogen Supply Pathways in CUTE. Source CUTE

The hydrogen production methods used in this project are:

- In Stockholm and Amsterdam, hydrogen was produced from green energy. Therefore the value of CO₂ emissions of section “WDEL1 CH1 Wind to compressed hydrogen via central electrolysis” was used.
- In Madrid and Stuttgart, hydrogen was produced from on-site steam reforming. Therefore the value of CO₂ emissions of section “GMCH1 EU-mix NG supply to on-site hydrogen production and compression” was used.
- In London, hydrogen was supplied externally in liquid. Therefore the value of CO₂ emissions of section “GPLCHb Piped NG to central production of liquid hydrogen, road distribution and on-site vaporisation/compression” was used.
- In Barcelona, hydrogen production by electrolysis used 50% from renewable origin electricity and 50% from energy obtained from the grid. For the contribution of renewable sources, data used were “WDEL1 CH1 Wind to compressed hydrogen via central electrolysis” and for the energy from the grid, values from Spanish electricity Grid were used.
- In Luxemburg and Porto, hydrogen was supplied externally in gaseous. Therefore the value of CO₂ emissions of section “GPEL1b/CH2 Piped NG, 4000 km, CCGT, central electrolysis, pipe” was used.

The use of actual data for individual sites makes the study much more close to reality, can get a good approximation to the final values of emission and energy consumption.

Particularly for some projects more accurate data have been used. Is the case *Electric bus evaluation in Seville*, which data specific emissions and energy consumption for electricity production in Spain was used. These data were extracted from the Spanish Electrical Grid National Organization. For the item of del minibus ICE diesel, the value of CO₂ emissions of section “COD1 Crude oil to diesel” of document WELL-TO-WHEELS ANALYSIS OF FUTURE AUTOMOTIVE FUELS AND POWERTRAINS IN THE EUROPEAN CONTEXT” was used.

Similarly, for the *Zero Regio* project specific values collected in the original project were used. For the item of ICE with gasoline, the value of CO₂ emissions of section “COG1 Crude oil to gasoline” of document “WELL-TO-WHEELS ANALYSIS OF FUTURE AUTOMOTIVE FUELS AND POWERTRAINS IN THE EUROPEAN CONTEXT” was used.

For the project EMT Barcelona, the item "30% biodiesel" has used the proportional part of value of CO₂ emissions for the production of diesel and for the biofuel production collected in section “ROFA4 Rapeseed to FAME (RME)”.

For Mini E project the value of CO₂ emissions of section “EMEL1 EU-mix electricity” was used for experiences developed in European countries and for experiences developed in the U.S., IEA data have been used.

In each of the WTT items that make up the database appears an accompanying commentary to the hypothesis of fuel production.

The emission values are conditioned directly by the source of fuel. Column *Fuel from renewable source* determines the percentage of renewable energy used to produce fuel. In 74% of the experiences, the fuel used was from non-renewable energy sources.

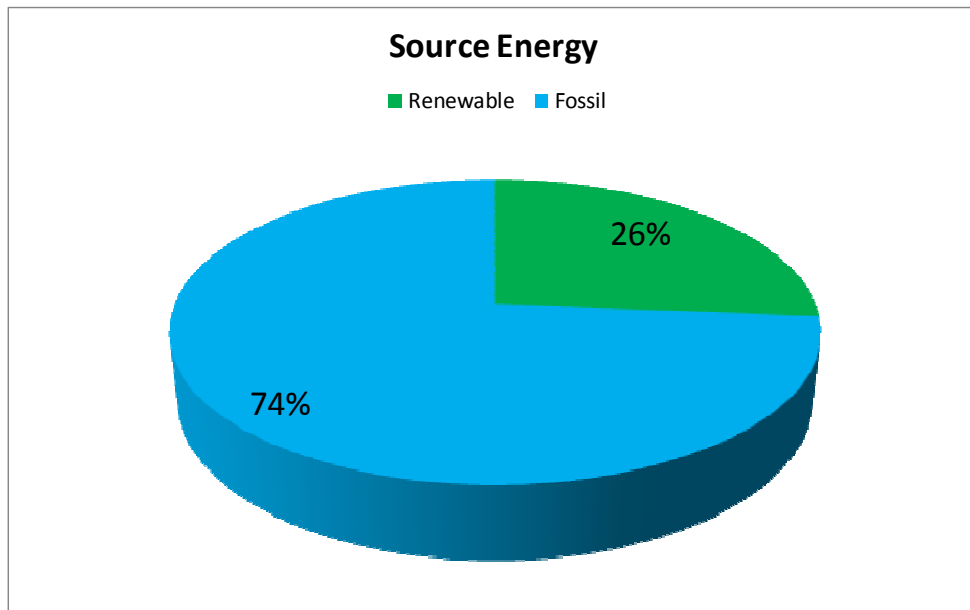

Figure 3.30 Source energy

The TTW CO₂ emissions correspond to the values measured in each of the selected real experiences to complete the database. Data have been homogenized to compare the different cases in the same SI units (g/km).

For the final value WTW were calculated TTW emissions in g/MJ using the fuel economy in km/MJ.

Adding both CO₂ emissions, WTT and TTW, the total value of WTW CO₂ emissions is obtained.

A comparative study of CO₂ emissions WTT and TTW was conducted, grouped by type of vehicle under the community rules of transportation. Classified according to directive 2007/46 CE.

In this comparative of emissions, experience of BEV of Seville is not 100% comparable, despite being M3, because it is a minibus and differences in weight and motor power do that comparison is not homogeneous. The graph 27 shows the results for the Electric Bus Evaluation project in Seville. CO₂ emissions for ICE diesel minibus are 7.25 times higher the BEV and 6 times higher in the case of using air conditioning system in the BEV.

The climatic conditions of the city influence the emission of CO₂. Due to the high temperatures of the city of Seville in the summer months, the use of air conditioning in vehicles is required. This consumption energy supposes an increase in emissions of 19% compared with BEV without air conditioning.

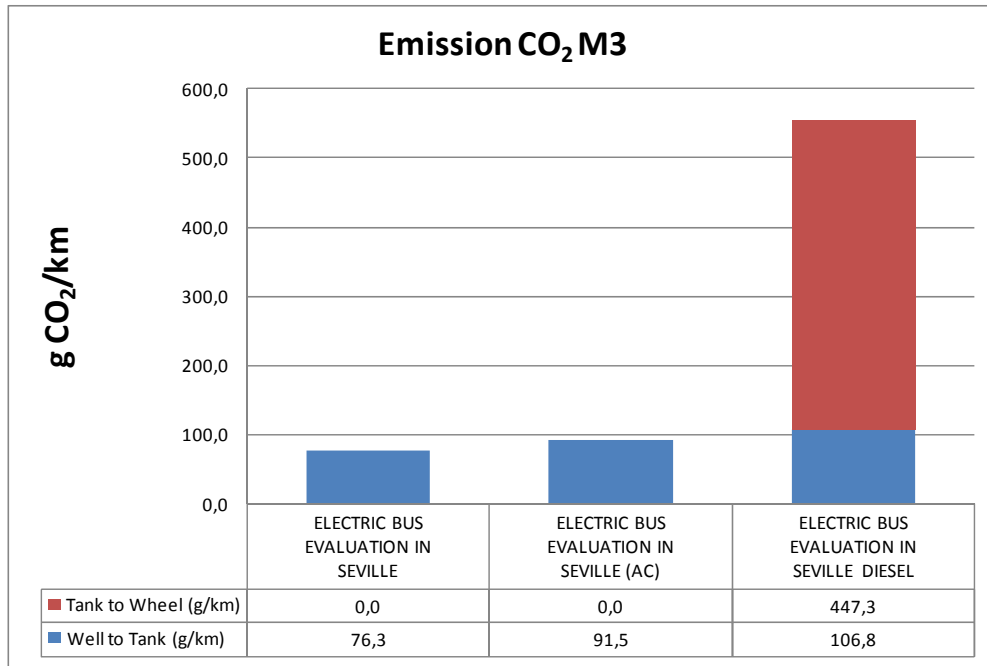

Figure 3.31 Emission CO₂ WTW experience in Seville (M3)

When sustainable technologies with renewable fuels are combined and production of the fuel is produced on site, differences with respect to traditional modes of transport are noticeable.

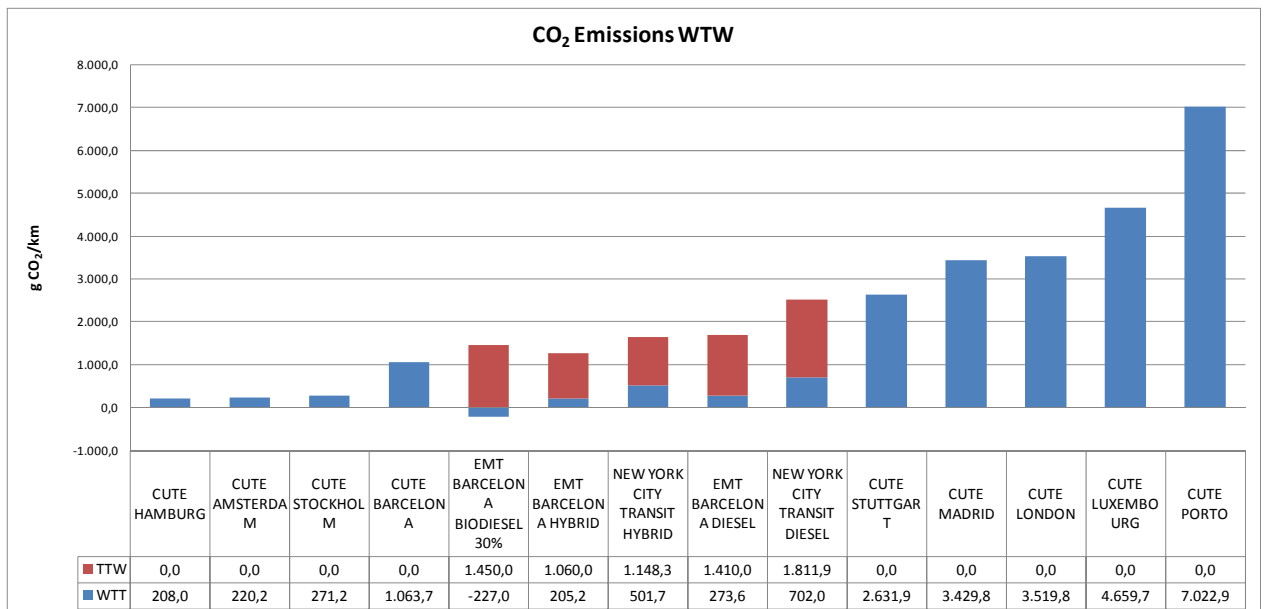

Figure 3.32 Emission CO₂ WTW M3

WTW analysis emphasizes the importance of the source of fuel and mode of production, as is seen in the items of the CUTE project in Hamburg, Amsterdam and Stockholm.

Comparing the graphs obtained in the ITACA project is observed that experiences with the same technology obtain final results of emission very different:

H₂ is produced on-site using electricity from renewable sources in Hamburg.

H₂ is produced by electrolysis with electricity from the grid, is compressed, transported and consumed in Porto.

Comparing these two cases, the final value of CO₂ emissions WTW of Porto is 33 times higher the value of emissions of Hamburg These differences are caused mainly, among other things (i.e. difference in elevation, orographic), to the inefficiency in the fuel production process and the origin of the energy used for production.

Orographic characteristics of cities affect the emission values. It is noted in the items of CUTE Hamburg, Amsterdam and Stockholm that starting from the same source of hydrogen supply, values of emissions CO₂ obtained are different. This is because the first two cities have low relief and Stockholm has medium relief. This leads to higher fuel consumption in Stockholm and therefore CO₂ emission values produced are higher.

Technological improvement in vehicles, such as hybridization, reduces the total emissions of CO₂ and energy consumption. Hybridization directly influences the reduction of fuel consumption values. This reduction in CO₂ emissions is observed in items of HEV in New York City Transit and ETM Barcelona. For items of vehicles of category M1 is also very useful WTW analysis.

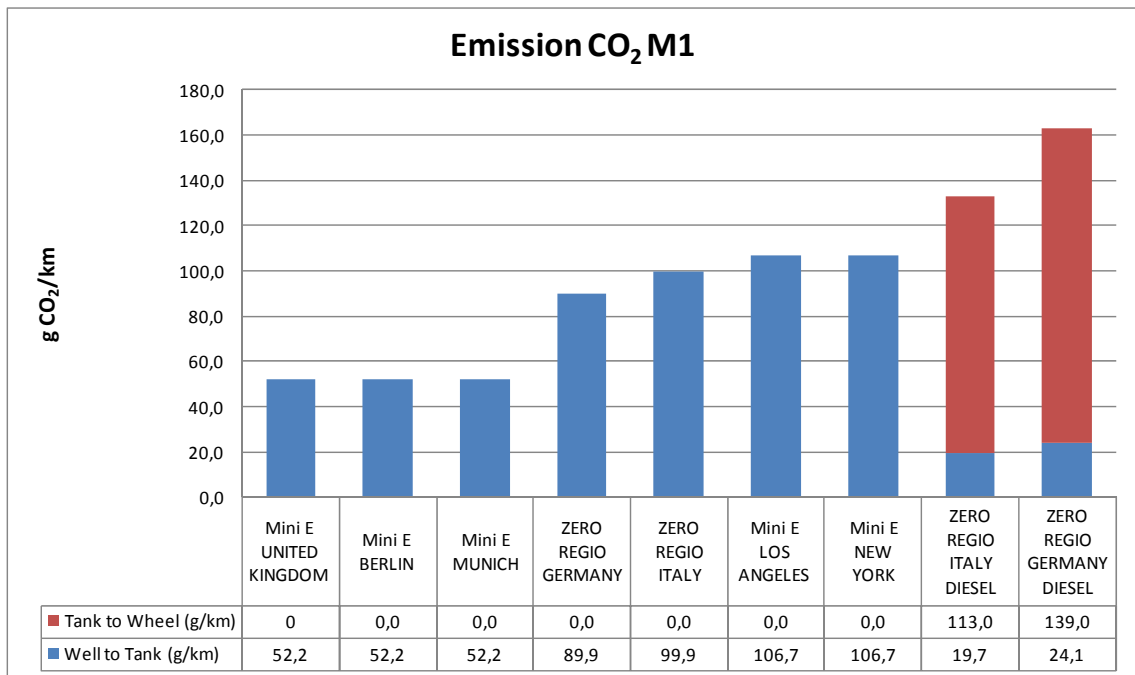

Figure 3.33 Emission CO₂ WTW M1

The items of Mini E UK, Berlin and Munich contain the same value of WTT emissions because the same value of CO₂ emission extracted from the study of the JRC has been taken.

To obtain more accurate values for each item, the user of the database can enter values of CO₂ emission WTT of each city or country, thereby obtaining more accurate results.

With regard to CO₂ emissions for M1 vehicles become manifest the importance of fuel source.

A BEV in New York or Los Angeles produces more CO₂ emissions than a FCEV in Europe. This is because the electrical energy used as fuel for battery-electric vehicles in the U.S. has a higher emission of CO₂ in the production. Specifically, the U.S. energy mix is consisted of 52% of coal as primary energy for electricity production and only 10% is from renewable sources. This leads to high levels of CO₂ in the generation of final fuel.

Source	Efficiency, LHV ²⁶		GHG Emissions (g CO ₂ /MJ) ²⁷
	2006	2030	
Coal	33%	36%	94
NG	37%	43%	57
Petroleum	35%	34%	78
Nuclear	33%	33%	0
Renewables ²⁸	33%	38%	0
Charging	90%	90%	--
Transmission ²⁹	91%	91%	--

	2006	2030
Coal	52%	58%
Petroleum	3%	2%
Natural Gas	16%	15%
Nuclear	20%	16%
Renewable ³⁰	10%	9%

Figure 3.34 Critical assumptions about characteristics of the electric grid. Current and future US average grid mix. (Source: EIA 2006)

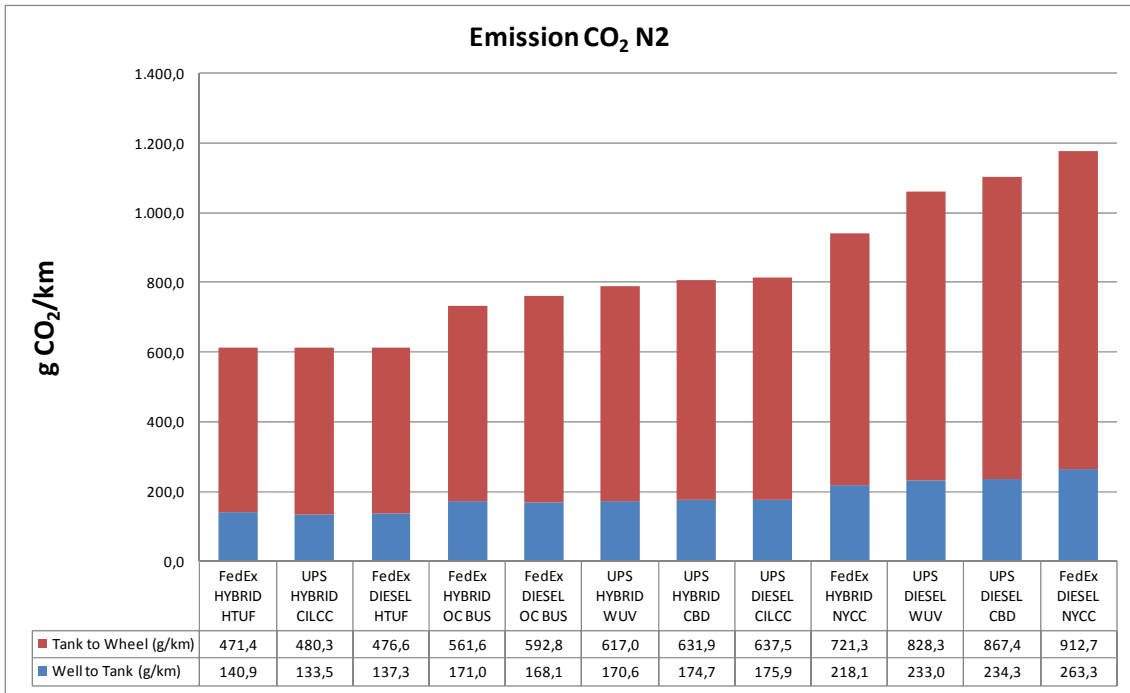

Figure 3.35 Emission CO₂ WTW N2

The results of Figure 3.31 show that in the FedEx project the emissions of CO₂ of hybrid vehicles with gasoline motor are similar to emissions of diesel vehicles in the same circuit. When kinetic intensity increases due to the number of stops and average speed is low, as in the circuit NYCC, the differences are greater.

In the UPS case where the hybridization is performed in a diesel vehicle, the results of CO₂ emission for hybrid vehicles is always less than the ICE vehicle in all circuits tested.

Based on the results of projects UPS and FedEx is concluded that hybridization obtains better results for circuits where the average speed is between 35 and 45 km / h and the number of stops is high. In these circumstances the time of operating of electric motor increases and regenerative braking decreases fuel consumption of vehicle.

As mentioned above, the technical characteristics of the vehicle of weight and power directly affect fuel consumption value having an impact on CO₂ emission values WTT and TTW.

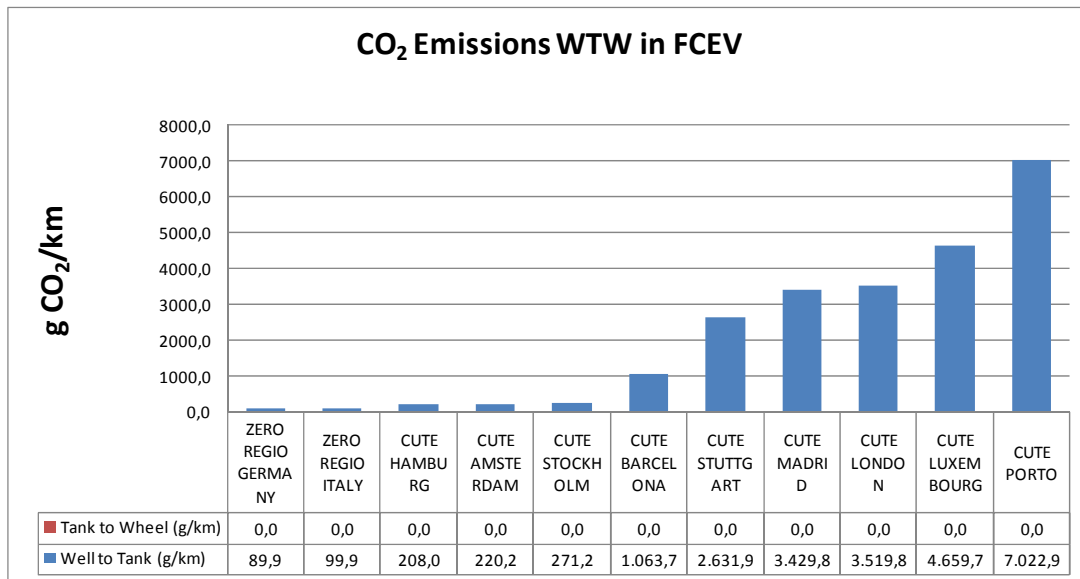

Figure 3.36 CO₂ emission WTW in FCEV

Obviously, as shown in the figure, vehicles with less weight and lower power produce less emissions due to a minor fuel consumption.

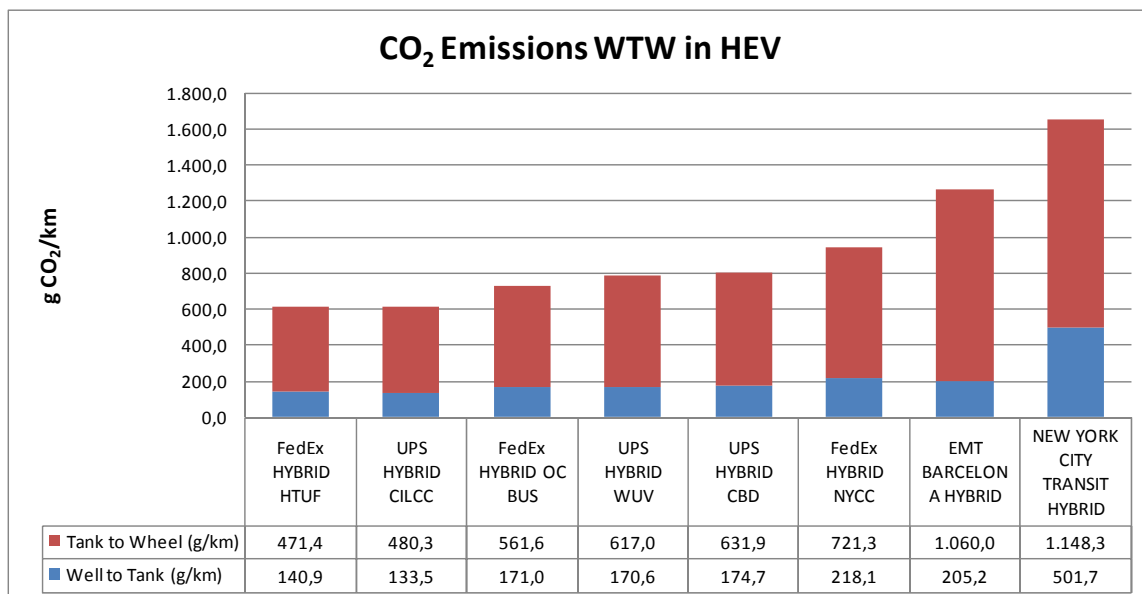

Figure 3.37 CO₂ emission WTW in HEV

The following graph shows how the origin of fuel have a direct influence on the value of the final emissions. When emissions of BEV are represented is seen as the emissions of Minibus Seville are lower than for a Mini E in the U.S. The reason for these emissions is the energy mix used. The energy mix of Spain produces approximately 56 g / MJ generated due to the higher percentage of renewable energy and reduced use of coal as primary energy. In the U.S. where the percentage of renewable energy is less than 10% and coal use is dominant, emission values are approximately 213 g / MJ generated.

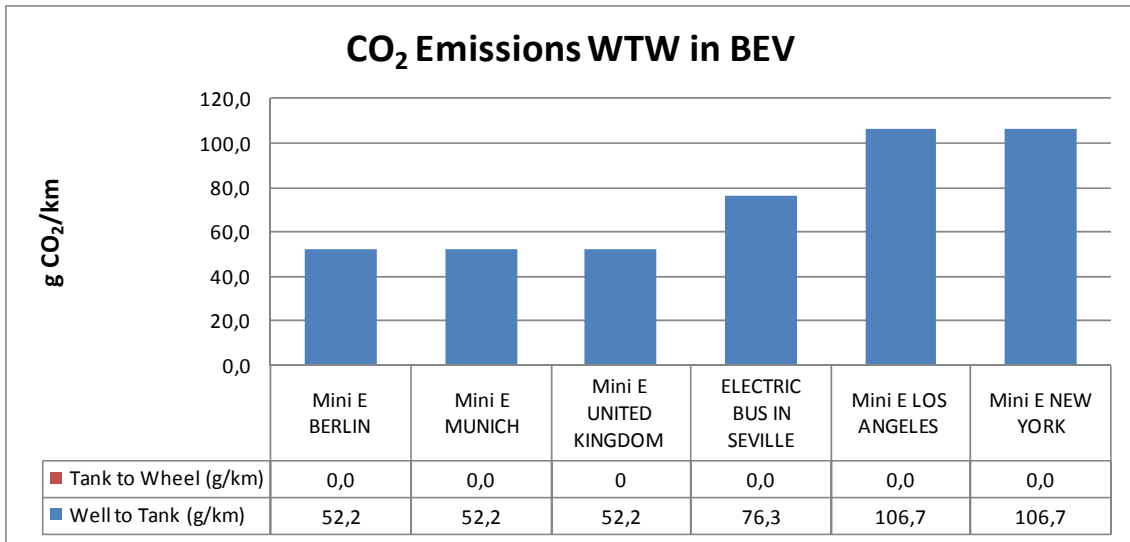

Figure 3.38 CO₂ emission WTW in BEV

ITACA project focuses on calculations of CO₂ emission and energy consumption, but, additionally, emission data of other pollutants such as NOx, CO, PM10, THC, CH₄ and SO_x have been also included into database.

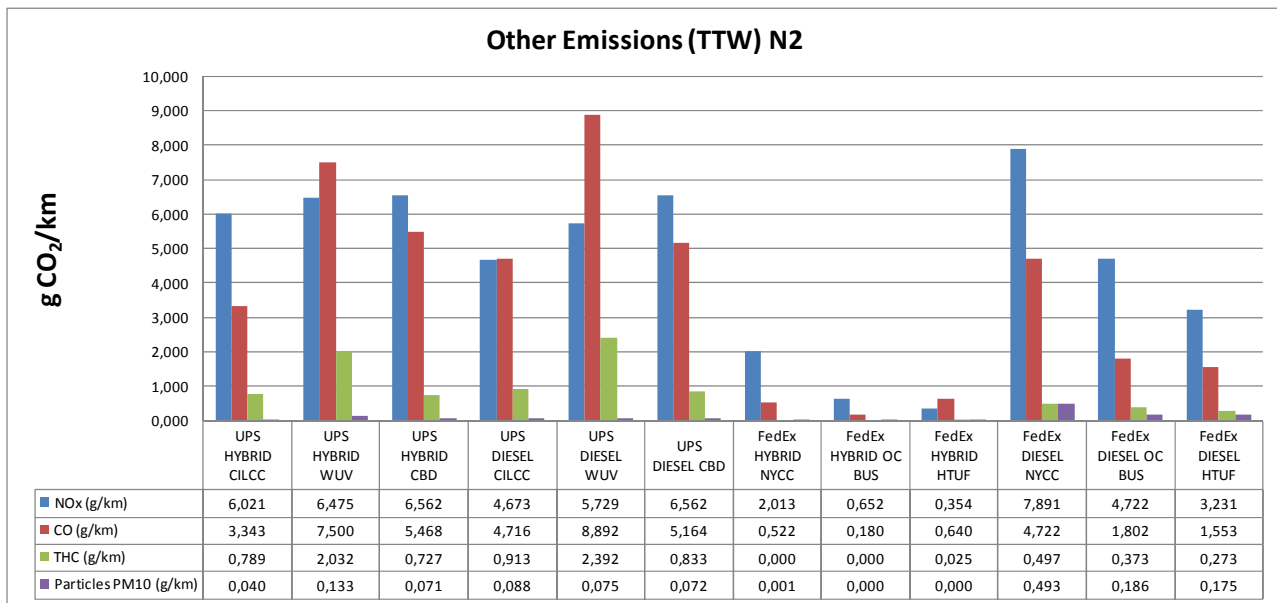

Figure 3.39 Other emission TTW N2

Project	CO ₂ Emissions WTW					Other Emissions (TTW)					
	Name	Well to Tank (g/MJ)	Fuel from renewable source (Totally or Partially)	Tank to Wheel (g/km)	Tank to Wheel (g/MJ)	Total emission (g/Km)	NOx (g/km)	CO (g/km)	THC (g/km)	Particles PM10 (g/km)	CH ₄ (g/km)
UPS	19,07	No	480,32	68,63	613,81	6,02	3,34	0,79	0,04		
UPS	19,07	No	617,02	68,97	787,66	6,47	7,50	2,03	0,13		
UPS	19,07	No	631,93	68,98	806,67	6,56	5,47	0,73	0,07		
UPS	19,07	No	637,53	69,14	813,41	4,67	4,72	0,91	0,09		
UPS	19,07	No	828,29	67,81	1.061,27	5,73	8,89	2,39	0,07		
UPS	19,07	No	867,43	70,60	1.101,78	6,56	5,16	0,83	0,07		
FedEx	19,07	No	721,35	63,10	939,41	2,01	0,52		0,00		
FedEx	19,07	No	561,60	62,64	732,60	0,65	0,18		0,00		
FedEx	19,07	No	471,37	63,81	612,27	0,35	0,64	0,02	0,00		
FedEx	19,07	No	912,73	66,13	1.175,98	7,89	4,72	0,50	0,49		
FedEx	19,07	No	592,79	67,25	760,91	4,72	1,80	0,37	0,19		
FedEx	19,07	No	476,59	66,22	613,86	3,23	1,55	0,27	0,18		
CUTE STOCKHOLM	8,50	Yes (100%)	0,00	0,00	271,16	0,00	0,00	0,00	0,00	0,00	0,00
CUTE MADRID	99,30	No	0,00	0,00	3.429,81	0,00	0,00	0,00	0,00	0,00	0,00
CUTE LONDON	122,80	No	0,00	0,00	3.519,85	0,00	0,00	0,00	0,00	0,00	0,00
CUTE STUTTGART	99,30	No	0,00	0,00	2.631,90	0,00	0,00	0,00	0,00	0,00	0,00
CUTE AMSTERDAM	8,50	Yes (100%)	0,00	0,00	220,19	0,00	0,00	0,00	0,00	0,00	0,00
CUTE BARCELONA	32,37	Yes (50%)	0,00	0,00	1.063,70	0,00	0,00	0,00	0,00	0,00	0,00
CUTE HAMBURG	8,50	Yes (100%)	0,00	0,00	207,96	0,00	0,00	0,00	0,00	0,00	0,00
CUTE LUXEMBOURG	185,90	No	0,00	0,00	4.659,65	0,00	0,00	0,00	0,00	0,00	0,00
CUTE PORTO	185,90	No	0,00	0,00	7.022,92	0,00	0,00	0,00	0,00	0,00	0,00
NEW YORK CITY TRANSIT	19,07	No	1.148,29	43,65	1.650,04	0,66	0,01	0,08	0,19		
NEW YORK CITY TRANSIT	19,07	No	1.811,92	49,23	2.513,92	1,73	0,07	0,01	0,12		
NEW YORK CITY TRANSIT	13,36	No		0,00		1,17	1,32	1,18	0,12		
ELECTRIC BUS EVALUATION IN SEVILLE	56,24	No	0,00	0,00	76,33	0,00	0,00	0,00	0,00	0,00	0,00
ELECTRIC BUS EVALUATION IN SEVILLE (AC)	56,24	No	0,00	0,00	91,51	0,00	0,00	0,00	0,00	0,00	0,00
ELECTRIC BUS EVALUATION IN SEVILLE	14,20	No	447,26	59,44	554,10	59,47	76,46		1,91	13,81	
ZERO REGIO GERMANY	78,00	No	0,00	0,00	89,95	0,00	0,00	0,00	0,00	0,00	0,00
ZERO REGIO GERMANY	12,50	No	139,00	71,98	163,14						
ZERO REGIO ITALY	95,00	No	0,00	0,00	99,94	0,00	0,00	0,00	0,00	0,00	0,00
ZERO REGIO ITALY	12,50	No	113,00	71,65	132,71						
EMT BARCELONA	14,20	No	1.410,00	73,19	1.683,56	138,71			13,87		
EMT BARCELONA	-11,48	Yes (30%)	1.450,00	73,32	1.222,97						
EMT BARCELONA	14,20	No	1.060,00	73,36	1.265,17	78,02			10,40		
Mini E UNITED KINGDOM	120,80	No	0,00	0,00	52,19	0,00	0,00	0,00	0,00	0,00	0,00
Mini E LOS ANGELES	213,60	No	0,00	0,00	106,74	0,00	0,00	0,00	0,00	0,00	0,00
Mini E NEW YORK	213,60	No	0,00	0,00	106,74	0,00	0,00	0,00	0,00	0,00	0,00
Mini E BERLIN	120,80	No	0,00	0,00	52,19	0,00	0,00	0,00	0,00	0,00	0,00
Mini E MUNICH	120,80	No	0,00	0,00	52,19	0,00	0,00	0,00	0,00	0,00	0,00

Figure 3.40 Emissions sheet

3.2.7 Energy consumption

This group of data covers the following fields

- Well to tank (MJ/MJ fuel).
- Fuel from renewable source.
- Tank to wheel (MJ/ 100km).
- Well to wheel (MJ/ 100km).

For the final result of WTW energy consumption, the energy efficiency in the production of the fuel used has been determined

The WTW energy combines the WTT expended energy (excluding the energy content of the fuel itself) per unit energy content of the fuel with the TTW energy consumed by the vehicle per unit of distance covered, according to the following calculation:

$$\text{Total WTW energy (MJ/100 km)} = \text{TTW energy (MJf/100 km)} \times (1 + \text{WTT total expended energy (MJxt/MJf)})$$

Using the value of fuel economy, value of LHV for each fuel used the energy consumption is calculated for the section TTW.

The energy consumption values for the WTT section were calculated from data provided in the aforementioned documents. These documents are "WELL-TO-WHEELS ANALYSIS OF FUTURE AUTOMOTIVE FUELS AND POWERTRAINS IN THE EUROPEAN CONTEXT" version 2C, march 2007 of JRC y "Well-to-Wheels Analysis of Advanced Fuel / Vehicle Systems - A North American Study of Energy Use, Greenhouse Gas Emissions, and Criteria Pollutant Emissions", by General Motors. In particular were used data from Spanish Electrical Network (REE) and specific data from ZERO REGIO project.

When part of the fuel used comes from renewable energy sources, it applies the proportional part of reduction of emissions. For example, in the case of "EMT Barcelona 30% biodiesel", the 30% of fuel in volume is considered biodiesel (1.7 MJ/MJ_{fuel}) and the other 70% is considered diesel (1.16 MJ/MJ_{fuel}).

"Electric bus experience in Seville" shows the efficiency of electric motor compared with ICE.

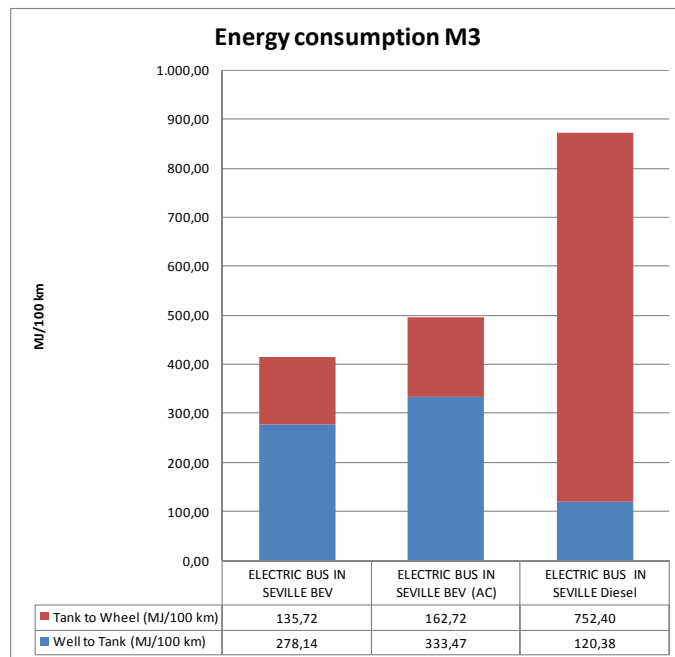

Figure 3.41 Energy consumption Minibus Seville

The figure 3.37 shows the influence of the climatology of city. The use of air conditional increases energy consumption by 19%.

The figure 3.38 shows the importance of the mode of fuel production in M3 vehicles category.

For project CUTE, the results are very different depending on the mode of production of hydrogen. In a first glance, hydrogen produced on-site consumes less energy than hydrogen produced in centrals and subsequent transport. This is the case of Hamburg or Amsterdam, in comparison with London or Porto. In the case of Barcelona, energetic consumption is higher due to grid electricity is used to produced hydrogen on-site.

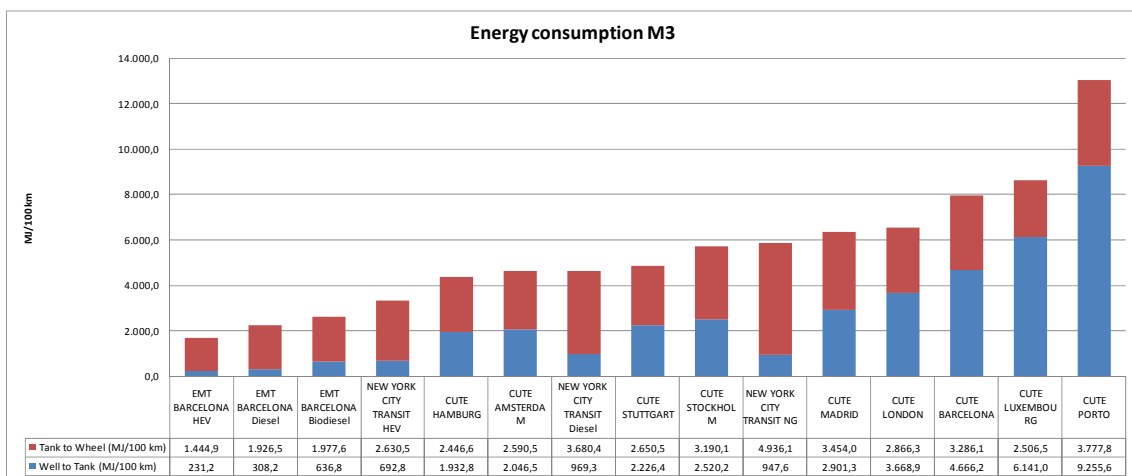

Figure 3.42 Energy consumption WtW M3

The graph shows how the hybridization of vehicles leads to a reduction in final energy consumption due to increase of fuel economy

For projects of category N2, the trend explained in emissions is similar in the analysis of energy consumption.

For UPS project, hybridization improves results in all circuits. For FedEx project the energy consumption of hybrid vehicles with gasoline motor is similar to diesel vehicles in the same circuit.

Only in the circuit with greater intensity kinetic results with HEV gasoline are more favorable than ICE diesel.

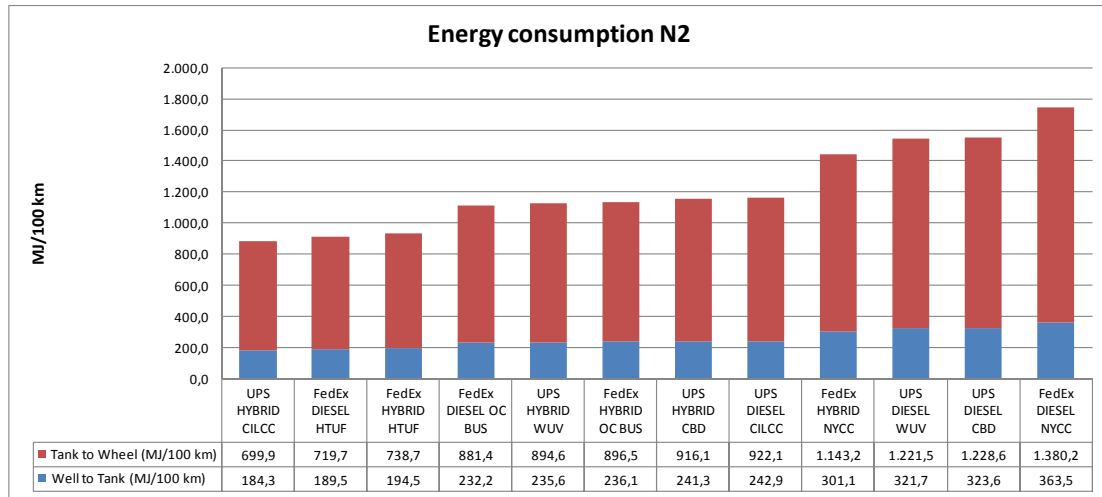

Figure 3.43 Energy consumption WtW N2

The figure 3.40 shows results for M1 Vehicle category.

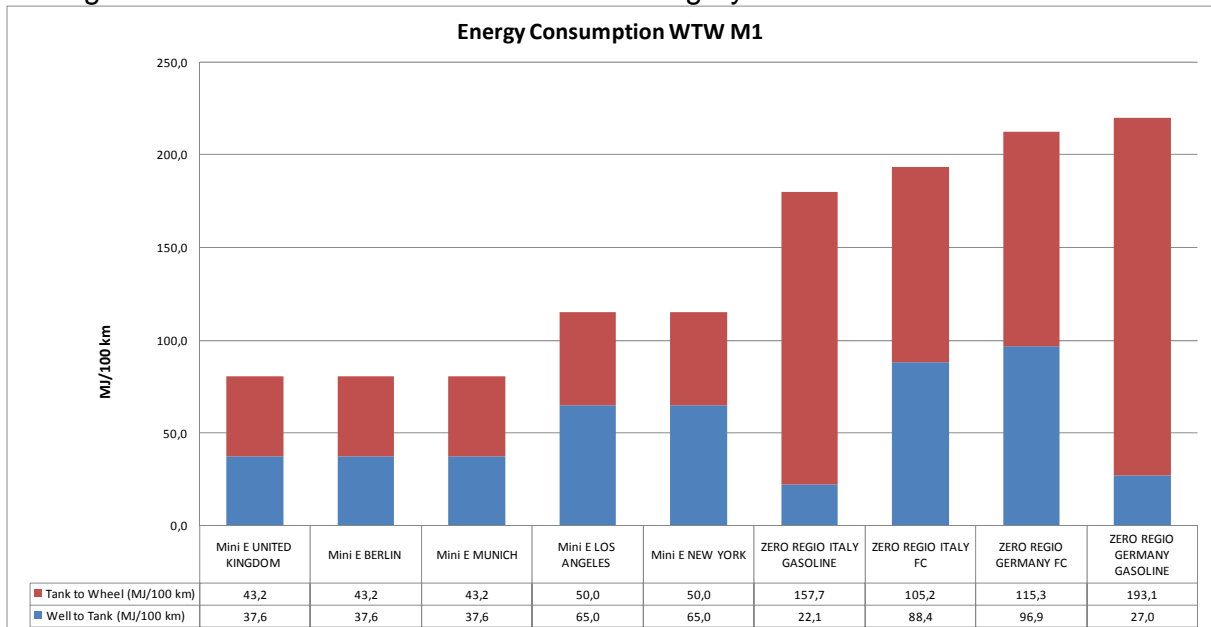

Figure 3.44 Energy consumption WtW M1

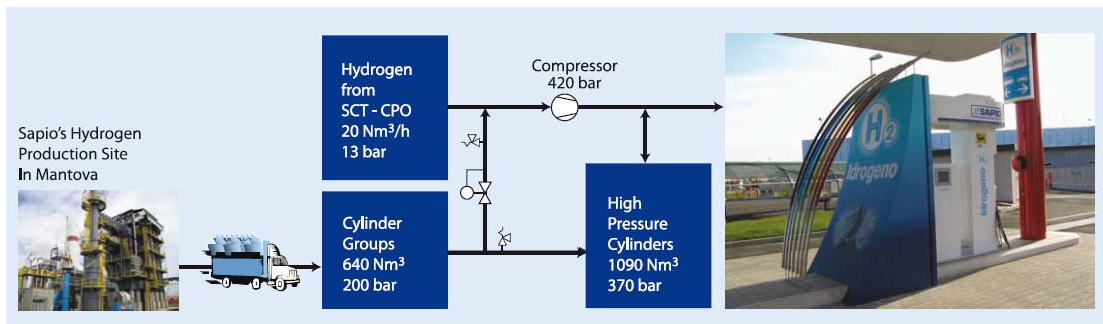

Figure 3.45 Complete refuelling system in Mantova, Italy

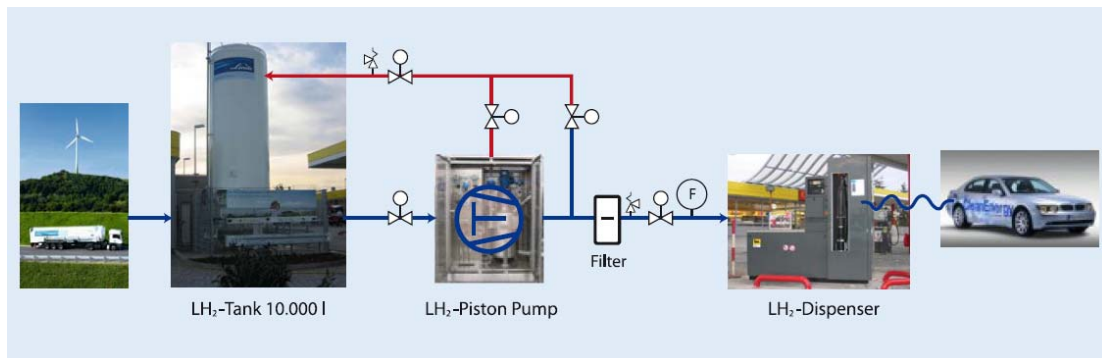

Figure 3.46 Complete refuelling system in Höchst, Germany

When production of hydrogen is not on site or with renewable energy, the energy consumption values are higher than with conventional fuels.

The high efficiency of a FCEV loses relevance due to energy inefficiency in production, compression, storage and transportation of H₂.

The energy consumption differences between European and American mini E projects are due to the higher percentage of renewable energy in the European energy mix.

Project	Energy consumption					
	Name	Well to Tank (MJ/MJ fuel)	Fuel from renewable source (Totally or Partially)	Well to Tank (MJ/100 km)	Tank to Wheel (MJ/100 km)	Well to Wheel (MJ/100 km)
UPS		1,26	No	184,33	699,87	884,19
UPS		1,26	No	235,62	894,61	1.130,22
UPS		1,26	No	241,28	916,09	1.157,37
UPS		1,26	No	242,87	922,13	1.165,00
UPS		1,26	No	321,70	1.221,45	1.543,16
UPS		1,26	No	323,58	1.228,61	1.552,19
FedEx		1,26	No	301,10	1.143,24	1.444,34
FedEx		1,26	No	236,12	896,52	1.132,64
FedEx		1,26	No	194,55	738,68	933,23
FedEx		1,26	No	363,50	1.380,16	1.743,66
FedEx		1,26	No	232,15	881,45	1.113,60
FedEx		1,26	No	189,54	719,67	909,22
CUTE STOCKHOLM		1,79	Yes (100%)	2.520,21	3.190,14	5.710,35
CUTE MADRID		1,84	No	2.901,35	3.453,98	6.355,33
CUTE LONDON		2,28	No	3.668,90	2.866,33	6.535,23
CUTE STUTT GART		1,84	No	2.226,38	2.650,45	4.876,83
CUTE AMSTERDAM		1,79	Yes (100%)	2.046,49	2.590,49	4.636,97
CUTE BARCELONA		2,42	Yes (50%)	4.666,24	3.286,08	7.952,32
CUTE HAMBURG		1,79	Yes (100%)	1.932,79	2.446,57	4.379,36
CUTE LUXEMBOURG		3,45	No	6.141,02	2.506,54	8.647,55
CUTE PORTO		3,45	No	9.255,60	3.777,80	13.033,39
NEW YORK CITY TRANSIT		1,26	No	692,82	2.630,53	3.323,35
NEW YORK CITY TRANSIT		1,26	No	969,33	3.680,44	4.649,77
NEW YORK CITY TRANSIT		1,19	No	947,59	4.936,11	5.883,71
ELECTRIC BUS EVALUATION IN SEVILLE		3,05	No	278,14	135,72	413,86
ELECTRIC BUS EVALUATION IN SEVILLE (AC)		3,05	No	333,47	162,72	496,19
ELECTRIC BUS EVALUATION IN SEVILLE		1,16	No	120,38	752,40	872,78
ZERO REGIO GERMANY		1,84	No	96,87	115,32	212,18
ZERO REGIO GERMANY		1,14	No	27,03	193,10	220,14
ZERO REGIO ITALY		1,84	No	88,37	105,20	193,57
ZERO REGIO ITALY		1,14	No	22,08	157,70	179,78
EMT BARCELONA		1,16	No	308,24	1.926,48	2.234,72
EMT BARCELONA		1,32	Yes (30%)	636,80	1.977,63	2.614,43
EMT BARCELONA		1,16	No	231,18	1.444,86	1.676,04
Mini E UNITED KINGDOM		1,87	No	37,58	43,20	80,78
Mini E LOS ANGELES		2,30	No	64,97	49,97	114,94
Mini E NEW YORK		2,30	No	64,97	49,97	114,94
Mini E BERLIN		1,87	No	37,58	43,20	80,78
Mini E MUNICH		1,87	No	37,58	43,20	80,78

Figure 3.47 Energy consumption sheet

3.2.8 Conclusions

The last available innovative technology is not always the “best option” in any case.

- *The importance of source of fuel and the way of production.*

WTW analysis emphasizes the importance of the source and mode of production of the fuel.

The mode of generation of fuel has great importance in the global balance of emissions and energy consumption.

The CO₂ emissions WTW and energy consumption WTW obtain different values depending on the method of fuel production in applications that use sustainable technologies.

Distributed generation of electricity from renewable energy sources and on-site production of fuel (i.e. hydrogen) minimizes CO₂ emissions and energy consumption compared with traditional modes of transport.

When the primary energy source to production of fuel is not renewable or production of fuel is not on-site, it causes that the high efficiency in the side TTW of new technologies has less relevancy due to energy inefficiency and CO₂ emission in the side WTT.

- *The technology in vehicles.*

A combustion engine uses only around a 30 % of the energy of fuel in practical applications, while the rest is lost in gases and in heat losses. An electrical motor has efficiency greater than 80 %.

Technological improvements in vehicles, such as hybridization, reduce emissions of CO₂ and energy consumption. When HEVs are driven in the electric mode, it is possible to obtain zero emissions. HEVs demonstrate improved fuel economy, compared with conventional ICE vehicles, and have a longer driving range than BEVs.

Hybridization yields better results for circuits where the average speed is between 35 and 45 km / h and the number of stops is high.

In these circumstances the time of operating of electric motor increases and regenerative braking decreases fuel consumption of vehicle. This leads to a reduction in WTW CO₂ emissions and energy consumption.

From a structural viewpoint, FCVs can be considered as a type of series hybrid vehicle, in which the fuel cell acts as an electrical generator that uses hydrogen. But final result, CO₂ emission and energy consumption, depend on the way hydrogen is produced. The high efficiency of electric motor of FCEV loses relevance when production of hydrogen is not on site or with renewable energy.

- *Influence of the typology of the city.*

The climate of the site influences the performance of the vehicle due to extreme temperatures. One example is the increased consumption of fuel by the use of auxiliary systems like air conditioning.

With regard to relief of the cities, fuel consumption increases as the height difference of route is higher. The higher fuel consumption causes an increase CO₂ emissions WTW and energy expended.

When cities have greater difference in height, HEV technology improves the efficiency due to the energy of regenerative braking and longer use the electric motor. Instead, FCEV technology reduces the performance in cities with large slopes.

This disadvantage is caused by a minimum current limitation set on the fuel cells. The minimum current limitation is implemented for reliability reasons and requires fuel cells to continue to produce electricity at minimum rate. In the practice this means that when driving FCEV downhill, vehicle still have a relatively high fuel consumption compared with ICE vehicle, which use virtually no fuel when decelerating and coasting.

3.2.9 Recommendations

This database intends to be a tool in order to help choosing the best option for the transport in a site. As shown in the conclusions, not always the best available technology has to be the best option.

The three first sheets of the database supply information on technology options and the last three offer a methodology to calculate CO₂ emissions and energy consumption, suitable to be used in new locations. This could make possible to determine the best available option for a particular emplacement.

First the location is analyzed in a comprehensive manner.

As shown, the mode of supply of fuel that will be used is very important. It is possible to use, for example FCEV being a very efficient technology and environmentally friendly but if hydrogen production is inefficient TTW benefits are diluted by high energy costs and emissions WTT.

In order to select the best option is necessary to perform a WTW analysis as particularized as possible.

The database is sufficiently versatile and each process is identified to modify general parameters for particular values.

Values of energy consumption and CO₂ emission WTT, fuel consumption and fuel storage are used.

The combination of these parameters provides the information necessary to help decide the best option.

In the background are the climatic and orographic features of the site. There is evidence that both relief as extreme ambient temperatures conditions affect the economic fuel, therefore they have be taken into consideration.

To determine this influence should characterize our site and identify those that are in the database with similar characteristics. Then the experiences in them can be studied and the different technology options for selection ca be filtered.

The global study of the various factors in the ITACA database that influence in final values of CO₂ emissions and energy consumption ensure a better approach to the

final goal of the project, looking for the best sustainable transportation option.

3.3 Showcases and Good Practices

In addition to the database previously described, the main contribution of the ITACA project has been the identification and sharing of best practices, showcases and “flagship” projects in the ITACA regions, with the intention of increasing the common knowledge in the field for the benefit of future policies and mobility plans. Many of these examples have involved innovative technologies. ITACA partners’ contributions to the Innovative Technologies area fit into three main topics:

- Use of new propulsion systems in vehicles (battery-electric vehicles, fuel cell electric vehicles and hybrid-electric vehicles, etc.), with five showcases/good practices identified.
- Use of renewable energies and low carbon eco-friendly fuels (hydrogen from R.E., mix of hydrogen and methane, electricity from R.E., biogas, etc.), with four showcases/good practices identified.
- Use of Intelligent Transport Systems and ICT applications for CO2 saving (fare and ticketing integration systems, congestion taxes, etc.) with five showcases/good practices identified.

3.3.1 New propulsion systems

Regarding the deployment of new vehicle propulsion systems, after a preliminary inventory of available technologies, the ITACA experiences provided here have focused on hybrid-electric vehicles, battery-electric vehicles, and fuel cell electric vehicles. Their status of development in each ITACA region is different, but there are some common points:

- Hybrid-electric vehicles (HEVs) are considered a mature technology with a great potential of market growth in the short-term, not only in the individual user market, but also within sectors such as taxi companies and fleets. In this context, public grants for the acquisition of hybrid vehicles, ideally through a simplified application procedure, have been demonstrated to have great success, for example in the Andalucía region of Spain. Over time, plug-in hybrid vehicles should help pave the way to battery-electric vehicles.
- Battery-electric vehicles (BEVs) are expected to play an increasingly fundamental role in urban mobility. After several unsuccessful attempts, it seems that, this time, the battery-electric car is here to stay in our cities. Commonly named “electric vehicles,” these are more accurately called pure batteries-electric vehicles, because there are in fact different types of

electric vehicles, including HEVs above, and the most efficient type, grid-connected vehicles (GCVs), which require no stored power, as discussed in Chapter 3. All the ITACA regions have contributed with experiences and initiatives for BEVs, covering a wide field of applications: from cases focused on the urban use of the vehicle (e.g., battery-electric taxis in Utrecht; battery-electric car sharing in Seville; municipal vehicles in Lidingö as designate in their Environmental Plan; regional and local administration fleets in Bologna; and more) to touristic uses of BEVs (e.g., battery-electric tourist shuttles in Huelva; or the promotion of battery-electric vehicles targeted to the tourist industry in Rimini, in the framework of the mobility scheme, "Mi nuovo elettrico"). The benefits of BEVs for CO₂ emissions and in some cases, for local urban emissions, are increased when the electricity used is, totally or partially, produced from renewable energy sources. It is important that the good practices and showcases provided by our ITACA partners are focused not on individual drivers, but on public transport and institutional fleets, who appear to be the primary early-adopters of this technology.

- Fuel cell vehicles (FEVs) are yet another type of electric vehicle, but where the electricity to power the motor is produced on-board from hydrogen in a fuel cell. The fuel cell is powered by filling the fuel tank with hydrogen. Hydrogen producing electricity represents one of the most promising ways to realise sustainable transportation energy. There is no real controversy between battery and fuel cell vehicles: Battery and fuel cell technologies are perfectly complementary as they regard different drive train applications. Fuel cells, as an efficient conversion technology, and hydrogen, as a clean energy carrier, have great potential to contribute solutions to Europe's energy challenges. A number of demonstration projects have been carried out across Europe to demonstrate the feasibility and reliability of the technology under real world conditions, taking into account not only technical and economic issues, but also public acceptance, training and education; with the final goal that hydrogen and fuel cell road vehicles will meet challenging performance, durability, safety and cost targets by 2015, and anticipating mass-market rollout in 2020. ITACA regions have participated in some of these projects focused on the research, development and demonstration of fuel cell vehicles for road transportation. Among these projects, of particular interest is the CUTE project in Stockholm, focused on the testing and operation of fuel cell buses in daily public service; and the Spanish project Hércules in Andalucía, focused on the design, construction and testing of a fuel cell vehicle based on a commercial light sport utility vehicle (SUV).

All the compiled best practices and showcases are included in Annex I, but the following summaries offer a more detailed explanation of some representative cases, ordered by technologies and selected due their potential to be transferred and implemented in different regions:

Hybrid vehicles:

Use of hybrid vehicles in the public transport sector, mainly for taxis, is a common and well adopted way to reduce CO₂ emissions in regions like Stockholm, but only in the last three years has it become a success in Andalucía. Public grants for the purchase of such HEVs with a very simple application procedure made the difference. This approach has been positive for the progressive implantation of an innovative technology in a very conservative sector, demonstrating the advantages in some cases of “soft” measures. Other examples are not so successful, like, for example, the city of New York, where the local government tried to force the acquisition and use of hybrid vehicles in the new taxis, without the general support of taxi drivers. Recently, this attempt to force the city’s taxi owners to switch from fossil fuel guzzlers to hybrid vehicles was rejected by a federal appeals court.

Particular users and companies located in Andalucía can now buy a hybrid car using a simple procedure which requires no formalities with the administrative offices. People only need to visit one of the dealers participating in the programme, where they can find the available hybrid models in the market. The dealer, through an electronic procedure, will submit on behalf of the final user the funding request to the Energy Development Programme of the Agencia Andaluza de la Energía. The user will receive the equivalent discount on his invoice directly and no other step with the Administration is needed.

In the framework of this programme, the Regional Government, through the Agencia Andaluza de la Energía, has funded the acquisition of 1,694 vehicles with hybrid technology since 2008. The total budget of these grants has achieved 4.8 million Euros, with an impact in the economic activity of sector higher than 35 million Euros. One of the main targets of this programme is the taxi sector. In this context, the grant, and the fuel savings associated with hybrid technology in comparison with conventional taxis, has helped more than 335 taxi drivers to choose hybrid vehicles, increasing the trust of Andalusian taxi drivers in this technology, with an overall grant of nearly one million Euros, almost the 20% of total budget for the programme.

In Seville for example, the success of the programme has been important because in only three years, the number of hybrid taxis has been increased from a negligible percentage to a substantial 8%, with similar results in other Andalusian cities.

The low carbon contribution is clear: for a taxi driver, running 80,000 kilometres per year mostly in urban areas, it is possible to achieve with this technology a fuel savings of 1,808 litres per year, saving the emission to the atmosphere of more than 4.16 tonnes of CO₂ annually. For the 1,694 vehicles mentioned, that is 1,965 tonnes saved per year by the programme. In terms of programme cost, it was 2,443 euro per tonne, for the first year – if the vehicle lasts ten years, the average cost would be 243 euro per tonne saved.

The taxi drivers association and individual users have suggested some additional measures to improve the impact and diffusion of the initiative:

- It is necessary to include in the programme information campaigns about hybrid technology, focused on particular sectors or targets, like taxi drivers: benefits, advantages, potential disadvantages, technical differences in comparison with conventional technologies, etc.
- The regional programme has to be complemented by local benefits, like the reduction of municipal taxes, low prices parking, etc.
- To offer information to customers about the benefits of use of hybrid taxis in terms of CO2 saving, so the client could prefer a low carbon emissions / hybrid vehicle when a taxi is requested.

Battery-Electric vehicles:

GreenCab is a large scale experience with clean, electric mobility in the taxi sector. Launched in the city and region of Utrecht by a private company, Prestige GreenCab has developed in close collaboration with a wide range of private and government partners. Apart from being a 'normal' taxi company using battery-electric vehicles, the goal of GreenCab is to be a test site to promote practical application of sustainable mobility technologies. This real-life situation provides knowledge and insight on behavioural, technical, administrative and political effects. This reveals which innovations are promising for large-scale production. In addition, the test site aims to promote the supply of certain modes of transport, such as plug-in hybrid as well as battery-electric vehicles.

The service began with 6 battery-electric cabs, by the end of 2011 this will increase to 40. The project receives a government's grant from the 'test site' programme for battery-electric and hybrid-electric vehicles. Budget of this programme is € 10 million.

Another experience with clean and electric mobility in urban areas is the COCHELE service. This initiative, promoted by a private company, is a battery-electric car-sharing service in which the user has at her or his disposal a network of vehicles, which can be reserved and used as needed. Seville was thus the first Spanish city to implement a car-sharing service with battery-electric cars, complementing various mobility options already available in the city. COCHELE service members can book online 24 hours a day and thus use any of the cars located in the pickup and delivery points strategically located in commercial, residential and office areas of the city and its metropolitan area. An important benefit of the service is that battery-electric cars are allowed access to the historical center of Seville without time restrictions, and there is free parking for these vehicles. The service is targeted to people who occasionally need a vehicle for their urban trips. In fact, this particular user will benefit from considerable cost savings compared with private car ownership. The service fees include the fixed costs of the fleet: insurance, taxes, maintenance and servicing, cleaning, parking at

the corresponding point, and so on. The remaining costs are derived from actual use of vehicle time and mileage. At present, the monthly fee is 19.95 Euros, the cost of the hour is 4.5 Euros, and the cost of the mileage is 0.29 Euros/Km.

A similar experience is being implemented in the Paris metropolitan area (Autolib). The key items of this service will be:

- High Density Network : 1200 stations (1 Station / 400 meters)
- 24h/7 days service
- Internet, Mobile and street hot points to subscribe, reserve...
- Guaranteed parking place at destination (if reserved)
- Cruise assistance (GPS) & emergency
- Temporary stops not billed (15min)
- Priced with moderation for a large public usage (12€/month + 15cts/min)
- Young drivers accepted with no surcharge
- Recharge allowed to private vehicles

Fuel cell vehicles:

The Spanish “Hércules” project is one of the most interesting projects developed in ITACA regions in the area of hydrogen technologies and fuel cells, because it has been structured around a dual purpose: to demonstrate the technical and economic feasibility of hydrogen production from renewable solar energy; and to validate the use of hydrogen in fuel cells in the automotive sector. To achieve these goals the cooperation of different companies and research groups has been needed, particularly to bring together specialists in each of the technology areas that are addressed in the project. The project started in January 2006 and finished officially in 2010, but, due to their interest, some partners continue working on the improvement of the prototypes and deliverables of the project. Total budget of the project was around 7 million Euros.

One of the Hércules subprojects was devoted to integrating new technologies in the automotive sector, improving energy efficiency and providing environmental benefits. The objective was to use to advance the development of alternative fuels automobiles able to operate with greater power efficiency than conventional vehicles.

To achieve these objectives, the conventional powertrain of a commercial vehicle was replaced with a new power system consisting of a fuel cell stack fed with pure hydrogen and an electric motor. The platform used for the project is a commercial, light-duty, 4x4 vehicle that uses compressed hydrogen as the fuel for a solid polymer fuel cell stack. The vehicle’s main characteristics are as follows:

- Light-duty 4x4 vehicle (Santana 350).
- Hybrid configuration fuel cell/batteries.

- Vehicle autonomy higher than 100 km.
- High efficiency electric powertrain, including regenerative braking to recover energy lost during braking.
- Reasonable cost together with economies of scale for future mass-produced components.
- Safe vehicle, able to fulfil all the existing safety standards and tests for this type of vehicle.

The most important lesson learned was that hydrogen can be used in a practical and safe way as a fuel for vehicles. Further technical and economic improvements must be achieved before the results would be competitive in cost and performance with current fossil fuel technologies. Nevertheless, some partners are using the platforms developed in the project to test new products and designs with applications in the hybrid and pure battery-electric vehicles markets in the short and medium term.



Figure 3.48 (Source: INTA/Hércules Project)

3.3.2 Low-carbon fuels and renewable energies in the urban transport

All the ITACA regions have experiences in the use of low-carbon fuels for internal combustion engines. Natural gas is widely implemented in public buses in several cities. Liquefied petroleum gas (LPG) is also used in public transport, mainly in the taxi sector. Although their use reduces the emissions of CO₂ in comparison with diesel and gasoline vehicles, these emissions are yet significant and they are still fossil fuels, with the environmental, security and supply problems associated with oil. The use of renewable energies, in particular biogas, could help to solve both challenges, giving more options for fuel production, even at the local level, and

saving CO₂ emissions when natural gas is totally or partially substituted by biogas. Additionally, the development and introduction of new propulsion systems for urban transport includes the use of alternative fuels (or energy carriers), like electricity and hydrogen. These energy carriers can be produced from fossil fuels or renewable energies. Obviously, local CO₂ emissions are zero when either energy carrier is used, but the real CO₂ emissions have to be evaluated using a suitable Well to Wheel analysis (WtW), which analyses emissions and energy consumption over the entire chain, from the production of the fuel to the end-use phase. Showcases and best practices proposed by ITACA partners cover three main types of innovative applications of low-carbon fuels and renewable energy.

3.3.2.1 Use of low-carbon fuels in methane and internal combustion engine buses:

This topic comprises the well established use of biogas in the buses of the Stockholm, Sweden public transport system; and a demonstration project about the use of hydrogen-methane blends for public city transport bus in the Emilia-Romagna region of Italy.

Biogas is generated by digesting organic material. In the generation of biogas by anaerobic digestion, a wide range of biomass types can be used as substrates. The most common biomass categories used in European biogas production are animal manure and slurry, agricultural residues and by-products, digestible organic wastes from the food and agro-industries, organic fraction of municipal waste (vegetable and animal origins), sewage sludge, and dedicated energy crops. Landfill gas may also be collected for biogas. Typical CH₄ content in biogas varies from 53-70 % vol. (digested) to 35-65 % vol. (landfill). The other main components are CO₂ and H₂O, with a minor presence of other substances including NH₃, and H₂S.

Biogas has many energy utilizations, depending on the content of the biogas and the local demands. Generally, biogas can be used for heat production by direct combustion, electricity production by engines or micro-turbines, CHP generation when both heat and energy are needed, or as a vehicle fuel. The main European biogas producers are the U.K. and Germany, where they use it for power generation. Sweden is a leader in biogas as a vehicle fuel, where a large share of the biogas produced is upgraded and used in vehicles. In fact, in Stockholm, the development of biogas has matured significantly over the past decade, and production is operating at industrial scales, with demand growing larger still. This development has been driven to a large extent by Stockholm's public transit company, which runs a significant portion of its fleet on biogas and is recognized as a leader in the development of biogas buses, currently instructing other cities in its experiences and lessons stemming from the Stockholm biogas bus project.



Figure 3.49 (Source: Stockholm Public Transport, SL)

In this context, the city of Lidingö has proposed a replicable good practice to increase the use of biogas widely in metropolitan areas, based on the experience in Swedish municipalities. In this case, both the regional wastewater companies and the regional recycling and waste management companies are owned by the municipalities in the Stockholm region, and each municipality manages entrepreneurs that collect the waste in the municipality.

This means that the municipalities can act for an increase in biogas use both with supply and demand management. The demand for biogas is growing and several of Stockholm's buses, taxis and private cars are run on biogas. A biogas bus has low emissions and is quieter than a diesel bus. Emissions of nitrogen oxides and particulate matter are significantly lower than for a diesel bus. Biogas adds no additional carbon to the atmosphere as it is a substitution in the natural carbon cycle. Stockholm Public Transport (SL) is Sweden's leading provider of public transport services. On a normal weekday more than 700.000 Stockholmers use their service.

One of SL's goals is to provide a 100% fossil free public transport not later than 2025. Today, all track vehicles run on green energy and the number of renewably-fuelled buses is increasing steadily. SL has used biogas-fuelled buses in the inner city services since 2003.

The city of Lidingö has ensured through a variety of measures that SL buses on Lidingö will run on biogas. As one of the owners of the waste water company, and with the sewage plant situated on the island, Lidingö has facilitated the delivering of the gas to the SL depots. As a landowner, Lidingö has also offered SL a place for a depot on the island.

An example of demand management is public procurement. The city of Lidingö purchased the garbage collection business in 2008/2009 (start 2010) with a demand for biogas trucks. There is a lack of biogas refuelling stations in the region. An example of the close relation between the municipal demand and supply management is the biogas station built in 2009 at a waste plant south of Stockholm, in Hagby. The station was a result of the demands for garbage collection with biogas trucks by many municipalities. Later this station was also opened to the public.

As an additional benefit, the use of biogas in vehicles helps reduce the expense and pollution connected with waste management as an alternative to incineration and/or depositing. This is a perfect example of symbiosis, helping to close the loop between human waste and public transportation and giving response simultaneously to two of the main questions for many large cities: How to manage an increasing amount of waste generated by growing populations and how to reduce pollution stemming from public transportation? The primary barrier is economic.

According to Stockholm Public Transport (SL), the cost comparison per km for different fuels in buses running in the inner-city of Stockholm is as follows (April 2008):

Cost SEK/Km	Diesel	Biogas	Ethanol
Fuel consumption	0,63	0,92	1,20
Fuel cost	6,65	6,13	7,44
Bus investment	3,75	3,88	3,59
Distribution	0,02	0,75	0,06
Service	0,77	1,32	1,05
SEK/km	11,19	12,08	12,14
%	---	+8 %	+8 %

Table 3.4. Source SL

Although diesel was more price-competitive at that time, the volatility of oil prices and long term potential price rise, coupled with potential cost savings in the biogas sector over time, means diesel price can easily be higher than biogas. Moreover, the relative externalities for biogas are much more attractive than for diesel.

At present, biogas is less efficient in terms of energy unit per km than diesel and slightly more expensive, but again on the plus side, biogas is carbon-neutral which in itself is a money saver, as CO₂ emissions are now being measured and CO₂ per

unit emitted is being taxed or attached penalty fees in many cities/countries due to stricter environmental regulations.

In fact, the CO₂ emissions for different fuels in buses, using a WtW analysis, shows significant differences, as estimated by the Baltic Biogas Bus project:

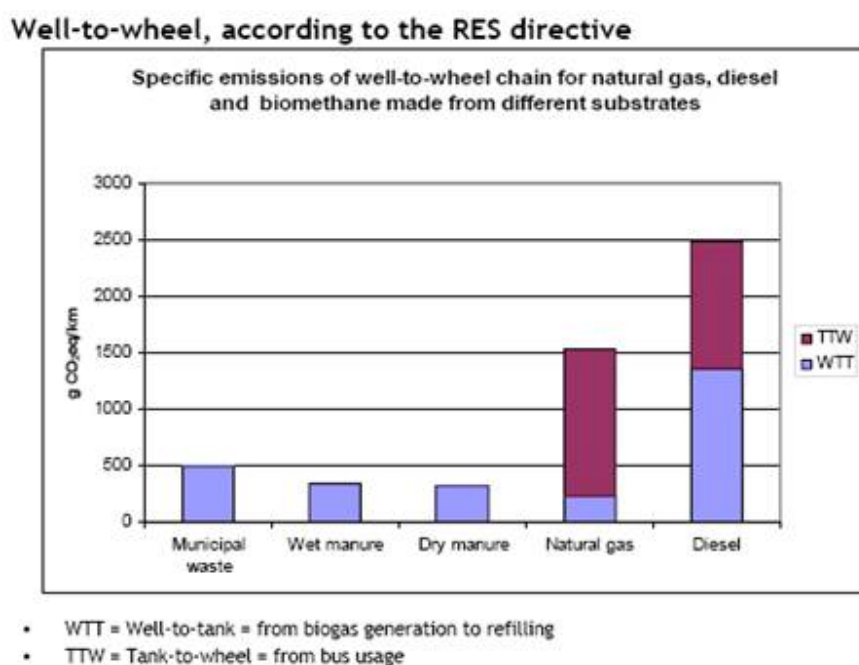

Figure 3.49 (Source: BalticBiogasBus Project)

Summarizing the results for Stockholm using renewable fuels: SL has 660 ethanol and 159 biogas buses in operation, as well as “5% FAME -fatty acid methyl ester-” in the standard diesel in 1250 buses. In total, this produces an estimated reduction of more than 20 million litres/ year in diesel consumption, and a reduction of CO₂ emissions amounting to more than 70,000 metric tonnes per year, as well as a strong reduction of PM and NO_x emissions.

3.3.2.2 HCNG: Combining hydrogen with natural gas

Another interesting demonstration of gaseous fuel based on methane with a high potential for CO₂ reduction is the experience carried out in the Emilia-Romagna Region (ERR) regarding the use of hydrogen-methane blends in public transport buses.

The Hydro-Methane (IDROMETANO) project set out with the primary objective of helping to reduce the environmental impact of the public transport sector (in terms of CO₂ and air pollutant emissions) through the use of a gaseous fuel blend up to 20% hydrogen and 80% natural gas, by volume (in short, “hydro-methane”, or HCNG). The vehicles used were a CNG 8-meter bus (ATM) and a CNG-12 meter

bus (ATR). In 2008, the Emilia-Romagna Region purchased the ATM and ATR buses for 200.000 € each, in order to test hydromethane fuel in a private circuit.



Figure 3.50 IDROMETANO test bus

The road tests were conducted on a circuit located within the ENEA Research Center, Casaccia, that is similar to the typical path of a city bus line. It is 3.8 km long with an altitude ranging between 132-152 meters above sea level, with alternating uphill and downhill sections. The reduction of fuel consumption, in comparison with the use of pure methane, varies in a range between 4% and 15%, according to the variation of the fraction of hydrogen in the mixture. The reduction of fuel consumption is attributable to the improved performance of the engine thanks to the positive effect of a higher burn rate of hydrogen added to natural gas.

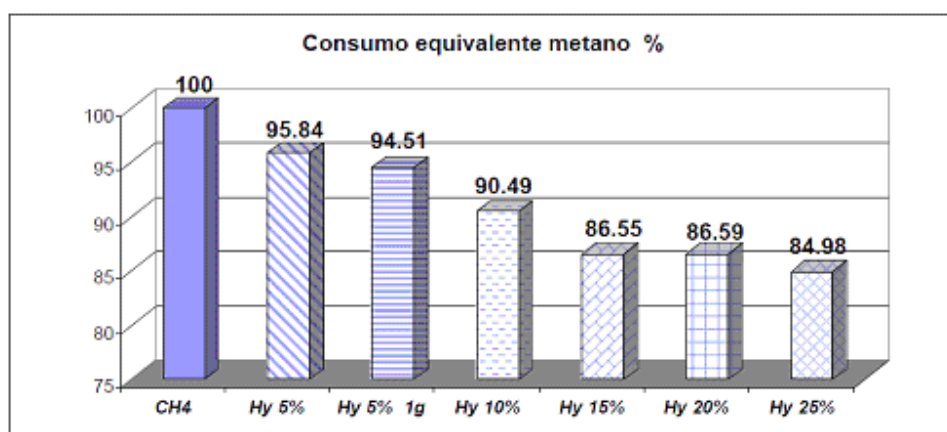

Figure 3.51 (Source: Emilia-Romagna Region)

The CO2 emissions for an 8-meter bus, comparing to CNG (in %), are as follows:

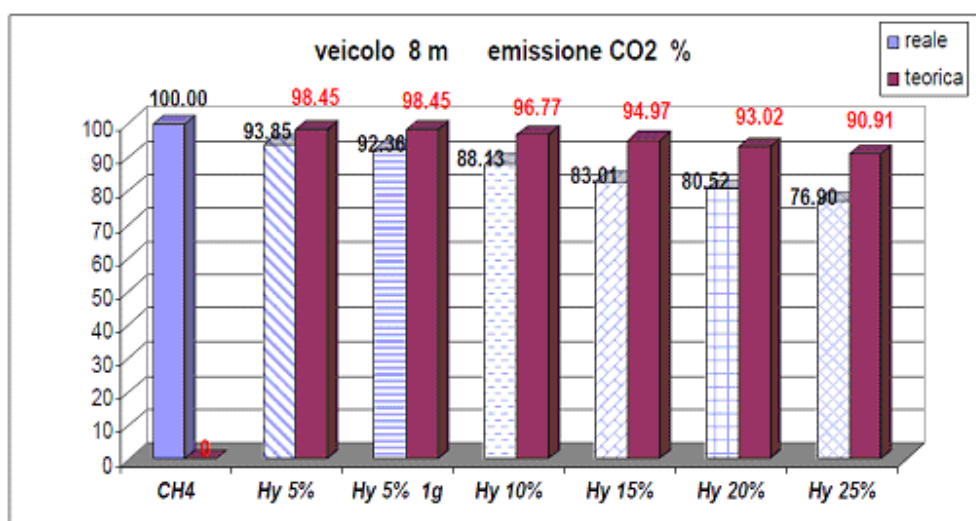

Figure 3.52 (Source: Emilia-Romagna Region)

The following table shows the data measured in CO2 emissions, for 8-m and 12-m buses:

CO2 emissions - g / km				
	8 m		12 m	
	CO2 g/km	kgCO2/kg mixture	CO2 g/km	kgCO2/kg mixture
CH4	833.32	2.71	1032.46	2.71
Hy 5%	782.06	2.67	950.75	2.70
Hy 5% 1g	769.68	2.69		
Hy 10%	734.44	2.65		
Hy 15%	691.75	2.65		
Hy 20%	671.00	2.62		
Hy 25%	640.86	2.60		

Table 3.5. (Source: ENEA)

From the surveys performed, the actual reduction is beyond the theoretical one expected for the simple reduction of the carbon atoms with hydrogen atoms. This essentially occurs as a leverage effect happens, able to amplify the reduction in CO₂ emissions beyond the theoretical limit. The increase of the reduction is attributed to the improved fuel efficiency that reduces energy consumption, and therefore the emission of combustion products. The leverage effect observed is between 3 to 5 times the expected theoretical value, calculated with the assumption of invariance of engine performance. The mixture of 25% produces a 25% reduction in CO₂ emissions compared with theoretical 9% expected and is the largest absolute reduction detected. In relative terms, compared to the theoretical reduction, the 5% blend coupled with the delay of 1° (1 g) of the ignition advance, is the one that has the strongest leverage.

The IDROMETANO project has not only shown a positive use of hydrogen mixed with methane (HCNG), but also highlighted some technological aspects for the best use of methane-hydrogen mixtures in normal commercial applications.

In urban driving HCNG showed a positive trend of energy performance. There is a higher energy efficiency of the mixtures proportional to hydrogen content. The prospect of reducing CO₂ emissions is one of the strengths for the use of mixtures of hydrogen and methane. There is a “leverage effect” that can amplify the reduction in CO₂ emissions beyond the theoretical limit.

The CO emissions are very low. The measurements are at the limit of instrument sensitivity and no measures have shown CO below the limits imposed by the European standards and in particular for the class EEV. In the Casaccia urban circuit tests, NO_x emissions were reduced up to 47% using the 5% hydrogen mixture. Similar values are also obtained with hydrogen mixtures of 10% and 15%.

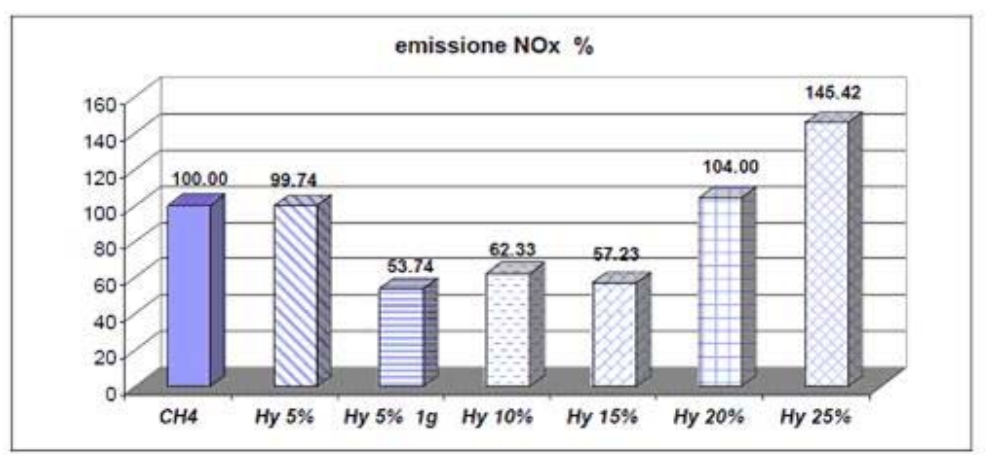

Figure 3.53. (Source: Emilia-Romagna Region)

A very noteworthy caution emerges, that higher percentages of hydrogen were found to actually increase NO_x emissions substantially, 4% for the 20% mixture and over 45% for the 25% hydrogen mixture.

The technical interventions on the 8 meter bus were limited; for more details about the testing of the buses, see Annex III.1.6 (*Internal combustion engine with biogas, natural gas and mixtures with hydrogen*).

In 2006, ERR demonstrated through a study carried out by ENEA that the 15% mix of hydrogen with 85% natural gas significantly reduced CO₂ and atmospheric pollutants emissions. Furthermore, with these percentages, the overall energy balance of the system – including the hydrogen production through the steam reforming process – is comparable to the same vehicle fuelled with natural gas.

In 2009, ERR took part as coordinator in the EU LIFE+ project called MHYBUS (through 2011). The project also studies a methane/hydrogen blend, specifically to circulate a bus in the city-center of Ravenna. The main specific objectives of the project are:

- To implement the initial steps – in term of studies, technical activities, costs, and administration – necessary to lead to a first prototype of a hydro-methane bus.
- To provide a solid base for the implementation of air quality and climate change policy measures at the regional level.
- To increase the ERR citizens' awareness in relation to climate change and air quality issues by exploiting the demonstrative potential of the prototype.

The goal is the successful prototype will serve as leverage to initiate a virtuous cycle toward the widespread use of hydro-methane by public transport utilities in the region and beyond.

Similar results were obtained in the Swedish city of Malmö, where two buses of the local bus fleet have tested CNG mixed with 8 % hydrogen (by volume) as fuel for over a year, without any modifications to the lean-burn CNG engines. The Lund Institute of Technology at Lund University, Sweden, has confirmed significant improvements in fuel efficiency, more stable operation of the engine and reduction of emissions of the test buses, through bench testing of the engines. Measurements of efficiency, emissions, combustion variations, knocking, and more have been performed under a variety of test conditions.

As in the IDROMETANO example, the increase in efficiency, together with the reduction of the carbon content of the fuel, decreased the emissions of CO₂ substantially with the use of hydrogen as a fuel additive. Lower emissions of HC and CO are then achieved, as the combustion is more efficient, and with proper equipment, NO_x values can also be reduced.

Further tests with a 20% hydrogen mix have been performed in the laboratory. These tests show significant improvements. The reduced combustion duration increases the efficiency substantially and as discussed earlier, enables the reduction of NO_x emissions when using a higher air/flow ratio combined with

optimised ignition timing by using a higher air/fuel ratio and/or less spark advance (see III.1.6 Internal combustion engine with biogas, natural gas and mixtures with hydrogen).

The reduction of CO₂ emissions is again substantial.

The buses could thus still use CNG as fuel if needed. The heavier mixture with 20 % hydrogen in the CNG was tested in a bus which has required modifications of the mapping of the engine both for ignition and the air/fuel ratio.

3.3.2.3 *Use of “green” electricity to power electric vehicles.*

It is a given that CO₂ emissions in battery-electric vehicles are dependent on the way the electricity is produced. If a Well to Wheel analysis is done, a hybrid-electric vehicle might even have lesser CO₂ emissions than a battery-electric vehicle if coal, without CO₂ capture, is used for power generation. In consequence, as far as more renewable energy is used for such generation, lower CO₂ emissions will be produced.

In the GreenCab described previously, the city of Utrecht will build 300 charging points, from now until 2013, all 100% green electricity.

Even when using the grid to recharge a battery-electric vehicle, if renewable energies are a large enough part of the energy portfolio, the use of BEVs can reduce CO₂ emissions. In Spain, for example, the contribution of renewable energies in 2010 reached 35%: more than gas and coal-fired output combined. (Wind generation increased its share of total coverage to 16% of demand, with 2% contributed by solar energy.)

On several occasions, maximum instantaneous hourly and daily wind outputs were exceeded, achieving up to 14,962 MW of instantaneous power, and 315,258 MWh of daily output, representing 43% of electricity demand that day. Similar scenarios have been achieved in other European countries. In this context, battery-electric cars might even be used for distributed renewable energy storage, which is a key missing ingredient for increasing the share of renewable energy. The potential synergy is very promising. Efficiency losses in charging and discharging must be taken into account, as well as the line losses which may be partially avoided thanks to decentralization. Particularly for intermittent renewables like wind, reducing gaps between peaks and off-peaks with storage increases their maximum potential share of the grid mix to meet conventional usage demands for 24-hour power availability.

3.3.2.4 Use of hydrogen produced from renewable energy in fuel cell vehicles

The previously described Hércules project in Andalucía, regarding the hydrogen production from solar energy to refuel the fuel cell vehicle, is the primary ITACA example for this topic.

The main objectives for this task in the project were:

- to demonstrate the viability of making hydrogen from renewable energy
- to generate a new technological market improving the Industrial knowledge in this area
- to improve the feasibility of developing a network of hydrogen filling stations in Spain
- to test an alkaline electrolyser (PEM) to compare with other electrolysers
- to compare different solar technologies integrated into the plant, to supply electricity to the electrolyser
- to optimize the electrical integration between the solar energy and the electrolyser

The following diagram shows the main components of the facility:

- Solar plant
- Electrolyzer
- Hydrogen purifier
- High pressure hydrogen storage system
- Hydrogen dispenser
- Auxiliary systems (cooling, water supply, compressed air supply, control and data acquisition systems, safety, etc.)

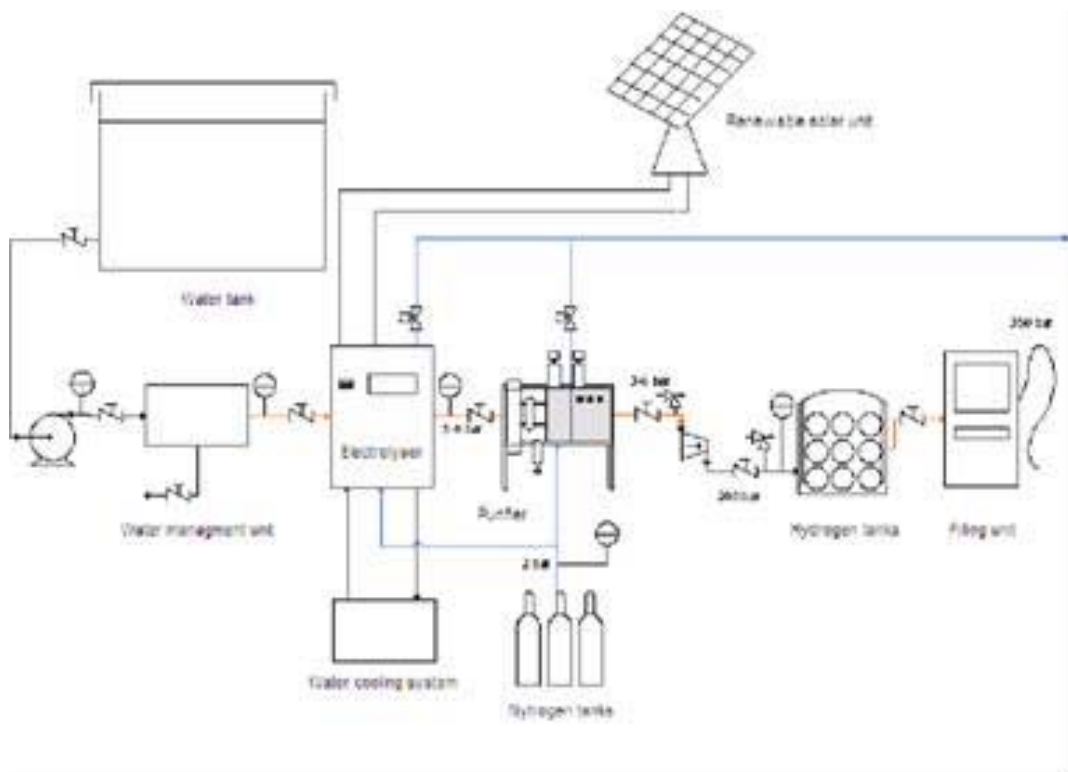

Figure 3.54. (Source: Hynergreen/Hércules Project)

The main characteristics of the solar plant are:

- Whole electric power 65.6 kW
- Photovoltaic field in two axis tracking: 18.6 kW
- Photovoltaic field in fixed structures: 22 kW
- Concentration PV panels: 15 kW
- Stirling Dish: 10 kW



Figure 3.55. (Source: Hynergreen/Hercules Project)

The main characteristics of the electrolyser are:

- Max. H₂ produced: 12.5 Nm³/h
- Continuous H₂ produced 10 Nm³/h
- H₂ out pressure: 4 – 6 barg
- Max. power: 67 kW
- Max. consumed: 10 l/h



Figure 3.56. Hydrogen fueling station. (Source: Hércules Project)

The main lesson has been that hydrogen can be used in a practical and safe way as a fuel for vehicles. Hydrogen production, as with BEVs, may also be used as a carrier to store electricity produced from intermittent renewable energy sources such as solar, here, or wind, when the instant power is too large to be injected into the grid.

Further technical and economic improvements must be done before hydrogen will be competitive in cost and performance with current fossil fuel technologies. Regarding the hydrogen station, an additional problem has been the lack of legislation and track records with such facilities, so a daunting license management procedure was needed to build and start up the hydrogen filling station, with a negative impact on the planning and execution of the project. On the plus side, some technical problems have been solved to optimize the electrical and control integration between the solar plant and the electrolyser.

3.3.3 Intelligent Transport Systems (ITS)/Information and Communication Technologies (ICT) for CO2 reduction

Information and Communication Technologies (ICT) are critical to improve the competitiveness of European industry and to meet the demands of its society and economy. ICT can contribute strongly to delivering a sustainable, low carbon society and help progress towards the Europe 2020 targets on climate and energy. ICT can assist in reshaping the demand side of our energy-dependant society, reducing energy consumption, and subsequently CO2 emissions, in particular in transport among other sectors.

Advances in ICT will have a double effect, both to improve road safety, and to help combat environmental degradation. Environmental protections stem from ICT's promise and ability to improve efficiency in energy production and use.

One major goal: today's stand-alone in-vehicle safety systems must evolve toward secure vehicle-to-vehicle and vehicle-to-infrastructure communication systems.

Reducing CO2 emissions is an EU priority for ICT applications. Particular attention is paid to ICT for what the EU calls Full Electric Vehicles (FEVs), which are essentially battery-electric vehicles (BEVs) as discussed in this *Handbook*. The term "Full" here refers to the freedom to power the battery without the manufacturers' requirement of an on-board petroleum-based ICE engine. The top EU priority for FEVs is integrating them with their necessary and complementary infrastructure. Projects supported under this objective will contribute to the European Green Cars Initiative, a Public-Private-Partnership launched in 2008 as part of the European Economic Recovery Plan.

In this context, these information and communication technologies have an important role in the Intelligent Transport Systems (ITS) described in Annex III

(State of the Art), and they are used in some ITACA regions in good practices and showcases with different goals:

3.3.3.1 Use of ITS to avoid congestion and “rush” hours

Mass monitoring and regulation of motorists through technology has been addressed among ITACA regions through opposite methods: the punitive method of paying a tax in Stockholm; and in contrast, receiving a reward if rush hour is avoided in Noord-Brabant.

Because of the potent behaviour change aspects of such interventions, they are first discussed in Chapter 2, sections 2.2.4 and 2.2.5, respectively.

In Stockholm, camera identification is employed. Motorists are automatically billed each month by postal mail.

Spitsmijden, in contrast, is not a trial like any other, and not only because participants are paid. This test is wed to advanced traffic information on a handheld computer, allowing the examination of the impact of this information on the travel behaviour of participants. This GPS system which monitors drivers for their rewards is thus multipurpose, given as an additional incentive to participate, as it also provides automated wayfinding services. Such services if successful potentially add to the behaviour change benefits by finding the most efficient pathways and reducing time spent lost.

3.3.3.2. Sustainable Traffic Management: maximizing use of existing system

The emerging field of Sustainable Traffic Management (STM) has great promise. A study recently completed for traffic solutions shows they could result in 40% reduction in accidents, up to 17% reduction in harmful emissions, reduce fuel consumption up to 12% and 14% reduction in travel times.

An example of STM is the *Green Wave*, in which it was found that timing traffic signals on a corridor for slower speeds actually improved conditions for all users; bicyclists could travel without stopping, very important for energy efficiency and encouraging a positive bicycling experience; bus transit ran more smoothly, with shorter run times; and even drivers enjoyed shorter travel times, counter-intuitively, because although they had lower peak speeds, their travel overall was smoother. The reduction in max speeds has tremendous implications for safety. The elimination of needless stopping and starting saves a great deal of energy, and reduces pollution as well as wear and tear costs on vehicles and infrastructure.

The primary risk with STM is that, in providing for smoother free flow, traffic

demand might be induced (e.g., the Kazzoom-Brookes postulate); after all, here the car could become more competitive with even the bicycle for short urban trips. In this case additional demand management strategies would be necessary to maintain the energy savings obtained, which are presumably needed in either case. At this time STM has great promise for a low-cost high-efficiency use of existing systems.

This is a measure that is very powerful as it can be implemented relatively quickly and is available immediately at the local level. At the same time, economies of scale are obtained the larger the treatment area. Regional solutions are also possible.

3.3.3.3. Inter-modal transportation systems: fare and ticketing integration systems

This topic is covered by the STIMER project, implemented in the whole regional territory of Emilia-Romagna. This project has been carried out to realise a new fare structure and the relative ticketing system for the entire bus and rail transport services provided within the regional territory.

This new system allows achieving the following objectives:

- to favour the highest level of integration among different transport modes and other mobility-connected services
- to provide users with the highest freedom of movement
- to assure easiness, transparency and flexibility of the fare structure
- to provide transport operators and local authorities with a reliable instrument for the planning and development of services and for the control of its use.

Since 1994 the Emilia-Romagna Region (ERR) has worked in synergy with the public transport companies to define a system that guarantees the maximum degree of integration between different transport modes. The regional council has defined principles, structures and other specifics for an integrated system of travel documents named STIMER. The region has since approved the zoning system. The fare structure consists of a zone-based price system: the travel zones are defined by taking into account both the specifics of the territory and the passenger movements in buses and trains. This has replaced the old flat-rate kilometric system and introduced a consumption-based fare system. In July 2001 a study of the zoning of the regional territory was commissioned involving all operators of the bus and rail services in the Region, aiming to define the fare zones and the effects resulting from the introduction of a regional integrated travel technology.

To manage the acquisition of the necessary technologies in a single associated form, an Acquisition Committee has been established comprised of all bus and rail transport companies in order to identify the technologies and software most

appropriate to serve all needs. This was made on the basis of the technical standards approved by the Bologna study.

An appropriate electronic travel document was sought, and the SEASON- CARD was chosen, a contactless card with an embedded microchip. This allows travellers to quickly swipe their card in order to communicate fare and other transactions.

The total amount of the Project is about 40 million Euros: 19 million Euros as a regional contribution funding the extension of the system to all urban and suburban buses and railways; and the remaining amount provided by bus companies and railway stations to update their ticket validation systems.

The main short-term goals:

- Transparency, easiness, facilitation in LPT access and use
- Fare system more faithful to the service; more flexible and efficient option
- Customer loyalty
- Demand promotion.

A major new technology adoption for a region is no small undertaking, and we look forward to the results analysis in the future by ERR.

3.4 Conclusions and Recommendations: Innovative Technologies

The use of innovative technologies alone for CO₂ saving is not enough. These new technologies must be complemented with other urban mobility measures in an integrated manner if we hope to achieve the necessary gains in carbon reduction and other goals.

In this context, innovative technologies, including new propulsion systems, low-carbon fuels and intelligent transport systems have a great potential to reduce CO₂ emissions, which have to be analysed in detail for every particular application.

ITACA partners have offered a wide representation of such technologies, with varied levels of development, implementation and success. This report gives a preliminary idea of their potential to scale over time, offering basic information about their characteristics and the approach considered in every region.

Accordingly, every technology has advantages and barriers, and there is no one solution for all regions and applications. However, common lessons do emerge:

- Public transport and administration fleets are priorities for action.

- Some priorities regarding the use of innovative technologies and low-carbon fuels are:
 - Substitution of conventional fossil fuel internal combustion engine vehicles with new ones having new propulsion systems such as, in order of cost and availability: hybrid, plug-in hybrid, battery-electric and fuel cell vehicles.
 - Increasing the use of biofuels (with total or partial substitution) in existing fleets, depending on the modifications to be done on the engines.
- The short and long-term potential of small-size battery-electric vehicles like pedelecs, micro-cars and electro-scooters for urban areas needs to be fully recognized and a European wide regulation is required to allow their swift and widespread diffusion.

A general conclusion related to the real impact of these technologies and fuels in terms of CO₂ reduction necessitates performing Well to Wheels (WtW) analyses as a preliminary step, prior to their incorporation in fleets, and as well as prior to their inclusion in mobility or environmental plans. To obtain results as close as possible to the real conditions of the emplacement, it is desirable to adapt the general and available data for this analysis with the particular data of such emplacement. For example, WtW analysis at the European level uses data from the EU electric grid mix. This data can be adapted to the particular national, or even regional, electric grid mix generation.

For “tank to wheel” data, it is vastly preferred that real operational data is used, as proposed in the database developed in the framework of this project. However, due to the limited availability of such data, that provided by manufacturers and testing laboratories may be the only option.

3.4.1 Propulsion systems and fuel types

The basic options are: battery-electric/hybrid-electric propulsion, bio-fuels and fuel-cells based on hydrogen or methane. Each of them have their specific potentials and limitations.

Burning biogas is thought to be largely carbon neutral as the raw material (biomass) has taken CO₂ out of the atmosphere during its growth. Biogas appears to be a promising way to reduce CO₂ emissions in short terms, not only in public transport, but also for trucks and individual users. The main advantages are: easy integration with existing natural gas vehicles (buses and cars); and local production from landfills and wastewater, integrated with local waste management. If an anaerobic process is used, the remaining material is not only treated for safety, but can be a potent agricultural fertilizer, as nitrogen is trapped in the liquid. The main disadvantages concern the limited availability and the challenges in managing the

resource, which greatly limits the maximum number of vehicles able which can be fuelled with biogas. If there is competition for organic resources, as with any biofuel, biogas is potentially at odds with other human needs. It is an open question to what degree a city can meet its transport needs with biogas, but the Swedish example is impressive, and growing, with the goal of a petroleum-free transport system well underway.

Without a doubt, blends of natural gas and biogas will be used as fuel in a higher volume of vehicles than today. In the short-medium term, another option for CO₂ saving could be the use of blends of natural gas and hydrogen. In this case, although the benefit in terms of CO₂ emissions reduction is clear at the utilization point, it is necessary to use WtW analysis to evaluate the real CO₂ saving. At present, natural gas reforming is the main hydrogen production method, which of course suffers from associated CO₂ emissions. In some particular cases, there is available hydrogen obtained as a sub-product of the chemical industry with no additional CO₂ emissions, thus increasing the CO₂ saving potential of these blends. Depending on the content of hydrogen in the mixture, existing vehicles can be used without engine modifications.

Electric motors deliver the highest efficiency energy conversion of all propulsion technologies, even if the electricity generation with a current energy mix is taken into account: for example from the ITACA database we find that the electric bus in Seville, Spain, consumed only 50% of the energy than the equivalent bus with a diesel engine (see chapter 3, Fig. 31). If energy comes directly from the grid, as with electrified trams trolleybuses, trams and other rail, the greatest benefit of all in energy efficiency is obtained, for we avoid the space and weight burden of an on-board power source, and we also avoid the large efficiency loss of charging/discharging. In theory the ideal city from a low-carbon perspective would be a dense city, with no cars, based around high quality electrified public transit for both people and goods movement.

The success of battery-electric and hybrid-electric propulsion is tied to the energy storage capacity and costs of batteries. With the introduction of Lithium batteries (used in portable computers) the battery-electric car development made a big step forward and significant improvements have been achieved every year. The costs of batteries are still very high, but low-weight vehicles at low speed do not need a lot of energy to move and the weight and costs of batteries can be kept small. This means electrification is particular suitable for small cars.

The other issue with electric vehicles is the energy generation. It is well known that if all electricity is produced from carbon-neutral sources then a purely electric car has zero CO₂ emissions associated with operation power (the manufacture, and the system used for travel, are another matter). The current situation is different, but the results are already encouraging: from the ITACA database we find that the battery-electric buses in Seville emitted only 14% CO₂ of what was emitted by the same bus-type running on diesel (see chapter 3, Fig 27).

The electricity-distribution can draw already on a vast infrastructure, the electric grid. However, as more battery-electric cars hit the road, a network of fast charging station needs to be built up and the electric transmission capacity of many lines needs to be increased.

The third propulsion option is based on fuel-cells which can transform hydrogen into electricity and water. The main advantage of hydrogen is its high energy density, which means a Fuel-Cell car, truck or bus is thought to have the same range as a normal gasoline car. From the user's point of view the refilling of hydrogen is similar to the refilling with gasoline, no prolonged charging times are necessary. Technical feasibility is being demonstrated in several projects, but economic feasibility still needs some years before it can be achieved. Concerning energy consumption, from the ITACA database (see chapter 3, Fig 27) it is not clear if there is any potential for energy saving by introducing hydrogen and fuel cells: The New York Transit bus with diesel consumed almost the same (well-to-wheel) energy per km then the best test result of the Cute experiments, using Fuel Cells of a similar bus (similar motor power). It would have been instructive if the Cute experiments had also released data for the same buses in diesel version. Similar result can be confirmed from the Zero project, where small passenger vehicles with internal combustion engines consumed approximately the same energy per km then the same vehicles equipped with Fuel-Cell driven electric motors.

Currently, hydrogen is mainly produced by methane reforming, which releases CO₂, and makes it dependent on petroleum. Still, the production of CO₂ per km of a Fuel-Cell vehicle is approximately 60% of an equivalent car with a conventional internal combustion engine, as demonstrated with the Zero project (see chapter 3, Fig 27). The emission of CO₂ can be largely eliminated if the hydrogen were produced by electrolysis and the electricity required for the electrolysis is produced by carbon-free energy sources. On the other side the electrolysis and gas compression also consumes energy and would reduce the overall energy efficiency.

Production and infrastructure for hydrogen distribution is currently non-existent. Electrolysis facilities for huge volumes must be built, just as compression facilities, hydrogen storage and distribution. This is a monumental challenge, a major investment, not to be undertaken lightly.

3.4.2 Outlook

When assessing and recommending the short and long term prospective of propulsion/fuel technologies, it is of paramount important to differentiate by the following transport applications:

- Urban person transport: short distance, urban trips at slow to modest speeds, often stop and go traffic. The largest part of the population lives in urban areas and most trips fall under this category. Any improvement for this

application will not only reduce significantly energy consumption and carbon emission on a national and European scale, but also the reduction of local pollutants and noise has a highest impact during urban trips.

- General person transport: for all trip purposes and distance, similar to the present automobile. These are all trips that do not fall under urban trips, including long distance commuting or holidays. This is not the majority of trips, but accounts for a large share of person km travelled.
- Urban freight and small size collective transport: short distance transport of small to medium size freight that can be transported in vans or small-size trucks and buses. Most freight trips are local or regional and again, the reduction of local emission and noise of in this category would have a huge benefit for cities.
- General freight transport and collective public road transport: road freight transport for all distance and weight classes; larger buses for public transport.

Present and short-term prospective:

- Urban person transport: light-weight, short distance and low, speed is the top application for electro-mobility. There is a wide range of battery-based products hitting this market: Pedelecs (bikes with an electric motor as support) are available in the range of 1000€ , battery-electric motorbikes in the next price range; and micro-cars and mini-cars from 5000€ to 20,000€, dependent on range and speed; electro-scooters and electro-boards are available in some countries for a few hundred Euros. The latter is attractive for young people without driver's license. Even though some of these products are new and need some time to mature, the main obstacles for their swift introduction if not of technical nature:
 - The lack of national regulation is a main hurdle. The current situation in many countries confuses consumers, producers and retailers. Different regulations apply in different European countries, in particular for Pedelecs, scooters, E-bikes and other vehicles with speeds below 45km/h. It is mandatory enforce as soon as possible a unique European-wide regulation in favour of E-mobility that assures both, quality standards and safety.
 - Behavioural change is required. To make full use of E-mobility it is necessary to manage battery charging for transport, just as for mobile electronic devices. Some vehicles require to charge during night if completely empty. Even “quick charging”, if available, takes several minutes. Plugging the vehicle whenever and wherever possible needs to become a habit. E-scooters and E-boards offer new possibilities to travel in the city: they can be folded and carried as

hand-luggage in public transport with ease. The benefits of all these changes need to be communicated and marketed properly.

- Carbon-free, multi modal trip-chaining: short distance-urban E-mobility could be used to complement and extend an already existing public transport network; in particular the catchment area of currently under-used public transport links could be extended for example by offering park&ride space reserved for electric vehicles. Local governments and public transport operators must collaborate and find out the best solutions on how to “filter” E-mobility into their cities by employing their most valuable assets: access restrictions and parking space. Again these are measures discussed in the demand management chapter.
- General person transport: hybrid vehicles offer an available and mature technology that is well established in the market, but which still has great potential for growth, not only for individuals but also in sectors with fleets such as taxi companies. Additionally, the commercialization of plug-in hybrid vehicles promises to pave the way to the introduction of pure, all-purpose electric vehicles. Public grants for the acquisition of hybrid vehicles, provided with a simplified procedure to apply for the funding, have demonstrated a high degree of success in some regions like Andalucía, and, in combination with other measures, such programmes are very promising. ITACA recommends inclusion of this type of measure in future policies and plans at both the local and regional levels as short-term measures for the reduction of carbon emissions, as well as the reduction of other forms of harmful air pollution which injure populations more directly. Pure battery-electric vehicles become increasingly available, but are currently more expensive than hybrids and have to date a limited range.
- Urban freight and small size collective transport: small electric vans and buses are already on the market and are appropriate for short distance deliveries into urban areas that are particularly sensitive to local emissions and noise. Rental systems based on electric vans have been implemented in Emilia, Italy, see chapter 2.
- General freight transport and collective public road transport: heavier road vehicles or long distance trips are not suitable for battery-electrification. The most sustainable alternative already available are clearly bio-fuels. The most cost efficient are currently gas or various gas blends with hydrogen. The potential to utilise existing trolleybus systems for electrified mass transport is worth investigation.

Short-medium term perspective:

- **Urban person transport:** If market barriers such as regulations are removed and the right policies were put in place then E-mobility, with its vast choice of electrified vehicles, will continue to increase its share in urban transport -- as battery prices are expected to drop further. Also ordinary battery-electric cars are expected to play an increasing and eventually fundamental role in urban mobility. After several unsuccessful attempts throughout the history of the motor vehicle, it appears that the battery-electric car is here to stay in our cities. All the ITACA regions have experiences and initiatives in this area, covering a wide field of applications. Most of these cases are focused not on particular drivers, but in both private and public transport fleets, and car-sharing services. Thus, organizational and public offers appear to be the primary or first-users of this technology. The development of electric vehicles also requires the development of necessary infrastructure, with the associated challenges and barriers in terms of costs, legislation, etc. This technology will progressively gain presence in urban transport scenarios, but significant participation by the public will only be achieved in the medium-term, after these gaps have been solved through the use of the technology in public transport and early innovator fleets.
- **General person transport:** Hybrid electric vehicles are expected to gain shares in all purpose passenger cars. The share of natural gas and biofuels is also expected to increase. Both, hybrids and biofuel production are mature technologies, their large scale introduction will largely be controlled by the evolution of the oil price. With the rapid advances in battery technologies, also the battery electric car may become a valid competitor in this application, at least in medium terms.
- **Urban freight and small size collective transport:** hybrid electric and full battery electric vans and buses become more financially attractive as battery prices fall and oil prices increase.
- **General freight transport and collective public road transport:** Different compressed gas blends and bio-fuels are likely to remain the only sustainable alternatives to gasoline. The only technical alternative, the fuel-cell electric engine, would require its own new hydrogen infrastructure and is unlikely to play a significant role in medium terms.

Medium- to long-term perspectives:

- **Urban person transport:** with the right policies in place, the motorized person transport in cities could become essentially emission free. Electric vehicles of all sizes become available at affordable prices.
- **General person transport:** for larger cars with long ranges, there are 3

options

- Bio-fuels
- Electric or Electro- Hybrids (using electrical energy and bio fuels)
- Hydrogen Fuel cell cars

All three options are carbon-free, but each with advantages and limitations as discussed before: Bio-fuels are likely to be limited in quantity; larger electric cars will be more expensive due to the batteries, while the costs per km will be lower due to the motor's high efficiency; hydrogen cars are expected to have high costs compared to present cars, and the cost per km will be more expensive compared to the battery-electric car (requires approximately twice as much electricity), due to the much lower overall efficiency and the costs of the hydrogen production and distribution. As a bio-fuel only solution for all the person transport seems a battery electric or electro-hybrid/bio-gas solution (or a mix dependent on the success of future battery developments) is likely to be the less costly solution with respect to the hydrogen fuel cell option.

- Urban freight and small size collective transport: for short distances and smaller/lighter freight battery electric and hybrid/biogas vehicles are likely to be the most cost sensitive solution.
- General freight transport and collective public road transport: for heavier vehicles and long distances, there is *de facto* only the bio-fuel and the Hydrogen Fuel-Cell option at present, yet direct electrification through grid-connected vehicles (e.g., the long-proven trolleybus, and electrified rail, but also the hypothetical Personal Rapid Transport, and trolleytruck concepts) may be superior for many future purposes given adequate assessment, research and development as needed. If the supply of bio-fuels were sufficient for this application then this would be the least expensive solution, but concerns of competition with food, and environmental degradation, must be respected. If we want the supply of bio fuels to be sufficient, the appropriate strategy would be:
 - For heavy collective transport, the recommendation is to use trolley buses, trams and rail wherever possible to be supplied directly from the electric grid
 - Transfer more large long distance cargo from road to rail
 - Continue research into emerging technology like HFC, and alternative concepts like GCV trucks and PRT.

The question whether FCEVs will have a significant share in the future transport market will remain open as the exact costs of a fuel-cell car are yet unknown. As mentioned above the FCEVs are likely to face the hybrid/biofuel and probably the battery electric car as competitors, even for long range distances. But if FCEVs cannot claim a widespread diffusion in the car-market, it is unlikely that a large-scale hydrogen production and an area covering hydrogen supply network will be established. It remains to be seen if in this scenario Fuel Cells can dominate the

long-distance heavy freight transport and buses. One possibility are hydrogen filling stations along highways or in bus depots of public transport operators.

Although the main automakers have plans to produce small series of FCEVs at reasonable cost in 2015, further reductions in costs and the deployment of such infrastructure are the main challenges to be overcome in the coming years, predicted to come mainly thanks to demonstration projects of such vehicles in real life urban situations.

In the short- to medium-term, the use of electricity from renewable energies in electric vehicles should be one of the main ways supported to achieve the objective of “Zero Emission Vehicle”. The main issues of concern for this goal are legislation and scaling up the production of electric vehicles to lower costs. Furthermore, it should be suitable to develop a harmonized and equivalent procedure at the European level to guarantee the origin of the electricity used to recharge a vehicle, in order to evaluate it in terms of CO₂ emissions reduction in a common manner. Some countries are planning super-reduced-tariffs to incentivize the use of electric vehicles. A unified legislation, in particular for a range of electric vehicles (from scooters or mini-cars) would allow to bring them faster market. Small electric vehicles are ideal and efficient with batteries, and they could become a competitor for the normal car for urban trips.

One problem with the electricity is that electricity obtained from renewable energies is sold at a higher price than normal electricity; thus, if there is no incentive for greener, low-carbon energy, the consumer base will tend to prefer the cheapest electricity mix available, directly from the grid. In some countries, with a smaller penetration of renewable energies, this choice would be an additional gap to the deployment of such energies. In the long-term, the integration of renewable energies and electric vehicles is expected to be reinforced through the use of smart grids, and as an innovative and more efficient use of resources. For example a smart grid device which is always updated about the current electricity cost, would charge a battery only if the electricity cost is below a predefined level. In this way batteries of electric vehicles can be used as storage systems to balance the supply of renewable energies like wind or solar.

3.5 References and Additional Information

3.5.1 State of the art references

[1] Transport, Energy and CO₂: Moving toward Sustainability - How the world can achieve deep CO₂ reductions in transport by 2050. International Energy Agency. October 2009.

[2] European Commission (2010): EU energy and transport in figures - Statistical pocketbook2010.
http://ec.europa.eu/transport/publications/statistics/statistics_en.htm

[3] Research of the EU automotive industry into low-carbon vehicles and the role of public intervention. T. Wiesenthal, G. Leduc, J. Köhler, W. Schade, B. Schade. JRC58727-2010.IPTS.

[4] Outlook for hybrid and electric vehicles. Hybrid and Electric Vehicle Implementing Agreement. International Energy agency

[5] Plug-in Hybrid and Battery Electric Vehicles. Market penetration scenarios of electric drive vehicles. Françoise Nemry and Martijn Brons JRC58748 – 2010. IPTS.

[6] Electrical Vehicles: State of Art and Issues for their Connection to the Network. Eduardo Valsera-Naranjo, Andreas Sumper, Pau Lloret-Gallego, Roberto Villafáfila-Robles, Antoni Sudria-Andreu Electrical Engineering Department, Universitat Politècnica de Catalunya (UPC) Centre d'Innovació Tecnològica en Convertidors Estàtics i Accionaments (CITCEA), Barcelona, Spain. September 2009

[7] A. A. Ferreira, J. A. Pomilio, G. Spiazzi, and L. de Araujo Silva, "Energy management fuzzy logic supervisory for electric vehicle power supplies system," IEEE Trans. Power Electron., vol. 23, no. 1, pp. 107–115, Jan. 2008.

[8] State-of-art of Energy System for New Energy Vehicles. September 2008. Liqing Sun. Beijing Institute of Technology, Beijing, China. C. C. Chan. Hongkong University, China. Ruchuan Liang China Academy of Launch Vehicle Technology, Beijing. Qingcai Wang DongFeng Automobile Co., Ltd., Wuhan

[9] W. D. Jones, "Take this car and plug it [plug-in hybrid vehicles]," IEEE Spectr., vol. 42, no. 7, pp. 10–13, Jul. 2005.

[10] S. G. Wirasingha, N. Schofield, and A. Emadi, "Plug-in Hybrid Electric Vehicle developments in the US: Trends, barriers, and economic feasibility," Proc. IEEE-VPPC, Harbin, China, Sep. 2008, pp. 1–8.

[11] M. Ehsani, Y. Gao, and J. M. Miller, "Hybrid Electric Vehicles: Architecture and

motor drives,” Proc. IEEE, vol. 95, no. 4, pp. 719–728, Apr. 2007.

[12] A. Emadi, K. Rajashekara, S. S. Williamson, and S. M. Lukic, “Topological overview of hybrid electric and fuel cell vehicular power systems architectures and configurations,” IEEE Trans. Veh. Technol., vol. 54, no. 3, pp. 763–770, May 2005

[13] M. Eshani, Y. Gao, S. E. Gay, and A. Emadi, Modern Electric, Hybrid Electric, and Fuel Cell Vehicles. New York: CRC, 2005.

[14] New Generation of Passenger Vehicles: FCV or HEV? Moghbelli, H.; Niasar, A.H.; Langari, R

[15] J. S. Lai and D. J. Nelson, “Energy management power converters in hybrid electric and fuel cell vehicles,” Proc. IEEE, vol. 95, no. 4, pp. 766– 777, Apr. 2007.

[16] EUROPEAN NATURAL GAS VEHICLE RESPONSE 15 JULY 2007. Public consultation on the implementation of the renewed strategy to reduce CO2 emissions from passenger cars and light-commercial vehicles.

[17] State of the art and potential of biomethane vehicle fuel. Joint study by ADEME, AFGNV, ATEE Club Biogaz, GDF SUEZ, IFP, MEEDDAT.

[18] Biogas as a road transport fuel. Research undertaken for the National Society for Clean Air and Environmental Protection

[19] Modelling Intelligent Transportation Systems and Their Implications for Climate Change. Jennifer Armstrong, M.Eng., P.Eng. Morrison Hershfield Ltd. Carleton University Ata Khan, Ph.D., P.Eng. Carleton University

[20] RITA Research and Innovative Technologies Administration. Intelligent Transportation System. <http://www.itsoverview.its.dot.gov/>

[21] Transport Revolutions: Moving People and Freight Without Oil. Richard Gilbert and Anthony Perl. May 1, 2010. New Society Publishers. <http://transportrevolutions.info/>

3.5.2 Showcases and good practices additional information

Promotion of hybrid vehicles in the public transport – Taxis (Andalucía)

http://www.agenciaandaluzadelaenergia.es/agenciadelaenergia/nav/com/contenido.jsp?pag=/contenidos/incentivos/incentivos_09&id=2

GreenCab – EV taxis (The Netherlands)

<http://www.prestigegreencab.nl/home/waarom-greencab/>

Battery-electric car sharing –COCHELE (Andalucía)

<http://www.cochele.es/>

Development of a fuel cell vehicle fuelled with hydrogen produced from renewable energy -Hércules Project (Andalucía)

<http://www.proyectohercules.es/>

Biogas in Swedish municipalities (Stockholm region)

http://www.sorab.se/pdf/Sorab_UK.pdf

<http://www.stockholmvatten.se/en/Purified-wastewater-to-protect-the-environment/Waste-products-recycled-into-new-resources/>

<http://sl.se/sv/Om-SL/Miljo/Biogas/>

IDROMETANO - Hydro-Methane - Hydrogen and Methane blend for public city transport bus. (Region Emilia-Romagna)

<http://mhybus.ning.com/>

Congestion tax– electronic road pricing in Stockholm region (Stockholm region)

www.transportstyrelsen.se

www.stockholm.se

Rush Hour Avoidance in Randstad Holland/Brabant (Noord-Brabant)

www.spitsmijdeninbrabant.nl

STIMER Project – Fare and ticketing integration systems (Region Emilia-Romagna)

<http://www.mobiliter.eu/wcm/mobiliter/pagine/tariffe.htm>

Chapter 4: ITACA Conclusions

Of paramount importance to the ITACA effort is discovering – through our collective efforts and through the sharing of our experiences – our recommendations for best paths to sustainability solutions. It is imperative that we recommend specific actions for others, and the best order in which to undertake them.

How much of our limited resources should go into new propulsion systems, versus new behaviour change programmes, for instance? What gives the greatest results for the investment?

When cities and regions look to ITACA for next steps in their efforts, which programmes and practices stand out as the most effective? In fact, there are many approaches, each fulfilling certain specific functions; we need a diversity of approaches, not just one solution. Together, these efforts collectively make a greater difference than any alone. We have seen that there are many cultural differences, for example, in particular when it comes to behavioural changes. The way car-restrictive measures have been introduced differently, in different countries, is just one example.

The sum is greater than the parts. Assessing each action's true carbon emissions savings and its potential applicability far and wide is an important goal, but one not easily accomplished in the context of urban and municipal entities: often we are left having to choose programmes without metrics as clear as we would like, and protecting the climate becomes an art as well as science.

What can we do today, to best protect our climate for the long-term?

In this *Handbook* we have explored a range of options and approaches under the two general headings of Demand Management Models and Innovative Technologies, each of which was given its own chapter with its own more specific conclusions and recommendations than found here. Both are essential strategies for the modern necessity of transport. Both must be employed wisely for best effect. We cannot rely on either alone.

In theory, the ideal city from a low-carbon perspective would be a dense city, with no cars, based around high-quality electrified public transit for both people and goods movement, with the electricity coming directly from renewable sources. Such a city, if properly designed, would provide the highest access and mobility to all, including the young, old, and people with disabilities, with the least environmental harm.

While technology solutions have promise to replace existing fleets and their power sources over time, with some solutions available now, in the short-term the most

major gains available would come from behaviour change – through better utilization of existing options, whatever the technology at hand – walking and cycling being the mode of choice whenever possible. Next in line, and very promising, battery-electric bikes and low-cost micro-electric cars that are tailored for urban speeds and short distances are already available in some countries and could replace a significant part of our trips, but like the other soft modes, these also need a safe place to be used, as well as a place to safely park and recharge.

Certainly, we can do better through changes of behaviour: not every bus, train and tram is as full as it could be; many if not most private cars carry only one occupant; and many millions of trips each day, in every country, are within easy walking and bicycling distance. In terms of brilliant technology, the bicycle is our most energy-efficient form of land transport, renewably powered by a delicious fuel known as food, with the additional co-benefits of good old fashioned exercise and zero pollution. Likewise, each new transit or carpool passenger adds little to the costs of the route, effectively making ever greater and more efficient use of an existing expenditure of carbon, energy and resources. Bikes, electro-bikes and electro-scooters could extend the catchment area of rail stations; some scooters can even be folded and brought into a bus or train as hand luggage – if people would start thinking and choosing in terms of low-carbon trip chaining.

Shifting behaviour may seem a complex challenge given the trend toward the private automobile, and with respect to individual and economic freedom. Yet as we have seen with ITACA efforts detailed herein, there are promising gains to be made through a variety of innovative means, and it is in our collective interest to do so. In particular, it is essential that sustainable alternatives are convenient and cost competitive: from incentives for good behaviour and pricing strategies; to bringing destinations closer through wise land use; to providing new supply options such as bike share systems, or the replacement of the present, carbon-based fuel dependency. An important lesson learned is that demand management methods must be well adapted to the culture of the population and the local mobility demand supply. In particular, car-restrictive methods like a congestion tax or congestion pricing area would not gain the same favor in all places, despite the successes in Stockholm and London, although it is important to recognize that as with many changes, those measures were first in disfavor, and later broadly cheered. Withstanding controversy is sometimes necessary to usher in benefits for all.

Ultimately, in the longer-term, even if technology solutions succeed and spread to provide renewably powered propulsion systems for mass use, we must consider the efficiency of the overall system. Land use changes and local provision of needs can bring origins and destinations closer together, obviating the need for energy and resource expenditures not just to provide *what makes it go*, but also the massive systems of infrastructure *that it goes on* and *how far it must go* to meet the same needs.

These changes do take time, even generations, yet as we saw with the APEA canteen example, substantial gains can be won in the medium-term simply through

relocating a major destination closer to its users. Moreover, if a course for energy-efficient land use is not set at once, our untethered ship may continue its wayward drift into a swamp of sprawl and automobile dependency ever more difficult to disentangle from. Development patterns and the provision of new transport systems remains critical to steering our mighty ship through this storm – not only for the climate but for the quality of our living environments and the freedom to choose how we travel.

At the local and regional planning level, mobility planning has achieved rewarding results. From a behaviour change perspective, the Emilia-Romagna Region's mobility plan has successfully shown sweeping changes occur. From the land use perspective, while charting future growth in the Stockholm Comprehensive Plan, coupled with its innovative Environmental Plan for the commuter-island of Lidingö, long-term gains are again projected. In a third regional planning example, in a contrasting environment where unfortunate land use has created endemic problems of car dependence in the Huelva Province of Spain, another large planning effort seeks to use demand management through new supply, and new restrictions, to turn the tide and achieve real gains in energy efficiency and emissions reductions in the 12-18% range throughout the region. Thus ITACA partners illustrate large scale approaches to a diversity of regional circumstances.

Information and communication technology systems (ICT) are of particular utility at the regional level and beyond. ICT approaches have been developing improvements for years now, with many in operation. Such measures are able to optimize current transport systems (mainly in traffic flow management, priority traffic light for public transport and logistics, as well as personal wayfinding), and can likewise improve the quality of public transport (for example through navigation and passenger information systems). Many ICT measures have also been combined with demand management. We have seen the different ITACA showcases where congestion charges and access control schemes have been demonstrated to work effectively.

Powering vehicles is also a place where technology can make a significant contribution today in lowering the power consumption and carbon emissions of individual mobility, by replacing internal combustion engines with electric motors, whether driven by directly by electricity, or by on-board storage using a battery or fuel cell.

In this field it has been shown that there are cost-effective Electro-mobility products already hitting the markets. From electro-scooters and electro-bikes to mini-electric cars – short distances at low speeds are the ideal application for battery driven vehicles and coincidentally, these are the trips that characterize a large share of all urban mobility. The main barriers identified are a missing regulatory framework that sets Europe-wide quality and safety for such devices, and the familiar problem of space that already so plagues the soft modes, walking and bicycling: where shall we accommodate these sometimes slower, smaller and more vulnerable vehicles? Not just for travel, but for parking? How can we allow the elegant solutions at hand

to take hold, such that their users feel safe, comfortable, and supported?

Bio-fuels are an additional strategy with immediate availability for a short to medium term effect, as the technology is already mature. Bio-fuels are suitable as gasoline replacement for all transport applications, including buses and heavy trucks, even though current combustion engines would need to be replaced for fuels with high bio-fuel content. The availability of bio-fuels is limited on a world-wide scale, unless ways are found to produce bio-mass sustainably and ways that do not compete with food. This means it would be wise to use bio-fuels for applications like heavy trucks and larger buses, where battery-electric solutions are not cost-efficient. Then again, in any fixed route system, electrification gives the greatest long-term benefits in a great many cases. Putting electric trucks and buses on wire affords great energy efficiency and low carbon emissions, and if implemented on a large scale, should be the most cost-effective of all land-based, motorized mass transport (see Chapter 3, GCVs).

Regarding the one-to-one replacement of the gasoline car by electric vehicles, the short term potential is more limited, but the long term potential is significant. This is mainly due to the need to (1) develop more cost-efficient batteries with high energy density and (2) to convert the entire electrical energy production to use carbon neutral methods. A short term solution for the former problem are the different variants of hybrid electric vehicles which are already on the market, but which are still dependent on combustion, and only yield a partial reduction in emissions.

Even if we had the power to magically transform each private vehicle to a zero emission vehicle, many problems would remain. The energy and resources used for a dispersed urban land use designed around automobile are inherently costly, and the social costs are also large. To strive for a diversity of land uses obviating car dependency is a much safer and more comprehensive solution to not only the problem of carbon emissions, but to many urban ailments we face today. The novel goal of carfree districts, and even cities, discussed in Chapter 3, particularly if supported by electrified transport, is certainly true to the ideal of minimizing harm while maximizing benefits, and thus may eventually prove to be the most popular and economically powerful solution if given a chance, but this requires a combination of strategies as discussed throughout this *Handbook*. The fact that such developments are popular and lead to residents giving up their cars voluntarily shows that an important unmet demand is waiting to be filled.

Hope is thus ever on the horizon. Let us bring it closer. *Yes we can* shift behaviour, and over time that includes both our technology choices and our physical environment. In proceeding, there is indeed urgency, and every option must be used to best effect, in concert. Let the music begin.

Annex I: Demand Management Models

The goal of this Annex is to summarize the showcases/good practices about Management Models received from the ITACA partners. The distribution of showcases/best practices into the three subtopics is as follows:

- Behaviour Change
 - Emilia-Romagna Regional Mobility Plan
 - Environmental Management and Sustainable Mobility of Health Care Companies in Emilia-Romagna
 - Pedibus: providing a structured opportunity for elementary and middle-school students to walk to school together. The walking group mimics a bus, with regular stops and a regular schedule. (Examples from ERR and Italy: Rimini, Bologna, and Ferrara; Turin.)
 - Congestion Tax: changing behaviour through pricing, by introducing a higher charge for entering a congested area during peak times. (Stockholm.) Also described under “Intelligent Transport Systems, ICT applications” in the Innovative Technologies section, Chapter 3.)
 - Spitsmijden: Financial rewards are given to drivers who change behaviour by not driving into the center during peak times. Also described under “Intelligent Transport Systems, ICT applications” in the Innovative Technologies section, Chapter 3.)
 - Bicycle repair, plus financial incentives to use trams, Rimini (also in supply/demand) (Somehow tied to Free Employee bikes (“Bike Sharing”))
- Land Use Planning Policies
 - SWEDEN: Comprehensive & Environmental Plans. Lidingö
 - APEA Canteen (No showcase doc, other parts below)
 - Zona Universitaria Semi-pedonalizzazione
 - (See ERR “MoTe 2009_Carlini_Merci_002”)
- Transportation Supply/Demand Management
 - Green Parking
 - Bicycle paths in the Province of Rimini
 - Bike Sharing: two projects:
 - Italy (“C’entro in Bici”), Ferrara (and Free Employee bikes (“Bike Sharing”))
 - Public Transport Bike (OV Fiets)
 - CONCABUS or Valcona
 - APEA Bus/Bike Potential Mode Shift

1.1 Behaviour

Template ITACA showcases		
1	Title of the showcase / best practice	Emilia-Romagna Regional Mobility Plan
2	Objective of the showcase	Reducing the use of private transport to travel to work while at the same time encouraging the use of group transport and other means of transport associated with a low-level environmental impact. A significant part of the proposed interventions involve actions aimed at developing public transport with a view to achieving sustainable mobility.
3	Metropolitan region / city	Over 3,000 employees located throughout the whole Emilia-Romagna Region
4	Owner/executor and participants	Employees, Emilia-Romagna Regional Council, Local Public Transport Companies, visitors to Regional offices, Municipality of Bologna and the national and regional railways companies
5	Description: - Content and process - Timetable - Finance - Results	<p>Started in 2003 the Regional Mobility Plan is a constant work-in-progress continuously updated, it has been drawn up bears all the typical hallmarks of mobility management and is primarily aimed at influencing individual behaviour rather than relying on the much more commonplace structural-type interventions. However, in order to succeed in significantly impacting behaviour, it is often necessary to intervene at a structural level too, for example by providing cycling lanes or other lanes reserved for public transport. The Plan, along with the proposed actions and solutions that appeared likely to prove suitable and convenient over time, also took into account a further level of complexity by considering the substantial number of employees who had specific family issues and/or children of school-going age. Such a desirable and crucial result is to be achieved first and foremost through a subsidy scheme in favour of subscribers to public train and tram/bus services, and at the same time, by introducing a small fee for the use of the Regional Council's own parking spaces that up to now have been provided entirely free of charge. The various hypotheses taken into consideration exclude any contribution towards the cost of parking spaces allocated at Regional offices for disabled persons, expectant mothers, and workers who have opted to pool cars that transport at least two persons besides the driver. Other means include an increase of company and inter-company services.</p> <p>Equal importance has been given in the Plan to interventions aimed at rationalizing travel routes by</p>

		<p>car regarding those categories of users who have no intention of choosing alternative forms of travel. This often unmotivated and arbitrary practice leads to an irrational increase in traffic, the key factor in road congestion levels and atmospheric pollution that sadly is only too often evident. The decision to promote, support and provide alternative environmentally friendly incentives such as car pooling and car sharing is deliberately aimed at reducing the number of one-person car users and thereby making a significant impact on the very serious and harmful consequences described above.</p> <p>Other aims include an in-depth investigation to identify ways to improve access for pedestrians and cyclists to Regional offices throughout the territory, in concert with the relevant council offices. This includes putting in place the necessary structures: parking areas, antitheft and anti-vandalism systems etc. Another essential support, conceived as a supplementary measure in such a broad-ranging and ambitious plan, will be provided in the form of a programme for the gradual substitution of the Regional Council's fleet of vehicles – both directly owned and leased via service contracts – with low to zero-environmental impact models. The Plan drawn up by the Emilia-Romagna Regional Council has another characteristic that is inevitably and inextricably linked to principles associated with Mobility Management, and that is the high level of integration with the activities of external bodies and businesses such as other City Councils, Provincial Councils and Transport Companies.</p> <p>The Plan comes with a series of indicators for assessing the efficiency of the strategies adopted, as well as forming the basis of eventual corrective measures. Other extremely important elements that need to be considered include the productivity of employees, which tends to increase as levels of travel-related stress fall, as well as benefits in terms of energy saving and safety. Opting for public transport solutions automatically implies a net improvement in safety.</p>
6	Low Carbon Contribution (quantify if possible)	<p>On average, CO₂-emissions for train travel are three times lower as car travel, as well as bus travels are widely most efficient both from the environmental and energetic point of view. Before the introduction of the Regional Mobility Plan users of public transport amounted to some hundred, currently they annually amount about 2,300 out of 3,000 employees.</p>
7	Lessons learnt	<p>When it comes to sustainable mobility, a valid and efficient action aimed at decreasing the number of cars on urban roads consists in the identification of</p>

		workers' specific needs, the provision of information on available alternatives, and the simultaneous promotion of related incentives. As regards suppliers in particular, it was considered necessary to encourage them to opt for means of transport that generate less pollution; an initiative of this kind cannot be evaluated exclusively on the basis of the added value that it may result in for the Region's image, but rather for the domino effect this could produce in other public administrations and private organizations.
8	Other relevant information	Another scenario, again characterized by the inevitable need for suitable structural interventions, regards the possibility of walking to work. One of the chapters in the Plan entitled "Improving Accessibility to Regional Offices through Pedestrian Routes" is specifically devoted to this issue. Getting employees involved means putting in place an on-going and widespread information and publicity campaign. Indeed, the Plan has given priority to precisely these elements. The campaigns are comprised of a series of interventions, which will be carried out on a theme by theme basis. Web sites are considered to be a useful point of reference for obtaining information on existing transport modes and maintaining a direct link to employees, but too often these sites are scattered throughout the Internet as are notices on the establishment and implementation of new services. The information will also serve to highlight a crucial issue that otherwise may have been overlooked – the implementation of a project of this kind does not just involve the protection and renewal of the environment or the development of a modern and flexible form of collective mobility, able to resolve the problems of congestion in urban areas.
9	Website	http://www.regione.emilia-romagna.it/mobilitymanagement/

Template ITACA showcases		
1	Title of the showcase / best practice	Environmental Management and Sustainable Mobility of Health Care Companies in Emilia-Romagna
2	Objective of the showcase	The project on the coordination of the 17 Health Care Companies existing in Emilia-Romagna was promoted within the regional initiative aimed at reducing atmospheric emissions by encouraging non-polluting forms of transport and therefore less harmful to the environment and human health. Since 2008 the regional working group "Sustainable

		Mobility of Health Care Companies” investigates the possibilities of reducing the use of private transport to travel to work while at the same time encouraging the use of group transport and other means of transport associated with a low-level environmental impact.
3	Metropolitan region / city	Over 60,000 employees located throughout the whole Emilia-Romagna region territory
4	Owner/executor and participants	Employees of the 17 Health Care Companies, Emilia-Romagna Regional Municipalities, Local Public Transport Companies, visitors to Regional Hospitals, national and regional railways companies
5	Description: - Content and process - Timetable - Finance - Results	The Project has entailed above all arriving at a better understanding of, and therefore a reduction in the overall negative impact the 17 Health Care Companies produces on the environment through the mobility of its employees and its activities. The main goal was to encourage compliance by Health Care Companies with the Ronchi Decree on Mobility management, otherwise widely disregarded, to rationalize work-related journeys by promoting alternative travel modes to the automobile that would significantly reduce traffic congestion as well as atmospheric and noise pollution. During the last four years have been carried out an extensive series of investigations
6	Low Carbon Contribution (quantify if possible)	
7	Lessons learnt	
8	Other relevant information	
9	Website	

	Template ITACA showcases	PEDIBUS Walking to school
1	Title of the showcase / best practice	Pedibus is an initiative which gives opportunity to elementary and middle school students to be walked to school by their parents or volunteers who in turns will walk the students to school through safe paths. There are more than 1000 students involved in the project, both in the city of Rimini and in smaller towns as Verucchio, San Leo, Novafeltria. The project has two objectives: to educate to the respect of the environment and to reduce the use of private cars.
2	Objective of the showcase	To increase pedestrian mobility
3	Metropolitan region / city	Province of Rimini and mentioned towns
4	Owner/executor and participants	City of the Province
5	Description: - Content and process - Timetable - Finance - Results	Started in 2008, the project is expanding involving more and more students. Euro 6.760,00 school year 2008/2009 and Euro 5.000,00 for 2010.
6	Low Carbon Contribution (quantify if possible)	-1% Co2 for year.
7	Lessons learnt	Improvement of the already existing programs
8	Other relevant information	---
9	Website	http://www.provincia.rimini.it/progetti/mobilita/index.htm

Template ITACA showcases		PEDIBUS
1	Title of the showcase / best practice	The Pedibus, a bus that goes on foot, is formed by the caravan of school children going to school in groups accompanied by their parents and teachers, which in turn have the role of "driver" in front and "controllers". It's a real bus, departs from the terminus in one street and following an established route to collect passengers "stop" in place along the path, while respecting the fixed time.
2	Objective of the showcase	The walking school bus is a way to improve the quality of urban environment in the vicinity of schools, helping to reduce traffic congestion, noise and air pollution resulting from the practice of accompanying children to school by car
3	Metropolitan region / city	Comune di Ferrara
4	Owner/executor and participants	Comune di Ferrara, AMI and parents of children
5	Description: - Content and process - Timetable - Finance - Results	Today, the walking bus is permanent (all year-round school) for one elementary school. The project was mainly done by administration staff
6	Low Carbon Contribution (quantify if possible)	lower emissions in a year
7	Lessons learnt	This experience is absolutely normal for all children not more than thirty years ago, today it is considered impossible by almost all Italian families.
8	Other relevant information	
9	Website	http://www.ami.fe.it/index.phtml?id=835

Section	Indication of content
1 Title of the best practice	Congestion tax
2 Precise theme/issue tackled by the practice	In Sweden we use the system with congestion tax in Stockholm.
3 Objectives of the best practice	To reduce congestion, emissions and to fund new roads in the region.
4 Location	Sweden

	Stockholm city
5 Detailed description of the best practice	<p>The congestion tax was implemented on a permanent basis on August 1, 2007, after a seven-month trial period between January 3, 2006 and July 31, 2006, and a referendum. The tax is ultimately regulated by national law.</p> <p>Congestion tax is charged for Swedish-registered vehicles that are driven into and out of central Stockholm, Mondays to Fridays between 06.30 and 18.29. Some vehicles are exempt from congestion tax.</p> <p>Vehicles are automatically registered at 'control points' during the periods when congestion tax is charged, with automatic number plate recognition (photographs). Each passage into or out of central Stockholm costs SEK 10 (approx. 1 euro), 15 or 20, depending on the time of day. The maximum amount per day and vehicle is SEK 60.</p> <p>The Swedish Transport Agency will send a payment slip to the owner of the vehicle at the end of each month.</p> <p>The island Lidingö has its only access to the mainland through the congestion tax affected area, all traffic to and from Lidingö to and from the rest of the Stockholm County is exempt from the tax, provided that one passes one of the Ropsten bridge abutment (the mainland side of the bridge) control points and some other control point within 30 minutes of each other.</p> <p>The Essingeleden motorway, part of European route E4, that goes through the congestion tax affected area is also exempt, as it is the main route by-passing central Stockholm with no other viable alternatives present in the vicinity.</p> <p>In 2013 we also will use the system with congestion tax in Gothenburg.</p>
6 Evaluation	<p>A series of evaluations were made after the seven month trial period. All showed positive effects of the congestion tax. Traffic and emissions were reduced.</p> <p>The groups of people who in general pay the most congestion tax are men, people with high income, couples with children and people living in the inner city or Lidingö.</p> <p>Both people in general and business representatives have changed their view on congestion tax as the practice has continued from a negative to a positive stand.</p>
7 Lessons learnt from the best practice	<p>People change behavior, and views (!) with time if pushing "the wallet buttons".</p>
8 Contact information	<p>www.transportstyrelsen.se www.stockholm.se</p>
9 Other possible interesting	<p>Links to evaluations : http://www.stockholmsforsoket.se/templates/MakStart.aspx?id=300</p>

information	http://www.stockholmsforsoket.se/upload/Infomaterial%20VV/Faktablad_Eng_Allm_v2_3.pdf
10. Best practice transferred	

Template ITACA showcases		
1	Title of the showcase / best practice	Avoiding rush hour (in Dutch: spitsmijden)
2	Objective of the showcase	The core of the Spitsmijden projects is that drivers are tempted to change their travel behavior by financial rewards. In the region Noord-Brabant participants additionally are rewarded with relevant travel information.
3	Metropolitan region / city	Den Haag, Zoetermeer, Nijmegen, Eindhoven, Den Bosch
4	Owner/executor and participants	Several administrations (national, regional, local) and interest and knowledge institutions
5	Description: - Content and process - Timetable - Finance - Results	<p>Mobilists who are common to drive downtown in rush hour were invited to participate in the project. The participants got a financial reward if they actually avoid driving in rush hour (Monday to Friday 07:30-09:30 a.m. and 04:30-6:30 p.m.) The reward could be €100 maximum in month. Besides the financial reward the participants get a hand held computer with gps, actual traffic information and some other services. The actual behavior of the participants had been monitored by in-car GPS. In recent years several experiments were successful.</p> <p>The actual project in Brabant (with the cities Eindhoven and Den Bosch) has been started in 2010 with 700 participants; another 12.000 potential participants are invited. The project in Brabant will come to an end in 2012.</p> <p>The organizing partners (national, regional and local authorities and several interest and knowledge organizations are positive about the results. Two universities are involved and evaluate the results.</p>
6	Low Carbon Contribution (quantify if possible)	Some mobilists will drive outside rush hour, but also a substantial part chose other kinds transport. The CO2 reduction of the project had to be analysed further.
7	Lessons learnt	This policy of bringing people to the desired behavior seems to be far more easy to introduce than road

		pricing.
8	Other relevant information	<p>Additional information from the website www.spitsmijdeninbrabant.nl</p> <p><i>'The Spitsmijden project in the Netherlands'</i> At several places in the Netherlands last year found that tests are being investigated in any way we can tackle the traffic problem. Spitsmijden has proved a successful formula. The core of the Spitsmijden projects is that drivers are tempted to change their travel behavior by financial rewards or as in-Brabant with relevant travel information.</p> <p><i>Spitsmijden projects in Nijmegen, Zoetermeer, Gouda, Rotterdam, Haaglanden (The Hague region)</i> Very successful was the project Smart Pricing Waalbrug in Nijmegen where 6,000 participants averaged 1,400 cycles per day avoidance realized. During large-scale road works because of this there were hardly any queues at this otherwise busy bridge. Also on the A12 motorway between Zoetermeer and Gouda, the traffic, thanks Spitsmijden, around major road works between 2008 and 2009 within boundaries. Projects currently ongoing or being prepared are: SpitsScoren Rotterdam, SLIM Awards in Arnhem-Nijmegen and Spitsmijden Haaglanden around The Hague.</p> <p><i>Spitsmijden in Brabant</i> Spitsmijden in Brabant is not a trial like any other. This test focuses on urban accessibility and deployment of advanced traffic information on a handheld computer. To test various new information developed. With Spitsmijden in Brabant examines the impact of this information on the travel behavior of participants.</p> <p><i>Great effect</i> Queues as more vehicles over a road like than the capacity of the road permits. It is often the case that a small decrease in the number of cars on the road if it can provide for the collection of files or even its disappearance! This effect is clearly visible in (school) holidays. It only takes a little movement, while the effect on congestion is very high.</p> <p><i>Lasting behavioral</i> Participants in previous projects often indicate that avoiding rush hour so happy that they never would otherwise! Because they save time and less stressful experience for example, but also because they feel they contribute to a better accessibility and quality of</p>

		life in their region.
9	Website	www.spitsmijden.nl www.spitsmijdeninbrabant.nl

BMF/mv/ITACA/Spitsmijden/110209.v01

Free Employee bikes ("Bike Sharing") and repair, plus financial incentives to use trams, Rimini (also in supply/demand)

The bike-sharing systems currently found in the region pertains to the two types listed below: Bicincittà, accessible via smart card and which is inherent in the design of the Emilia-Romagna "I move in Bici" being implemented, and C'entroinBici, a mechanical key. With regard to the first system is currently located in 3 different towns (Guastalla, Parma and Reggio-Emilia) a total of 29 distribution stations, bike seats 311, 173 bicycles, 2,890 issued and 1,584 badges badges activated, the mechanical key system, present in 23 different municipalities (see table below), provides for the availability of 1424 / 2, along with about 2,000 present in many Italian towns, with a participation of over 65,000 users in 97 different cities.

Regionali	
Bologna	184
Bondeno	4
Carpi	40
Casalecchio	16
CastelMaggiore	20
Cesena	64
Correggio	12
Faenza	66
Ferrara	140
Imola	96
Lugo	16
Misano Adriatico	20
Modena	290
Piacenza	48
Polo ceramico (Sassuolo, Maranello, Formigine e Fiorano)	64
Ravenna	180
Regione Emilia-Romagna	28
Riccione	4
Rimini	100
S. Giovanni	20
Zola Predosa	12
Totale	1424

1.2 Land Use Planning Policies



Land Use Transport Interaction Modeling (LUTI)

Section	Indication of content
1 Title of the best practice	LUTI Modeling: Capturing economic and emissions impacts.
2 Precise theme/ issue tackled by the practice	Evaluating the carbon emissions and more fully capturing the economic impacts of various transport and land use interventions to better inform decision makers.
3 Objectives of the best practice	To explore through consultation with experts, the literature and through a case study, the potential of Land Use Transport Interaction (LUTI) models to better estimate the carbon emissions and economic impacts that are likely to occur as a result of changes to the transport system (improved infrastructure and public transport services) and changes to land use resulting from planning. Having better knowledge of these impacts will enhance the decision making process as to which schemes should be funded.
4 Location	South Hampshire, UK
5 Detailed description of the best practice	<p>Origin:</p> <p>Transport models are required to predict future traffic levels, test the impact of new roads, railways, policies etcetera and to determine what transport effects will occur if particular spatial development plans come to fruition. In some circumstances such a transport model might also be used by private developers to determine the impacts of a specific large development.</p> <p>Transport models tend to be regional in size, ranging from one city at the smaller end, to a whole country at the other. Transport models have usually followed a traditional four stage transport model process. This process assumes that land use causes transport; that where particular things are built determines transport flows. These models serve their purpose well in determining the transport impacts of different schemes; however they are not able to model the more complex associations between land use and transport that is thought to exist in reality. In conventional transport models, the land uses are assumed to be fixed, partially due to the difficulties in modelling changes in land uses and gathering the data required to do so, but also in part because the exact mechanism by which the two interact is still</p>

debated. In conventional models this means that improvements to the transport system enabling faster travel are assumed to result in changes in the number of trips, the destinations and routes for each origin. Or, the same trips are made, but more quickly creating travel time savings to the traveller. However, research has shown that the time spent travelling remains fairly constant as a result of improvements to the transport network, thus the result of these improvements is increased mobility. People are able to travel further to access the goods and services they require, at a price they are willing to pay. The greater choice of goods and services available to the traveller can be said to reduce local monopolies and hence drive down costs. How in the medium to long term, businesses and markets respond to such changes in travel times and mobilities is less well understood and difficult to capture in a conventional transport model. It is highly plausible for example that business respond to the increased mobility by agglomeration (for example the growth in out of town retail parks) which in turn would have a considerable impact on travel behaviours. In perfect, unregulated markets, such changes would be relatively straight forward to capture. The relationship is further complicated however by the imperfect nature of land use markets as land use is heavily regulated by policy through planning.

LUTI models try to capture this more complex relationship between land use and transport and in so doing produce a number of different outputs that are of interest. They can model for example the impacts on property prices, industrial competitiveness, migration, etcetera as a result of both particular land use plans and changes to the transport system. They can be used to predict the economic impacts of not only transport schemes but also land use plans in more detail. LUTI modelling has been developed over the last thirty years or so, primarily in the UK but with notable examples elsewhere. The focus of this development has been by industry although examples exist of LUTI modeling or land use transport modeling with land market enhancements to test the sustainability or emissions impacts of different development and transport scenarios such as Cooper et al (2001) and Cooper and Smyth (2001) although the empirical evidence underpinning such models is less well clear, either in the case of the UK or indeed elsewhere in the world (Adhvaryu, 2010). Examples of studies where LUTI models have been used to test future carbon emissions from transport include the Scottish Carbon Footprint project which predicted that compared to 2007, by 2021 emissions from road transport will be approximately 10% higher. Having detailed simulation models that are able to estimate emissions in the future and what influence policy will have on future levels is obviously of critical importance. However examples where such LUTI models have been fully utilised to determine transport carbon intensity measures for new schemes remain extremely rare. This in part is likely to be due to the additional considerable cost involved with developing a LUTI model as opposed to a more conventional transport model and the fact that there is currently no requirement for modellers to consider the issues discussed here in their appraisal of proposed transport schemes. Current guidance on how to appraise the various impacts of large transport schemes is described in Transport Appraisal Guidance (TAG) produced by Department for Transport (DfT). Recognising the potential for LUTI models to enhance the assessment of economic impacts of schemes, the DfT have undergone a period of consultation as to how better capture some of the economic

impacts (TAG Units 3.5.14 & 2.8). These draft documents discuss amongst other things, how the following wider economic impacts of transport schemes might be assessed:

1. Agglomeration Impacts,
2. Output change in imperfectly competitive markets,
3. Labour supply impacts,
4. Move to more or less productive jobs.

It should also be possible to model the knock on effects of the above on travel behaviours and the transport system.

The DfT consultation documents recognise the potential for LUTI models to capture these along with other economic, land use and transport impacts associated not only with improved transport systems but also as a result of development planning.

One example is of a state of art LUTI model currently being developed to test real life planning, transport and other scenarios is that being developed on behalf of Transport for South Hampshire (TfSH). While it is not possible to carry out model test runs within the scope of the TraCit project, the TfSH model provides a useful example of the potential of LUTI modelling to better determine the transport carbon intensity impacts of various interventions.

Timescale:

The model build was due for completion in Spring 2011, approximately two years after the consultants were appointed.

Bodies involved / implementation:

LUTI models are not common and hence it is difficult to draw too many conclusions about a general case in terms of costs and, to a lesser extent, stakeholders. However, transport models are usually developed on behalf of Local Authorities or groups of local authorities. A smaller number of transport models might be commissioned by governments such as the Transport Model for Scotland. LUTI models are no different but perhaps work better at a slightly larger geographical scale than a more traditional transport model and hence are more likely to be commissioned by groups of local authorities or from regional planning organisations. In the past, simpler transport models were more likely to be developed in-house by local authorities, whereas now, most transport models are developed by external consultants. LUTI models are almost exclusively developed by external consultants given their relatively complex and specialised nature. Indeed LUTI models are usually developed through a collaboration of a transport modelling consultancy and a land use modelling consultancy on behalf of the client. These models once developed are then maintained, usually by the consultants, for whatever period is specified and model runs are performed usually by the consultants but in other instances the models are handed over to the clients along with suitable training to maintain and run the model as required. The TfSH model is no different in that it is commissioned by Transport for South Hampshire which is a collaboration between:

	<ul style="list-style-type: none"> • Hampshire County Council • Portsmouth City Council • Southampton City Council
6 Carbon metrics used and why	<p>A suitably specified LUTI model including the TfSH model, can produce total vehicle distances driven, journey speeds, stops, delay etcetera. Given additional information on vehicle fleet combined with information from the Vehicle Certification Agency or by using simple average emissions values for the UK fleet of vehicles, carbon emissions values can be determined for powered road transport expressed in terms of:</p> <ul style="list-style-type: none"> • Transport CO2 emissions/capita, • Transport CO2 emissions/billion passenger kilometre. <p>Similarly passenger count information is available enabling similar simple calculations of the above for bus and rail transport also. Walking and cycling are not captured, and while both modes of transport produce emissions, these emissions are considered to be negligible.</p> <p>Combined with the evaluations of economic impacts discussed, the further metrics can be produced:</p> <ul style="list-style-type: none"> • Change in CO2 emissions/ Change in economic output.
8 Lessons learnt from the best practice	<ul style="list-style-type: none"> • To more fully capture the economic impacts; particularly the impacts in terms of agglomeration, output change in imperfectly competitive markets, labour supply impacts, and move to more or less productive jobs, a LUTI modelling approach is advisable. • Sensitivity analyses or stochastic element could be built into future models to reflect uncertainties in some of the modelling assumptions, including assumptions on national economic growth and migration, which have proved to be inaccurate in the past. • In addition to considering the carbon emissions impacts, the modelling approach allows other noteworthy impacts of transport schemes to be estimated including: • Other vehicle emissions including NOx, which is a particular cause for concern in the South Hampshire subregion, <ul style="list-style-type: none"> Improved diversity of choice, Social inequality and integration, Access to affordable housing. • The additional resources needed to fund the development of a LUTI model as opposed to a more conventional model, may be difficult to justify in a climate of public sector budget cuts, although the potential

	<p>savings or boost to the economy resulting from funding projects based on fuller knowledge of their impacts may well offset such costs.</p> <p>Copies of the presentations made at our workshop regarding best practice in this area are available on the CURE, University of Portsmouth website (See (http://www.port.ac.uk/departments/academic/architecture/CURE/2010/tracit/))</p>
9 Contact information	<p>Contact person: Catherine Teeling, CURE, University of Portsmouth Tel: +44 02392 84 2098 & +44 02392 84 2083, Email: tracit@port.ac.uk, Website: www.port.ac.uk/architecture/research/cure, www.tracit.org.uk</p>
10 Other possible interesting information	<p>Russo, F., Musolino, G. (2007) Urban land-use transport interaction modelling: state of the art and applications. In Urban Transport XIII, Urban Transport and the Environment in the 21st century, Brebbia C.A. (ed.), WIT Press, Southampton, pp. 525-534</p> <p>Feldman, O, Nicoll, J, Simmonds, D, Sinclair, C, Skinner, A (2008): Integrated Transportation Land Use Models for Calculations of Wider Economic Benefits. Paper published in Transportation Research Record, Journal of the Transportation Research Board, No. 2076.</p> <p>Transport for South Hampshire Evidence Base. (http://www3.hants.gov.uk/tfsh/tfsh-what-tfsh-does/tfsh-projects-evidence-base.htm)</p>
11. Best practice transferred	<p>The TraCit project has contributed to the Department for Transport consultation on The Wider Impacts Sub-Objective TAG Unit 3.5.14 (DRAFT FOR CONSULTATION, September 2009, Department for Transport).</p> <p>Project partners at the Cracow University of Technology (CUT) have stated that they will endeavour to incorporate a LUTI element to the sub-regional models being developed in the Malopolska region following on from the presentations given by Professor Marcial Echenique (University of Cambridge) and David Simmonds (David Simmonds Consulting) at the TraCit workshop held in Portsmouth in November 2010 and the presentation and discussions held with Andy Dobson (David Simmonds Consulting) at the TraCit workshop hosted by Cracow University of Technology in May 2011.</p>

LUTI References

Adhvaryu (2010). "Enhancing urban planning using simplified models: SIMPLAN for Ahmedabad, India." Bhargav Adhvaryu. *Progress in Planning* (2010), doi:10.1016/j.progress.2009.11.001.

Cooper and Smyth (2001). "Contemporary lifestyles and the implications for sustainable development policy: Lessons from the UK's Most Car Dependent City, Belfast. *Cities*, Vol. 18, No. 2, pp. 103-113, 2001.

Cooper et al (2001). "Energy Trade-offs and Market Responses in Transport and Residential Land-use Patterns: Promoting Sustainable Development Policy." J. Cooper, T. Ryley and A. Smyth. *Urban Studies*, Vol. 38, No. 9, 1573-1588, 2001.

Scottish carbon footprint: H Gillies, S Cragg, J Davidson, K Lumsden (2006): Land-use and transport integration in Scotland (LATIS): a national carbon footprint. European Transport Conference, 2009, available at www.etcproceedings.org;

STEPS project: Fiorello, D., Huisman, G., López, E., Marques, C., Steenberghen, T., Wegener, M., Zografos, G. (2006): *Transport Strategies under the Scarcity of Energy Supply*. STEPs Final Report, edited by A. Monzon and A. Nuijten. Den Haag: Buck Consultants International. Available at www.steps-eu.com/reports.htm

The Wider Impacts Sub-Objective TAG Unit 3.5.14 (DRAFT FOR CONSULTATION, September 2009, Department for Transport). <http://www.dft.gov.uk/webtag/documents/expert/unit3.5.14c.php>

Wider Impacts and Regeneration. TAG Unit 2.8. DRAFT. FOR CONSULTATION. September 2009. Department for Transport. *Transport Analysis Guidance (TAG)*. <http://www.dft.gov.uk/webtag/documents/project-manager/pdf/unit2.8c.pdf>

APEA canteen

(Primarily used large report as source material. Showcase (only in Italian) pasted in third section below, not here, as it focuses primarily on bike/bus modeshare potential. However, the Canteen land use effect is noteworthy!)

Comprehensive and Environmental Plans, Lidingö, Sweden.
(pre-release summary of process; political delay to August.)

DESCRIPTION OF THE PROCESS OF PRODUCING AN ENVIRONMENTAL PLAN

The main contribution from Lidingö in the ITACA project is to share the experiences of the process in developing an integrated Environmental Plan. Sustainable transport is our major challenge and one of the focus sectors of the plan.

Overview of the project of writing the environmental plan

- 1) Commission from the politicians with instructions for the project
- 2) Setting up an organisation for the project
- 3) Mapping the environmental strengths and weaknesses of the municipality and the island
- 4) Evaluating the main problem sectors and prioritize issues
- 5) Gathering ideas of possible actions and goals
- 6) Setting up an outline for the plan
- 7) Evaluating actions and creating realistic goals
- 8) Referring the goals, main actions and quality audit system for consideration
- 9) Incorporate and evaluate the incoming views in the final plan
- 10) Final political decision about an environmental plan
- 11) Kick off the environmental work!

The project has had a participative approach and representatives from those affected by the work have been actively involved during the whole process.

The aim of the plan is to handle both internal (within the organisation) and external issues (with other actors involved).

Background and commission

Lidingö is a suburb located on an island, only a couple of kilometres from the Swedish capital of Stockholm. A bridge for cars, bikes and trams is dividing the municipality from Stockholm. Due to its closeness to the capital, Lidingö has turned out to mainly be a place for living while working in Stockholm. This means that the commuting rate is high, mainly from the island but also to the island. Due to the geography, no heavy traffic is going through the municipality. The island hardly hosts any industry and the main employer in Lidingö is the municipality itself.

When addressing environmental issues it is therefore logical to concentrate on the environmental impact of the organisation of the municipality and also on the behaviour of the citizens.

Sweden's environment policy is based on sixteen environmental quality objectives for different areas. The objectives describe the quality of the environment that we want to achieve. Based on these objectives the regional level is supposed to set interim targets and specific goals, it is voluntary for the local level. There is no system to set the objectives so municipalities use different ways, this follows the principals of a decentralised state.

A municipality in Sweden has great opportunities to reduce the environmental impact from the internal organisation but also to give good conditions to the society in general to reduce it's impact. The municipalities are responsible for, among other things; primary and secondary school, elderly care, roads and traffic situations, waste and sewage, parks and nature etc.

The Lidingö Municipal Executive Board commissioned the Executive Office to lead the process of developing environmental goals and an environmental quality audit system that included internal as well as external aspects.

Organisation of the project

The project organisation has been built, based on a participative approach. The collaboration process was imperative to the result.

A project leader from the Executive Office was responsible for the project. A local project group, with representatives from all departments, was appointed. A Steering Committee composed by the Head of Environment and Urban Planning Department, Deputy City Manager and Head of Property Management Department, met approximately once a month, controlling the project and making sure it was on a prioritized agenda.

Mile stones in the project have been communicated with a broader project group.

The point of departure resulting in an integrated approach

An environmental mapping was made in 2009, the mapping as well as workshops during the initial period led us to the decision that the Environmental Plan needs to have an integrated approach.

The mapping and workshops showed that the municipality could cooperate better internally and render more environmental effective. Up to this point different committees and departments of the municipality worked towards different goals and sometimes the goals could even be conflicting. Hence the internal work had to be more strictly governed and the goals had to be integrated and common for the whole organisation of the municipality.

Concurrently concerning the external communications and actions (principally towards the citizens), experience and science about behavioural change showed that behavioural change is intensely connected to identity making. The vision for the project was that all small environmental efforts in everyday life shall come together to an identity – a way of living environmentally smart. This vision had to start modestly with an integrated plan that painted the common picture.

The mapping showed that the major environmental problem in Lidingö is the traffic situation. At the same time this is the problem that the city has the greatest possibilities to solve. Other challenging sectors were energy savings in housing, recycling and sustainable consumption. Behavioural change is therefore at the core of the plan.

An integrated approach means that we can address the transport problems from different perspectives and therefore reach different actors more effectively. Instead of structuring the work according to the city's old organisational traditions or using the structure of the professional environmentalist we use an approach which is hopefully more intuitive to the actors involved. For example, in dialog with the

citizens we talk about their every day life and how the local authority can make it easier for them to make environmental friendly choices, this means that recycling and cycling can be addressed on the same occasion. It is important that we as a local authority talk with one voice.

Evaluating and prioritizing

A model of evaluating was used in a large group (project group, steering committee, broader project group) to prioritize the different environmental issues that were revealed in the mapping. The model includes a judgement of the seriousness/danger of the impact combined with the scope of the impact. It was made on a relative scale (e.g. among the issues concerned to Lidingö). The scale has a wider spread on danger than on scope, in order to avoid that very dangerous impact could be neglected. The evaluation is subjective and of course needs additional discussions.

The scale can be described as follows:

Danger 1 – 6

- 1=safe
- 2= relatively safe
- 3=rather dangerous
- 4=dangerous
- 5=very dangerous
- 6=extremely dangerous

Scope 1 – 3

- 1=small
- 2=average
- 3=large

The two figures thereafter are added for a total value. Everyone first made an individual assessment and thereafter the group made a common assessment. A map over the different issues could then be drawn with scope on the x-axle and danger on the y-axle.

Transports	Green house gases from transports	9
Energy	Energy savings	9
Waste	Reduction of waste	8,5
Energy	Green house gases from housing	8
Public procurment	Reduction of dangerous matters	8

Land use and water	Demands when utilize of land	8
Transports	Noise from transports	6
Waste	Dangerous matters, emissions to land and water	6
Land use and water	Degeneration of Nature recovering	6
Public procurement	Green house gases emissions	6
In door env.	Moisture and mould	6

Table. The process first identified sources of GHG emissions. Transportation was the top offender

Gathering ideas for actions and goals

The members of the project group assigned small working groups in their departments to work out ideas for actions and goals. The ideas were then presented to the project leader and project group.

The project group also had different seminars with external expertise for inspiration.

Two workshops were held with the broader project group, through different brain storming exercises, actions and goals were singled out.

Meetings were also conducted with the civil society. For example with; the Lidingö Branch of The Swedish Society for Nature Conservation; the municipal Business Committee; one association of house owners. A questionnaire, based on the list of actions from the project workshops, was given to citizens visiting the City Hall's Open House.

A big workshop was conducted with the target group of local politicians; Chair and Vice Chair of all the municipal Committees. The workshop gave the project great political input. One aim was also to inspire and enforce the political arguments by facts, hence an external expert was invited to give the audience the reasons to act on environmental issues. Climate Change was in focus. The Mayor for Environment and Transport in the City of Stockholm was invited to present the experience of Stockholm.

The outline

Three strategies or visions were put forward after workshops with officials from all departments, during late spring 2010. The three headlines were drafted as:

- Energy Smart City
- Sustainable Green Island
- Eco-wise Choices

The local Project Leader and Steering Group came up with a first proposal for classification and selection of detailed goals and activities, based upon the results of the participative process that had been taking place. The proposal was based on an outline with the three headlines. Under each headline a short passage with a vision for 2020 is written and subsequently three to four goals to reach before 2015. All goals are illustrated of main actions.

The plan for consideration

A proposal for a plan was processed within the organisation first and then with the political majority. Thereafter the Municipal Executive Board decided to refer the plan for consultation; to the other political parties, national and regional authorities, local associations, local business and citizens.

The final decision

After incorporating the incoming views to the plan a new proposal was sent to the Municipal Executive Board. The final decision is planned to be taken by the Municipal Council on 29th of August.

Kick off

After the plan is decided upon, the most important work will start – the actual actions for the environment! To ensure that the work will be coordinated and that all the committees will work for the goals, the City Executive Office will employ an Environmental Coordinator. The first task of the coordinator is to make sure that the Environmental Plan is incorporated in the budget for 2012, in all the committees. The coordinator's first actions will also be to raise the awareness of the plan and the environmental knowledge in general, both within the organisation and externally.

The biking campaign - a sample of the actions in the coming plan

The Lidingö contribution to the ITACA- project is first and foremost the participative process of producing an environmental plan. One action connected to the plan and to ITACA is the bicycle campaign that took part in May this year.

The biking campaign took place after the plan was sent out for consultation and was the first action that was communicated in connection to the plan. It was an appetizer or a sample of the new way of working with these questions! (See our article on the campaign in the latest newsletter.)

1.3 Transport Supply/Demand Management

Template ITACA showcases		
1	Title of the showcase / best practice	Green Parking at Hot Spots
2	Objective of the showcase	<i>Heart of the matter:</i> free parking at parking hot spots with green-label (most eco-friendly) cars. (Hot spots: city centres or near entrances of companies.) Additionally: some of these parking places could be provided with (quick) charging facilities for EV's.
3	Metropolitan region / city	In the Netherlands: no information available yet about locations with this facilities. (GPI has been asked to send us information about the progress the made.) The city of Avignon (France) has introduced this kind of system in Januari 2011.
4	Owner/executor and participants	SundayAfternoon, Instituut voor Duurzame Mobiliteit/Duurzaam op weg.
5	Description: - Content and process - Timetable - Finance - Results	Cars with the lowest CO2-emission in their category could applicate for a badge with which they are allowed to use for free attractive parking places at highly attractive locations. The administrative system behind this allowances is based on a CO2-emission indexation of cars. It is the responsibility of companies and local authorities to create the special parking facilities at the most wanted locations. In the Netherlands the CO2-emission index of cars exists and at the moment is primarily used for a tax relieve system by the national administration, introduced in Januari 2010. Cars certificated as most-energy efficient in their category are A-labeled. A-label cars get 100% tax relieve on purchase and lower use-taxes. are free of tax relieve on purchase and use tax. (Sales reports for 2010 show an important increase in the purchase of smaller fuel-efficient cars.) The Green Parking Initiative stimulates local authorities and companies to create free parking places at hot spots for low-emission cars with an GPI badge and invites drivers to order the GPI badge. GPI provide some tools for authorities and companies to create and mark the green parking places, the distribution of badges and providing a GPI-locator for mobilists.
6	Low Carbon Contribution (quantify if possible)	GPI is one of the incentives to buy and use low-carbon cars. The isolated effect is hard to predict.
7	Lessons learnt	
8	Other relevant	GPI is a very transparent system, easy to communicate to the

	information	<p>public and could be helpful to create public support to eco-friendly transport policies and a 'green' imago of firms and local governments.</p> <p>The system is very easy to applicate and doesn't require new research, complicated administrations or high costs. The explotation could be cost-neutral to governments (costs could be covered from other the parking places.) The system could be introduced in whole EU without complex regulation and administrative complications.</p> <p>There is one point of hesitation at the moment: there is lack of experience. Explanation: the number of green cars is rather small; administrations and companies are not pushed to create green parking places yet. We expect this will change soon.</p> <p>There is another important reason to create green parking facilities as soon as possible: they are very appropriate as charging facility for EV's. This also opens opportunities to invite electricity providers to participate in this initiative.</p> <p><i>Recent information from the inventors:</i> "The Green Parking Initiative is currently in the pilot phase. We are now rounding up this phase and making up our minds on how to proceed next. I think it is the right time to open the discussion with other parties and I'm interested in meeting up to discuss a possible future together.</p> <p>The initiative was started by the Institute for Sustainable Mobility and Sunday Afternoon as a means to promote sustainable driving in a emotional way. Many initiatives focus on either technology or money. We think that by appealing to a sense of "exclusiveness" we can contribute to a change in behaviour.</p> <p>Currently we have a very small amount of parking spots and a handfull of drivers that have obtained the GPI-label. This result is quite good if you consider that we had no PR or campaign. We think it might catch on if we would scale up the initiative. The original plan is to involve car dealers in this picture to distribute the GPI-labels with their newly sold cars. Companies and local governments are asked to join the initiative and provision about 10% of their parking space.</p> <p>In Zeist, Amsterdam and Nieuwegein we have parking spots available. We are now discussing the idea to create some GPI-spots at a large national event to scale up things. The best case is found at Bizon in Amsterdam. This company has bought some sustainable vans and created a GPI-spot to show this to the local government and their clients."</p>
9	Website	www.greenparkinginitiative.com



BMF/mv/ITACA/GPI/110208.v02

Sustainable Urban Mobility Plans (SUMP) for the Province of Huelva



Diputación de Huelva

Executive Summary

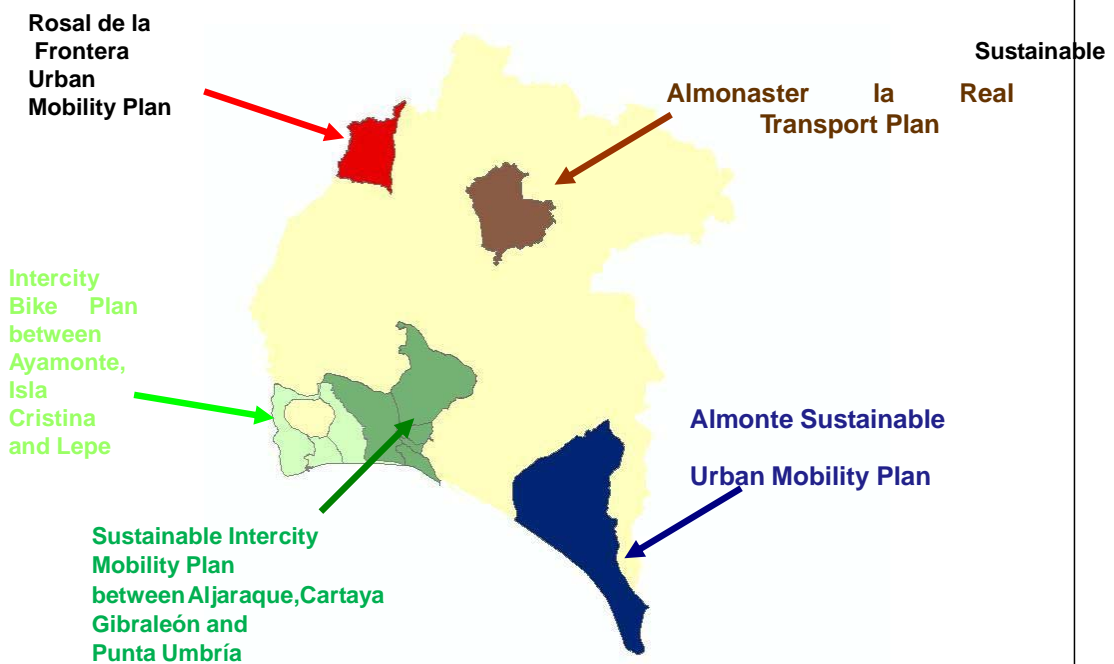

POWER
Low Carbon Economies



European Union
European Regional Development Fund



INTERREG IVC
INNOVATION & ENVIRONMENT
REGIONS OF EUROPE SHARING SOLUTIONS



Agencia Andaluza de la Energía
CONSEJERÍA DE INNOVACIÓN, CIENCIA Y EMPRESA

INTRODUCTION

The current mobility in Spain, particularly in the municipalities of the province of Huelva, is characterized by its strong dependence on private vehicles, the result of urban planning strongly scattered, especially in the last two decades (urban sprawl) as well as low competitiveness of public transport, aimed at captive users (who have no private vehicles) and no safe and comfortable non-motorized routes. Not forgetting also that psychological considerations of social status or personality associated with vehicle ownership is still deeply rooted in Spanish society. As an example, in the province of Huelva in recent years population growth stood at around 1.5%, while increasing its fleet has grown to figures around 12%.

These mobility patterns result in a high energy consumption (non-renewable fossil fuels) and some environmental impacts (GHG emissions and local pollutants effect) that reduce the quality of life in urban areas and the health of people.

To reverse this trend it should be encouraged an urban transport system more equitable (better distribution of urban land among the various modes of transportation) and environmental friendly. To achieve this it is necessary to implement measures and change trends, so it is necessary social awareness and involvement and cooperation of the authorities to achieve solutions that improve mobility at social, economic and environmental level, pillars of sustainable mobility.

MAIN OBJECTIVES

- Regulate **and control the access and parking** in urban centers.
- Enhance **park and ride** to promote intermodality.
- Develop and improve the offer of **different transport modes**.
- Develop institutional actions, integrating principles and operation of different **public transport** systems, therefore improving the intermodality of them.
- Mobility management, particularly in large **attractors centers**.
- Encourage **bicycle and pedestrian mobility**.
- Establish and exploit the primary **road network** for different transport modes.
- Improving **urban freight logistics** (loading, unloading, distribution, etc.).
- Saving **energy** and improving **environmental quality**

In this context, and considering the demand requested by various municipalities in the province, Diputación of Huelva have launched initiatives aimed at improving mobility, both locally and intermunicipally through the development of competitive alternatives to the use of private vehicle leading to the reduction of its excessive use.

All of them are included in the **Sustainable Urban Mobility Plan of the Province of Huelva**, which includes performances in the municipalities of Aljaraque, Almonaster la Real, Almonte, Ayamonte, Cartaya, Gibralfaró, Isla Cristina, Lepe, Punta Umbria and Rosal de la Frontera, being broken down as follows:

Joint Actions:

- Intercity Cycle Mobility Plan of Ayamonte, Isla Cristina and Lepe municipalities.
- Sustainable Intercity Mobility Plan of Aljaraque, Cartaya, Gibraleón and Punta Umbria municipalities.

Individual actions:

- Sustainable Urban Mobility Plan of the municipality of Almonte.
- Sustainable Transport Plan for Villages Township of Almonaster la Real.
- Sustainable Urban Mobility Plan of Rosal de la Frontera Township.

PROCEEDINGS

The work done in the Sustainable Urban Mobility Plan of Huelva Province were developed following a series of phases that are shown graphically in the figure below:

SUMP project phases of Huelva Province

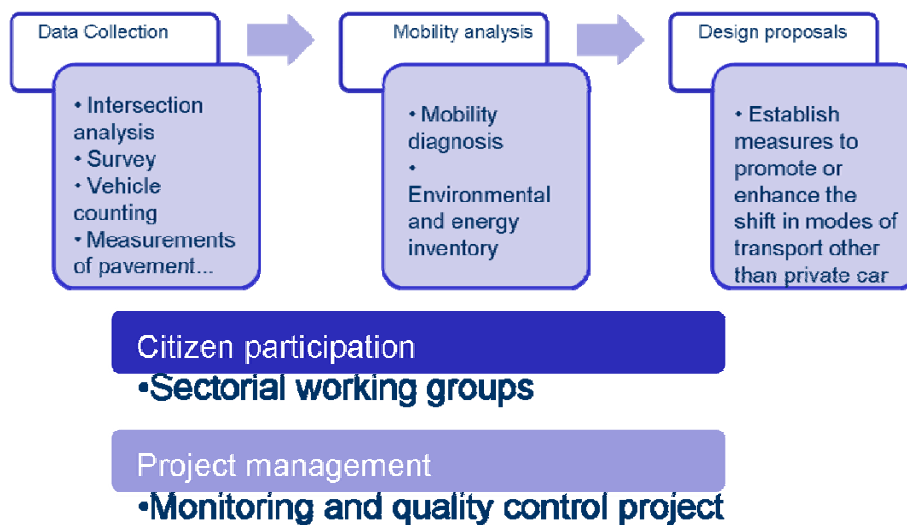

Scheme developed in the development stages of Huelva Province SUMP

PLAN ANALYSIS, DIAGNOSIS AND DEVELOPMENT

In the analysis and diagnosis phase major mobility patterns for all areas covered by this study have been identified and analyzed, both in terms of supply of transport (infrastructure and existing services that enable the movement) and transport demand (use that citizens make of that infrastructure and services). For this we have previously developed a fieldwork campaign, highlighting the following measurements in each municipality under study:

- Geometric and functional characterization of urban and interurban **road network** and daily light and heavy traffic intensity gauge .
- Identification and occupancy throughout the day. of existing **parking** areas .
- Definition of the **public transport** systems operating in various municipalities.
- Detection and characterization of the existing **pedestrian and bicycle** infrastructure.
- Location of existing areas for **delivery, loading and unloading of goods**.
- **Population surveys Campaign** to understand their mobility patterns, reasons for using / not using the various possible travel modes to detect problems in their daily mobility and willingness to take part in potential proposals for action.

The subsequent processing and analysis of data produced by the field work campaign has resulted in the analyzed municipalities Mobility Diagnosis.

Once characterized the mobility current state a set of policy proposals has been designed aiming at mitigation of identified problems in the diagnosis.

Below the main findings of Diagnosis and actions according to the 5 studies forming the SUMP for the Province of Huelva:

- Cycle Mobility Plan of Ayamonte, Isla Cristina and Lepe municipalities

OBJECTIVES

This Plan seeks to encourage the bicycle mobility to local and county level. Since they are municipalities in the western end of Huelva coast (67 544 inhabitants in 2009), such actions have a strong touristic interest. Therefore it implies a potential reduction of motor vehicle journeys and a boost to cycling because of the enormous natural attraction of the region.

DIAGNOSIS

Currently the problems associated with cycling to local and regional level are:

- Poor general condition of the existing cycling infrastructure at the local and long distance, especially in the case of Ayamonte and Lepe.
- Lack of bicycle parking, which reduces the feasibility of cycling because of non-availability of parking points.
- No public bicycles loan systems, thus preventing disengagement of bicycle travel on bicycle ownership.
- With regard to cycling, is very marginal, restricted only to sport and leisure, so far no offers an alternative to car use at local or county level.



From left to right existing cycling infrastructure in Ayamonte, Isla Cristina, Lepe and greenway between Ayamonte and Lepe

ACTIONS

The proposed actions are intended to facilitate travel between the three towns by bicycle to reduce the current reliance on private vehicles and further promote cycling as a means of attracting visitors.

- Creating local cycling infrastructure** (municipal) in order that all the population centers of each municipality are connected with the main one.
- **Creation of intercity cycling infrastructure**, so that all municipalities, and all the villages that form it, are linked together through safe and comfortable bike lanes.
- Implementation of a supramunicipal public bicycle loan system** to facilitate the use of it among the population that lacks it or is in poor state of repair.
- Implementation of bicycle parking** for users of private bicycles have nearby points to park on both the destination and origin for each journey they make.

It is estimated that all these actions will **reduce energy consumption and emissions figures by around 15%**, thanks to the influence of these actions in the region tourism.

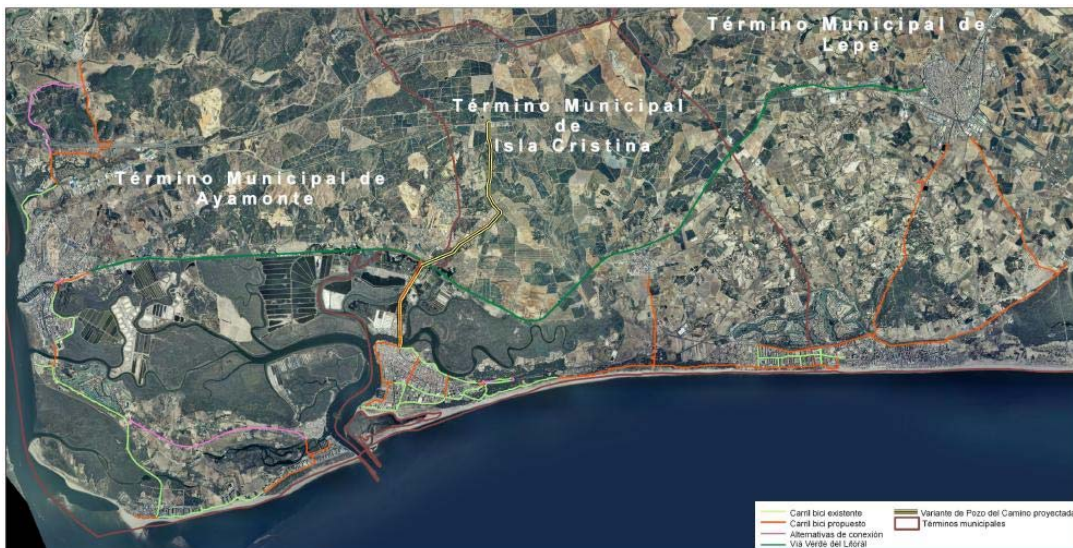

Set of local bike paths and inter-connection between Ayamonte, Isla Cristina and Lepe

- Sustainable Mobility Plan of Aljaraque, Cartaya, Punta Umbria and Gibraleón municipalities

OBJECTIVES

This Plan aims to reduce dependence on private vehicles in the western metropolitan area of Huelva city (62,831 inhabitants in 2009), through the improvement of connectivity through public transport, car sharing and building of protected cycle routes between all four municipalities.

DIAGNOSIS

Currently, the main mobility issues to travel between those cities are:

- Not competitive public transport offer: timetables do not cover peak periods, low frequency, especially in summer period and almost exclusive use by captive users.
- Shortage of non-motorized connections between municipalities and poor maintenance of local roads. Discontinuities in the coastal line connections.
- Marginal car sharing Use , only by individuals who share, and therefore without web platforms that manage or support.
- Lack of bus lanes to segregate traffic problems from the service travel times, especially on routes with origin / destination in the Capital (Huelva).

CARTAYA-ROMPIDO-EL PORTIL-PUNTA UMBRIA

Salidas de Cartaya		
LAB	SAB	DOM
9.15	9.15	9.15
17.00	17.15	17.15

Salida de P. Umbria		
LAB	SAB	DOM
7.35*	9.45	9.45
17.45	18.00	18.00

**Solo llega a El Portil

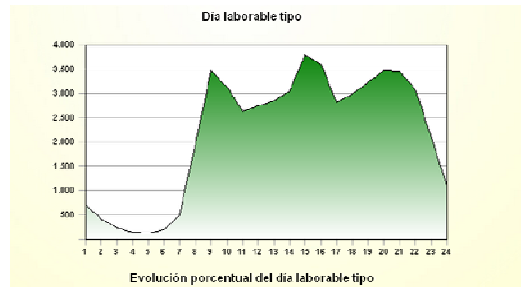

Public transportation schedules between Cartaya and Punta Umbria (left) and evolution of the IMD (50,000 veh) in the A-497 Huelva - Punta Umbria in 2009 (right)

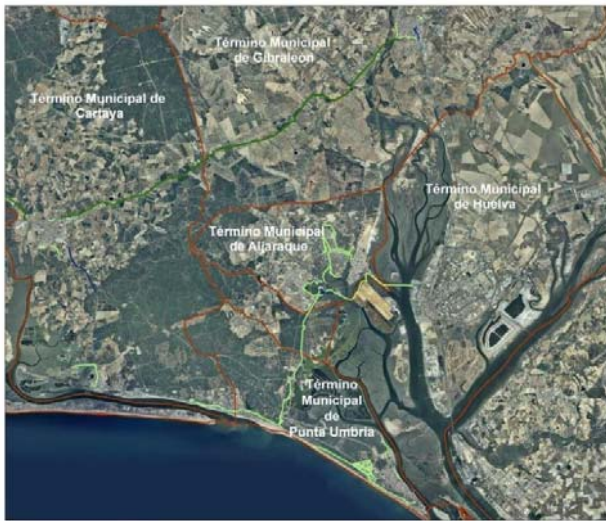

Cycling infrastructure in the municipalities of Aljaraque, Cartaya, Punta Gibraleón and Umbria

ACTIONS

The proposed actions are intended to facilitate travel among the four municipalities analyzed by encouraging alternative travel modes to the low occupancy private vehicle, adapting to the changes in travel demand, especially in summer.

Creating local cycling infrastructure (municipal) in order that all the population centres of each municipality are connected with the main one.

Creation of inter-city cycling infrastructure so that all municipalities are linked together through safe and comfortable bike lanes. Also in this way the non-coastal municipalities (Gibraleón, Aljaraque and town of Cartaya) will have access by bike to the coastal area. Also be provided a link from all municipalities to the bike path that leads to Huelva.

Implementation of a supramunicipal public bicycle loan to facilitate the use of it among the population that lacks it.

Improving public transport services so as to increase the peak hour services, encouraging the use of bus for commuting.

Creating a **shared car platform** to increase the private vehicles occupancy for travelling between the four municipalities as well as Huelva capital.

All these actions will **reduce energy consumption and pollutant emissions figures close to 18%**, thanks to very possible influence of these actions in the movement to / from Huelva capital.

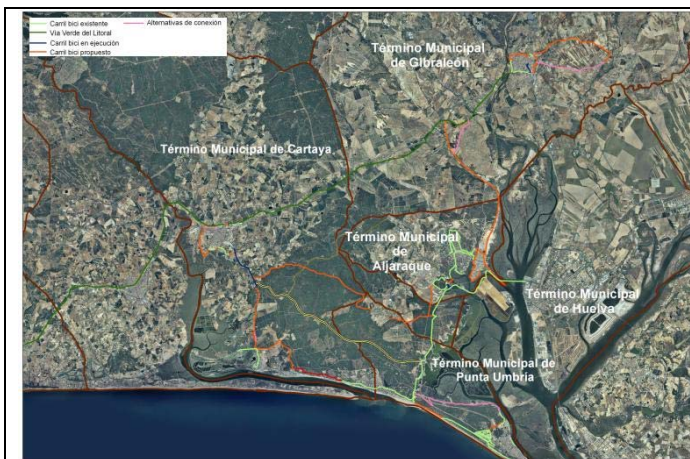

Set of local and inter-city bike paths between Aljaraque, Cartaya, Punta Umbria and Gibraleón

- Sustainable Urban Mobility Plan of Almonte

OBJECTIVES

This Plan aims to improve urban mobility globally in the town of Almonte (21.782 inhabitants, 2009). It aims to promote alternative non-motorized modes and public transport at Almonte town level, as well as more efficient sort of internal displacement in El Rocío village and reduce domestic private vehicle traffic in Matalascañas Beach, the main coastal town of the province.

DIAGNOSIS

While the town radial structure enables local pedestrian movement in almost all of it, the use of private car is widespread, as follows:

- A very prominent use of private vehicle (49% of all journeys, > 600 veh/hour at rush hour). Affected by congestion associated with Matalascañas city bus in summer.
- Lack of public transport in Almonte town (there was a bus a few years ago but was removed (lack of use)
- Lack of parking in the town center, especially in summer in Matalascañas, despite the many existing parking stock.
- Almonte cruise (the busiest street in town) with congestion problems, double rows of parked cars and goods delivery operations in not allowed places.
- Shortage of cycling infrastructure, especially in the urban area of Almonte.
- Lack of people awareness in terms of sustainable mobility (49% of drivers do not travel on foot because the private car comfort).



Traffic intensity in the primary road network in the town of Almonte

All these problems involve a more than **3,000 m³** per year of fossil fuel consumption due to mobility in Almonte. Equivalent CO₂ emissions of nearly **7,800 tons per year**.



Two aspects of mobility patterns of Almonte people: Trip purpose-80% work(left) Perceived problems-parking-58% (right)

ACTIONS

The main actions proposed in the Sustainable Urban Mobility Plan of Almonte aim to encourage internal non-motorized in each of the three town centers in no summer time (Almonte), summer (Matalascañas) and in pilgrimage days (El Rocío).

Almonte

Improved Almonte's road network (Santa Ana Street redevelopment, implementation of traffic calming elements, improving signage, building a gazebo next to the industrial estate). This will lead to a more consistent management and a reduced incidence of road unsafety.

Improved **parking management** through pricing in the downtown area and create rotating parking for residents along the perimeter of this area. Creating an **urban public transport service** that links together the central and the crossing with the main residential areas.

Caution signaling of cyclists on the road presence and Implementation of a **sidewalk bike** along the journey (El Rocío Road) to encourage walking in the urban core.

School paths design to promote pedestrian movement to them.

El Rocío

Improved **signage of routes** in the village.

Pedestrianization of the Plaza del Real (El Real Square) with a consequent increase in occupancy and traffic safety .

Creating a cyclists and pedestrians **green road** connecting Almonte and El Rocío.

Matalascañas

Street resurfacing and adaptation of **ridges and raised crosswalks** to current legislation. **Internal signal Plan** with clear indication of main areas and attractor points of the town.

Parking regulations by charging in areas with more attractor character, in order to reduce the pressure of private vehicle in them.

Implementation of a **Green Way** aimed at cyclists and pedestrians between El Rocío and Matalascañas and expansion of bike lanes to the west of the town.

It is estimated that all these actions will **reduce energy consumption and pollutant emissions** resulting from motorized mobility values that could reach **20%**. Besides the congestion reduction will lead to improved citizens life quality.



From left to right: urban public transport proposed in Almonte, pedestrian plaza of El Real in El Rocío and expansion of bike lane , Matalascañas.

Sustainable Urban Mobility Plan of Rosal de la Frontera

OBJECTIVES

The main objective of this Plan is to promote a less dependent on private vehicles mobility, primarily for the pedestrian mobility, given the small population of the town (1,879 inhabitants, 2009). In addition there is a need to reduce motorized traffic , since the town is near the border with Portugal and also suffers a high rate of heavy traffic.

DIAGNOSIS

The main mobility problems in Rosal de la Frontera are:

- Regular use of private vehicles (over 75% of commute travel a distance of less than 1,000 m).
- High rate of heavy traffic passing through the town crossing (peaks of up to 60 trucks per hour), causing a serious problem of road safety and reducing quality of life (noise, unsanitary conditions by trucks passing to the Nerva's hazardous waste landfill).
- Sidewalk illegally parking at the crossing, the main attractor point of the town. This reduces the competitiveness of pedestrian movement and even reduce pedestrian safety in many cases by forcing them to travel on the road.
- Public transport uncompetitive (only two daily services to Aracena and one to Huelva).
- No cycling infrastructure, because the terrain conditions clearly to this mode of transport.



Traffic intensity in the primary road network in the town of Rosal (left) and parking on the crossing pavement (right)

ACTIONS

The main actions proposed in the Sustainable Urban Mobility Plan of Rosal de la Frontera aim to reduce the problems associated with passing traffic through the crossing of the locality as well as promote non-motorized mobility in internal movement:

Construction of a **bypass road** to eliminate light and heavy traffic crossing through Rosal. The goal is to eliminate the serious road safety problems faced by citizens in the main thoroughfare of the town.

Implementation of plants along the journey on both sidewalks as **barriers to parking**. In addition to this, pedestrian crossing will be channelled by the zebra crossings, increasing road safety for them.

Increased **public transport** service to Aracena (Country hospital) as well as to Huelva, in order to reduce dependence on private vehicles in such journeys. Awareness campaigns designing on the benefits of **pedestrian travel** and safer school paths.

Implementation of a 7 Km long **green path** aimed to cyclists and pedestrians linking the town and San Isidro Park, where the shrine of pilgrimage is located having traffic, especially during weekends.

Implementation of a **car-sharing platform** that allows to manage the application and operation of the car shared, for any long distance travel.

It is expected that all these actions reduce at least 15% of motor transport harmful gas emissions in Rosal de la Frontera. This benefit is even greater given that much of this traffic is passing through the crossing, traffic is to be avoided.



Proposed route of the ring (left) and green path to San Isidro Park (right)

Transportation Plan Almonaster la Real -Villages

OBJECTIVES

Almonaster la Real is a municipality belonging to the Sierra de Aracena y Picos de Aroche region, characterized by the many villages that form its municipality. The municipality of Almonaster la Real (1,848 inhabitants, 2009) has 14 villages- where living together more than 600 people- and core town (Almonaster). The objective of this Plan is to improve mobility between villages and main town, in order to provide alternatives to the use of private vehicles. Main travelling are for going to the doctor and the bank (especially elderly) as well as shopping and work .

DIAGNOSIS

Currently mobility between villages and the core of Almonaster la Real have following problems:

- The use of private vehicles is almost 100% due to the absence of alternatives.
- The type and condition of many of the roads that link villages to each other and Almonaster are deficient (narrowing, poor condition of the road).
- Overall absence or poor state of calm traffic items in the villages.
- Public transport is not competitive (stops are more than 1 km of some villages, no service in other, frequency of one travel per day). Only two taxi licenses.
- The use of car sharing is still marginal.
- Non-motorized mobility is not feasible because of the distances (nearest village no less than 4 km from Almonaster) and the terrain.



Road narrowing (left) and bus stop away from town(right)

ACTIONS

The main proposed actions in the Transportation Plan of Almonaster's Villages are in the line to facilitate travel between the population least likely to have vehicle, which in turn will promote the use of these options also among non-captive users:

Implementation of a public transport system between villages and Almonaster through the **school bus**, so as to optimize the occupation of the vehicle, allowing the service profitable.

Creating a system with 4 **zonal Teletaxi** adapted vehicles, so as a complement to the above proposal may be requested a taxi to travel or return between the villages and Almonaster via telephone and Internet. Being zonal, you can manage the sharing of it, further reducing waiting and travel times.

Implementation of a **car-sharing platform** that allows to manage the application and operation of car sharing, for any type of movement between villages and Almonaster. **Improvement of roads** linking villages and Almonaster to improve current road safety. It is expected that all these actions reduce the dependence on single occupant private vehicles and enable the elderly population to move regularly safe and comfortable from the villages to Almonaster,. **Estimated energy savings and emissions by around 12%.**

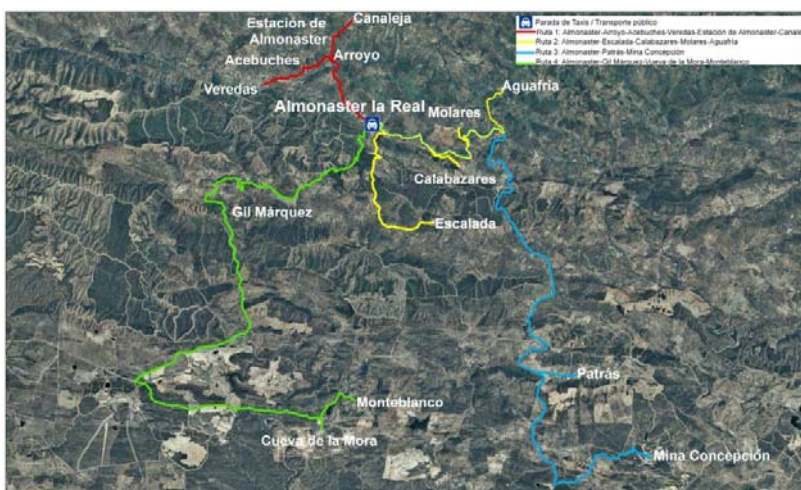

Proposed Public transport system zonal routes in Almonaster la Real

Template ITACA showcases Bicycle paths		
1	Title of the showcase / best practice	To increase the number of bicycle paths in the Province of Rimini. In particular, in the last three years a new path has been realised by the Via Marecchiese, a road connecting Rimini to Novafeltria, by separating the cars' roadway from the bicycles' path. The same thing has been done on the Via Montescudo, between Rimini and Montescudo and Rimini and Coriano. The total length of the path is around 12 km. Furthermore, is in development stage a new path, for bikes and

		pedestrian along the banks of the river Conca, a well known naturalistic area.
2	Objective of the showcase	To increase bicycles mobility and to make it safer.
3	Metropolitan region / city	Province of Rimini
4	Owner/executor and participants	Mentioned cities and Province.
5	Description: - Content and process - Timetable - Finance - Results	<p>Started in 2008 and concluded in 2010 (excluding the project involving the Conca river)</p> <ul style="list-style-type: none"> • S.P. Montescudo - Euro 1.297.000,00 (di cui Euro 490.000,00 – fin. Provincia di Rimini) • S.P.31 - Euro 1.000,00 (di cui Euro 258.229,00 – fin. Provincia di Rimini) • S.P. 258 Euro – Euro 2.477,500 (di cui Euro 100.000,00 – fin. Provincia di Rimini) • S.P.50 – Euro 135.000,00
6	Low Carbon Contribution (quantify if possible)	We have not indicator to give important information
7	Lessons learnt	Improvement of existing practices
8	Other relevant information	---
9	Website	http://www.piste-ciclabili.com/provincia-rimini http://www.provincia.rimini.it/progetti/mobilita/quaderni/q_07/quaderno/index.htm

Free Employee bikes ("Bike Sharing") and repair, plus financial incentives to use trams, Rimini (also in supply/demand, see above or see in Innov Tech. Or duplicate showcase?)

Template ITACA showcases		
1	Title of the showcase / best practice	Public Transport Bike (OV Fiets)
2	Objective of the showcase	Making train travel more attractive by offering cheap, automated, fast and easy-to-use rental bikes at Dutch railway stations.
3	Metropolitan region / city	Over 200 railway stations in all major cities
4	Owner/executor and participants	Invented and introduced by the Fietsersbond (an NGO for bicyclists) and ProRail, company responsible for building and maintaining the Dutch railway network.
5	Description: - Content and process - Timetable - Finance - Results	<p>OV Fiets is an automated bike rental service, to which train travellers can subscribe. Subscription is cheap and the system works with internet and an electronic id-pass, making it fast and easy to use.</p> <p>Started in 2004 with 800 bikes on 70 locations with 11.000 subscribers it has grown to 200 locations with 4.500 bikes and 67.000 subscribers in 2009. Remarkably, without any marketing budget.</p>
6	Low Carbon Contribution (quantify if possible)	On average, CO2-emissions for train travel are three times lower as car travel.
7	Lessons learnt	A good product (fast, easy, affordable) like this does not need big promotion budgets, it taps in on an existing need. Stakeholder participation and involvement (Biker's association and others) delivers benefits and better quality.
8	Other relevant information	Also makes heavy use of ICT. See also the annex: The success of the PT-bike.
9	Website	http://www.ov-fiets.nl/home



The success of the PT-bike (OV-fiets)

It goes well with the OV-bicycle. Five years ago, this initiative started as a pilot for the personnel of ProRail, the initiative now has 20,000 cardholders. And this no marketing budget! What are the success factors?

Origin idea

Over 30% of rail passengers to make the transport from home to the station using the bike. When egress is only 10%. A bike train is possible, but this is complicated and takes up a quarter soon. This should be more easily thought of ProRail. "The OV-bike is a bit of the easyJet of public transport," said Marc Martin, director of the foundation OV-bicycle. By clever use of the Internet and scanners to determine who is right when the bike rental. "Within one minute you stand outside again, with a simple city bike," says Martin proudly. The OV-bicycle is designed for distances between 1 and 5 km.

86 Locations

The OV-bicycle is rented at 86 locations, with stalls manned and automatic OV-bicycle lockers. The cost of the OV-bicycle are similar to the bus. For 2.75 euros you can rent a bike for 20 hours. Payment is by direct debit post.

Authorities discover

Research shows that 36% of cardholders faster the train. 12% take public transport with cycling even the train instead of the car. This also has not escaped public. "Governments are the OV-bicycle by the discovery," Martin points out. He hopes that governments help in finding new rental locations. Finding good locations is a problem.

Doubling

In 2005 the number of journeys has almost doubled over the previous year. And that without any advertising budget. Martin's hopes for 2006 nearly doubled again to 350,000 trips. The ultimate goal is 1% of egress. This represents approximately 2 million trips per year.

Success factors

According to Martin, there are four factors that contributed to the success of the OV-bicycle. First, they start to represent the users Cyclists fetched. This association could indicate exactly where the egress lacking. Subsequently, the promoters of their needs quickly, easily affordable and good product knowledge to translate. A third success factor is good involvement of actors that have interests in the public transport bike. This ranged from ProRail and NS to municipalities. Finally, intensive use of the opportunities offered by ICT.





APEA SURVEY



PROVINCIA
DI RIMINI

Progetto: Realizzazione di un piano di mobilità nell'Area industriale di San Giovanni in M. - Cattolica

Questionario sugli spostamenti casa - lavoro del personale occupato nell'area produttiva

 PROVINCIA DI RIMINI	Questionario	  
	Sugli spostamenti casa - lavoro del personale occupato nell'area di San Giovanni-Cattolica	

Gentile Signora, Gentile Signore,

nell'ambito di un progetto europeo che coinvolge altre aree industriali, la Provincia di Rimini, in collaborazione con le Amministrazioni di San Giovanni e Cattolica, le imprese, le Associazioni economiche e sindacali, sta adoperandosi per migliorare la mobilità nell'Area industriale di San Giovanni-Cattolica, cercando, nelle forme possibili, di ridurre l'uso delle auto a favore di altri mezzi (pubblici, bici, ecc.) meno inquinanti per l'ambiente (ogni giorno, in Italia, 20 persone muoiono prematuramente per le conseguenze dell'inquinamento dell'aria, che colpisce soprattutto bambini e anziani).

La compilazione del questionario ci aiuterà a capire meglio tempi e modi per raggiungere il lavoro, e questo ci fornirà informazioni utili alla predisposizione di tutte le misure di miglioramento possibili. La Sua collaborazione è quindi molto importante.

IL QUESTIONARIO, COMPILATO, DOVRÀ ESSERE RIPORTATO IN AZIENDA E DEPOSITATO NELLE APPOSITE URNE IL GIORNO SUCCESSIVO A QUELLO DEL RITIRO, AL MASSIMO UN GIORNO DOPO.

Per informazioni/aiuto alla compilazione contattare Monica Maioli o Primo Silvestri al tel. 0541 786652.

Nota Bene: per rispondere fare una crocetta sul quadratino prescelto oppure scrive nello spazio a fianco.

Ai sensi della legge 675/96 si comunica che le informazioni acquisite attraverso il presente questionario serviranno esclusivamente per la predisposizione di progetti relativi alle modalità di trasporto del personale dell'Area, attraverso

1. Dati personali

Genere/Sesso 1.1 Uomo 1.2 Donna

1.3 Età

1.4 Comune di residenza/domicilio(da dove parte per andare al lavoro)

1.5 Di quante persone è composta la sua famiglia ? N°..... componenti.

1.6 Di cui figli/e n°..... (rispondere alle 2 domande successive se presenti figli/e in età scolare)



- 1.7 Frequentano Asilo o scuola materna n°.... Scuola elementare e media n°.....
 Scuola superiore n°..... Università n°
- 1.8 L'asilo/materna o la/e scuola/e sono nello stesso comune di residenza? Sì No
Se in altri comuni, dove?
- 1.9 Oltre a Lei, quali altri componenti della sua famiglia lavorano? (*rispondere solo se presenti altri componenti che lavorano*)
 Coniuge Figli Genitori Altri..... (*specificare*)
- 1.10 Quante auto avete in famiglia?, chi le usa quotidianamente.....

2. Catena degli spostamenti

- 2.1 Distanza in km dalla casa al lavoro:
 fino a 2 km da 2 a 5 km da 6 a 10 km da 10 a 50 km oltre 50 km
- 2.2 Quando esce di casa: va direttamente al lavoro fa altri giri...tipo
↓
 lasciare i figli all'asilo/scuola
 fare acquisti
 altro(*specificare*)
- 2.3 Durante la pausa pranzo: torna a casa non torna a casa
↓ ↓
Perché è comodo mangia in mensa
 deve preparare per i familiari mangia in azienda
 deve prendere i figli a scuola mangia al bar/ristorante
 altro..... altro.....
- 2.4 La sera, normalmente, dopo il lavoro:
 va direttamente a casa prima di rientrare si ferma in altri luoghi per
↓
 fare acquisti
 ritirare i figli da qualche parte
 altro..... (*specificare*)

3. Orari di lavoro

- 3.1 A che ora parte, la mattina, da casa?
- 3.2 A che ora arriva al lavoro?



3.3 Il suo lavoro prevede turni settimanali/mensili (con conseguente cambiamento di orario)

No

Orario di lavoro:

Mattino dalle alle

Pomeriggio/sera dallealle

Orario continuato dalle alle

.....

L M M G V S

(segnare, con una X, per quale giorno della settimana questo orario è valido)

Si

1° Turno

2° Turno

dalle alle dalle alle

dalle alle dalle alle

dalle alle dalle alle

L M M G V S L M M G V S

4. Mezzi di trasporto

4.1 A lavorare va in:

- Auto
- Mezzi pubblici (bus)
- Bici
- Moto
- Mezzo aziendale
- Treno
- A piedi

SE VA IN AUTO (altrimenti saltare)

Va in auto in qualità di: conducente passeggero

Utilizza l'auto perché: (fino a 2 risposte segnando, per importanza, con 1 la prima e con 2 la seconda)

più confortevole

più veloce

più economica

non ci sono mezzi alternativi

consente più libertà negli spostamenti

altro.....(specificare)

Sul luogo di lavoro è facile parcheggiare

Si No

Ha mai provato a mettersi d'accordo con qualche collega che fa lo stesso percorso per condividere l'auto?

- Sì, abitualmente
 - Spesso
 - Qualche volta
 - No perché
- (specificare)

SE VA IN BUS (altrimenti saltare)

Prende il bus n°..... o della linea

Lo prende perché è comodo

non è comodo, ma non ci sono alternative (fino a 2 risposte, segnando con 1 la prima e con 2 la seconda)



Problemi

orari scomodi

poche corse

fermate lontane dal luogo di lavoro



Progetto: Realizzazione di un piano di mobilità nell'Area industriale di San Giovanni in M. - Cattolica

- devo prendere più bus
- poca puntualità
- altro.....

.....

SE VA IN BICI (*altrimenti saltare*) (fino a 2 risposte, segnando con 1 la prima e con 2 la seconda)

- Ha scelto la bici perché è il mezzo:
- più rapido
 - più salutare
 - meno costoso
 - altro(*specificare*)

Il percorso casa-lavoro è sicuro ? Si No

Cosa propone per migliorare l'utilizzo della bici (piste ciclabili, stanza per cambio, rastrelliere coperte nel cortile dell'azienda, ..., altro)

.....

(PER TUTTI)

D'estate utilizza gli stessi mezzi che d'inverno ? Si No

Se la risposta è NO, cosa utilizza con maggiore frequenza d'estate ?

5. Alternative possibili

Immagina di non poter utilizzare, per qualche motivo, il suo abituale mezzo di trasporto per andare al lavoro: quale alternativa adotterebbe? (fino a 2 risposte segnando, per priorità, con 1 la più probabile e con 2 la seconda scelta)

<input type="checkbox"/>	Cerco di prendere un mezzo pubblico
<input type="checkbox"/>	Prendo un giorno di ferie
<input type="checkbox"/>	Mi faccio accompagnare da qualche collega
<input type="checkbox"/>	Prendo un mezzo privato (auto)
<input type="checkbox"/>	Mi faccio accompagnare da un familiare/amico
<input type="checkbox"/>	Vengo a piedi
<input type="checkbox"/>	Vengo in bicicletta
<input type="checkbox"/>	Prendo un taxi
<input type="checkbox"/>	Altro (specificare -)

Sarebbe disposto/a a recarsi al lavoro in **BUS** ? (*se già non lo utilizza*)

(fino a 2 risposte segnando, per priorità, con 1 la prima scelta e con 2 la seconda)

<input type="checkbox"/>	Se esistesse un collegamento diretto casa-lavoro/ oppure buone coincidenze
<input type="checkbox"/>	Se passasse all'interno dell'area industriale, con fermate non troppo lontano dall'Azienda
<input type="checkbox"/>	Se gli orari (la loro frequenza) fossero compatibili con quelli di lavoro (senza dover attendere troppo)
<input type="checkbox"/>	Se ci fossero abbonamenti convenienti



PROVINCIA
DI RIMINI

Progetto: Realizzazione di un piano di mobilità nell'Area industriale di San Giovanni in M. - Cattolica

<input type="checkbox"/>	NO, ci impiegherei più tempo
<input type="checkbox"/>	NO, non sarebbe comodo
<input type="checkbox"/>	Altro (specificare)

Se **NON** la utilizza già, sarebbe disposto/a a usare la **BICI**, compresa la bici a pedalata assistita, per recarsi al lavoro ? (sono ammesse sino a 2 scelte, indicandone la priorità: 1, 2).

<input type="checkbox"/>	Sì, se ci fossero migliori e più sicure piste per le biciclette
<input type="checkbox"/>	Sì, se fossero disponibili parcheggi dedicati e sicuri all'interno dell'Azienda
<input type="checkbox"/>	Sì, ma SOLO D'ESTATE.
<input type="checkbox"/>	Sì, se non trovassi più parcheggio per l'auto vicino al posto di lavoro
<input type="checkbox"/>	Se fosse data la possibilità di cambiarsi in azienda
<input type="checkbox"/>	No, troppo lontano
<input type="checkbox"/>	No, non è comodo
<input type="checkbox"/>	Altro (specificare)

Il **TRENO** potrebbe essere una buona alternativa per andare al lavoro ? (se già non lo utilizza)

<input type="checkbox"/>	No, in nessun caso
<input type="checkbox"/>	Sì, se dalla stazione di Cattolica ci fosse un collegamento funzionale (BUS) con l'area industriale
<input type="checkbox"/>	Sì, se dalla stazione di Cattolica ci fossero delle biciclette da poter utilizzare per raggiungere il lavoro
<input type="checkbox"/>	Altro (specificare)

IL QUESTIONARIO, COMPILATO, DOVRÀ ESSERE RIPORTATO IN AZIENDA E DEPOSITATO NELLE APPOSITE URNE IL GIORNO SUCCESSIVO A QUELLO DEL RITIRO, AL MASSIMO UN GIORNO DOPO.

Grazie per la collaborazione

Template ITACA showcases CONCABUS – call transport service		
1	Title of the showcase / best practice	In the 9 cities of the Valle del Conca since 2008 is being experimented a call transport service which allows people to book few hours in advance a place in a small bus stopping at the closest prearranged stop to the caller's house. It is a kind of collective taxi with flexible timetable and non-prearranged stops as the TPL. It is used very much by old people, students and occasional users. It has achieved a great success and it may be extended to other areas with similar characteristics in the Province
2	Objective of the showcase	To increase collective mobility and to diminish the use of private cars
3	Metropolitan region / city	Province of Rimini
4	Owner/executor and participants	Cities in Valconca area and Emilia Romagna Region (which partially financed the initiative)
5	Description: - Content and process - Timetable - Finance - Results	Started in 2008, it is still running and has met a good success. It costs around 100.000 euros the first year and 60.000 the following years. Euro 57.000,00 – (art.31 della Legge Regionale 30/1998)
6	Low Carbon Contribution (quantify if possible)	75 T less CO2
7	Lessons learnt	Improvement of local transport
8	Other relevant information	---
9	Website	http://www.provincia.rimini.it/progetti/mobilita/news/2009_02_09.htm

Template ITACA showcases		
1	Title of the showcase / best practice	Piano spostamento casa-lavoro dei dipendenti provinciali. È uno strumento di sviluppo, implementazione e controllo di un insieme ottimale di misure utili per razionalizzare gli spostamenti casa-lavoro che include servizi e attività.
2	Objective of the showcase	Favorire la mobilità sostenibile
3	Metropolitan region / city	Provincia di Rimini
4	Owner/executor and participants	Comuni della costa e Regione Emilia Romagna
5	Description: - Content and process - Timetable - Finance - Results	In attuazione alle politiche di Mobility Management sono state attuate alcune misure: <ul style="list-style-type: none"> • i dipendenti provinciali possono usufruire di biciclette posizionate presso la stazione ferroviaria per favorire la mobilità treno + bici; • è stata data possibilità, ai dipendenti che dalla propria abitazione si reca al lavoro in bici di usufruire gratuitamente della riparazione e manutenzione della propria bicicletta recandosi presso meccanici convenzionati con la Provincia di Rimini. • Tramite accordo con “Tram Servizi” ai dipendenti che si recano al lavoro con il mezzo pubblico (autobus) viene scontato al 50% il costo dell’abbonamento sottoscritto mensilmente o annualmente.
6	Low Carbon Contribution (quantify if possible)	---
7	Lessons learnt	La presenza di queste iniziative contribuisce alla diversione modale di oltre quaranta dipendenti dall’utilizzo dell’auto propria
8	Other relevant information	---
9	Website	http://www.provincia.rimini.it/progetti/mobilita/index.htm

Template ITACA showcases		
1	Title of the showcase / best practice	DRAFT for ERR Car-Sharing
2	Objective of the showcase	
3	Metropolitan region / city	ERR
4	Owner/executor and participants	
5	Description: - Content and process - Timetable - Finance - Results	<p>Monitoraggio del car-sharing regionale</p> <p>La complessità delle relazioni e degli spostamenti del vivere quotidiano determina fenomeni, quali la congestione da traffico e l'inquinamento, che contrastano con l'esigenza sempre più elevata di qualità della vita personale.</p> <p>In questo contesto, per quanto in considerevole ritardo rispetto alle scelte previamente compiute nelle principali città del Nord Europa, si registra nelle nostre aree urbane un forte impegno per lo sviluppo di sistemi di mobilità che possono favorire una migliore fruizione delle città.</p> <p>L'espansione delle zone a traffico limitato, lo sviluppo della mobilità ciclo-pedonale, il car pooling e il car sharing costituiscono, in tal senso, sistemi che sostengono i cambiamenti delle abitudini degli automobilisti creando nel contempo quella cultura delle buone pratiche della mobilità atta a determinare positivi e vantaggiosi risultati in termini di miglior qualità della vita per l'intera collettività.</p> <p>In Emilia-Romagna il servizio di Car Sharing aderente ad ICS - Iniziativa Car Sharing - (in origine "Iniziativa dei Comuni per il Car Sharing") è presente a Bologna, Modena, Parma e Rimini (a Rimini il servizio è cessato nel marzo 2009), recando una dimensione di offerta pari a 75 autovetture "ecologiche", dislocate complessivamente in 51 punti di prelievo: ICS, alla quale possono aderire quegli Enti che abbiano approvato e sottoscritto la convenzione costitutiva di ICS ed il Protocollo di Intesa con il Ministero dell'Ambiente, persegue esplicitamente l'attivazione del servizio sul territorio nazionale e la sua diffusione e promozione presso gli utenti finali attraverso la partecipazione diretta degli Enti Locali, fornendo altresì alle città aderenti facilitazioni concrete per l'avvio dei servizi di Car Sharing nei rispettivi territori.</p> <p>Gli Enti che hanno aderito a ICS sono: i Comuni di</p>

	<p>Bari, Bologna, Brescia, Catania, Firenze, Genova, Livorno, Mantova, Matera, Milano, Modena, Novara, Palermo, Padova, Parma, Perugia, Pescara, Reggio Emilia, Roma, Savona, Scandicci, Sesto Fiorentino, Taranto, Torino, Trieste, Venezia, Viareggio, unitamente alle Province di Alessandria, Biella, Catania, Firenze, Milano, Rimini, Bologna, Torino e Napoli.</p> <p>Nel periodo intercorrente dalle prime applicazioni di car sharing nella Regione Emilia-Romagna (il servizio è partito nel 2003) è possibile riscontrare, in termini positivi, il soddisfacente radicamento nelle principali città ed il contestuale incremento del numero di utenti, al quale è ascrivibile un trend di crescita dell'ordine di alcuni punti percentuali annui, a fronte degli ingenti incrementi del 2004 e del 2005 rispettivamente del 41% e del 33%; l'incremento percentuale progressivo registrato dal 2003 al 2009 risulta pari all'85%, essendo gli iniziali 925 utenti aumentati sino a giungere agli attuali 1.709. Comparando il dato regionale con quello nazionale (riferentesi alle città di Firenze, Genova, Savona, Milano, Palermo, Roma, Torino, Venezia e Brescia) l'incremento annuale registrato nel più vasto ambito si rivela maggiormente cospicuo, pari al 59% nel 2004, al 64% nel 2005%, al 46% nel 2006, al 30% nel 2007, al 17% nel 2008 ed al 21% nel 2009: l'incremento percentuale progressivo registrato dal 2003 al 2009 risulta pari al 605%, essendosi gli iniziali 2.128 utenti incrementatisi sino a giungere agli attuali 14.994.</p> <p>L'attuale numero di utenti a livello regionale rappresenta pertanto l'11% di quello nazionale, mentre la flotta veicolare - al pari dei parcheggi resi disponibili - risultano pari al 13%: per quanto concerne il numero di corse effettuate a livello regionale esse ammontano a 17.124 (12% del dato nazionale, pari a 137.789 corse), mentre i chilometri percorsi risultano pari a 760.267 (12% del dato nazionale, pari a 6.147.340 chilometri) e le ore di utilizzo ammontano a 113.580 (13% del dato nazionale, pari a 838.289 ore).</p> <p>In Emilia-Romagna il servizio di Car Sharing (non aderente a ICS) è altresì significativamente presente a Reggio Emilia, con una dimensione di offerta contestualmente pari a 102 utenti e 45 autovetture (e scooter) a basse emissioni inquinanti recanti molteplici possibilità di utilizzo sia nel breve che nel medio e nel lungo periodo, dislocate complessivamente in un unico punto di prelievo: il numero di corse effettuate nel 2009 risulta pari a 1.229, i chilometri percorsi nel medesimo periodo di</p>
--	--

	<p>tempo risultano pari a 744.000 e le ore di utilizzo ammontano a 82.800. A tale modalità si affianca altresì il preminente servizio di noleggio di furgoncini elettrici (oltre 300) per il trasporto di persone e merci a servizio delle attività commerciali in area urbana.</p> <p>Tra gli elementi di maggior criticità relativi al car sharing è possibile annoverare l'ancor relativamente limitata disponibilità di mezzi e di punti di presa in carico/restituzione dell'auto condivisa: tale motivazione esplica pressoché compiutamente il limitato numero di utenti rilevato, direttamente ripercuotentesi sul problematico equilibrio economico gestionale del servizio.</p> <p>Occorre inoltre considerare che gli utenti del servizio consistono generalmente in persone orientate a sfruttare appieno la possibilità di muoversi liberamente nelle zone a traffico limitato dei centri storici e nei giorni, ormai inevitabili, di blocco del traffico o delle targhe alterne attuati per contrastare l'inquinamento atmosferico.</p> <p>Una distribuzione maggiormente capillare dei punti di prelievo delle vetture, affiancata ad una gestione informatizzata finalizzata all'eliminazione della riconsegna del veicolo nel punto di prelievo (modalità one way) e non esclusivamente limitata alle città in cui il servizio è già presente (ma bensì orientata verso l'attivazione di un centro unificato di prenotazione atto a relazionare tutte le città dotate di car sharing sull'intero territorio nazionale), costituirebbero le leve maggiormente proficue volte al conseguimento di un accresciuto utilizzo del servizio nei prossimi anni.</p> <p>Occorre altresì rimarcare le difficoltà incontrate in mancanza di un adeguato supporto statale sia dalle Regioni che dagli Enti locali relativamente al sostegno ed alla promozione/incentivazione del sistema del trasporto pubblico locale, primariamente finalizzato al mantenimento del livello di servizio oggi offerto, del quale il car sharing rappresenta un'ideale modalità complementare volta a contrastare il grave fenomeno dell'inquinamento atmosferico nelle città.</p> <p>Italian to English translation Monitoring of regional car-sharing</p> <p>The complexity of relationships and movements of everyday life results in phenomena such as traffic congestion and pollution, which contrast with the need for more and higher quality of personal life.</p> <p>In this context, as in a considerable delay compared</p>
--	--

	<p>to the choices previously made in the major cities of northern Europe, in our urban areas there is a strong commitment to developing mobility systems that can facilitate better use of the city.</p> <p>The expansion of the restricted traffic zones, the development cycle and pedestrian mobility, car-pooling and car sharing are, in this sense, systems that support the changing habits of drivers while creating a culture of good practices capable of mobility to determine positive and beneficial results in terms of improved quality of life for the whole community.</p> <p>In Emilia Romagna the service member to ICS Car Sharing - Car Sharing Initiative - (originally "Initiative of Commons for car sharing") is present in Bologna, Modena, Parma and Rimini (Rimini service was terminated in March 2009), bringing a dimension of 75 cars offer "green", located in a total of 51 sampling points: ICS, to the participation of those organizations that have approved and signed the constitutive convention of ICS and the Memorandum of Understanding with the Ministry of 'Environment, explicitly seeks to activate the service on national territory and its dissemination and promotion to end users through the direct participation of local authorities, including providing concrete facilities to member cities to start car sharing services in their territories .</p> <p>Organizations that have joined the ICS are: the cities of Bari, Bologna, Brescia, Catania, Florence, Genoa, Livorno, Mantova, Matera, Milan, Modena, Novara, Palermo, Padua, Parma, Perugia, Pescara, Reggio Emilia, Rome , Savona, Scandicci, Sesto Fiorentino, Taranto, Turin, Trieste, Venice, Viareggio, together with the provinces of Alessandria, Biella, Catania, Florence, Milan, Rimini, Bologna, Turin and Naples.</p> <p>In the period from the first car-sharing applications in the Emilia-Romagna (the service started in 2003) you can find, in positive terms, satisfactory grounding in the major cities and the simultaneous increase in the number of users, which is attributable to a growth trend of the order of several percentage points per year, compared to large increases in 2004 and 2005, respectively 41% and 33%, the percentage increase recorded progressively from 2003 to 2009 amounted to 85%, being the 925 initial users increased until reaching the current 1,709. By comparing the data with the national regional (referring to the city of</p>
--	--

	<p>Florence, Genoa, Savona, Milan, Palermo, Rome, Turin, Venice and Brescia), the annual increase recorded in the broader context reveals more substantial, amounting to 59% in 2004 , 64% in 2005% to 46% in 2006 to 30% in 2007 to 17% in 2008 and to 21% in 2009: the percentage increase recorded progressively from 2003 to 2009 amounted to 605%, having the incrementatizi 2,128 initial users until reaching the current 14,994.</p> <p>The current number of users at regional level is therefore 11% of the national one, while the vehicle fleet - like parking available - amounted to 13% with regard to the number of runs made at the regional level these amount to 17,124 (12% of the national figure, equivalent to 137,789 trips), while the mileage totaled 760,267 (12% of the national figure, amounting to 6,147,340 km) and amounted to 113,580 hours of use (13% of the data national, amounting to 838,289 hours).</p> <p>In Emilia-Romagna car sharing service (non-adherent to ICS) is also significantly present in Reggio Emilia, with a size of the same offer of 102 users and 45 cars (and scooters) to produce low emissions bearing usability is in short, medium and long term, total spread in a single sampling point: the number of runs made in 2009 totaled 1,229, miles traveled in the same period amounted to 744,000 hours of use and amount to 82,800. In this mode it also supports the leading rental service electric pickup trucks (over 300) for transporting people and goods in the service of commercial activities in urban areas.</p> <p>Among the most critical elements relating to car sharing is still possible to include the relatively limited availability of resources and points of care / returning the car shared: the reasoning expressed almost completely the limited number of users detected directly on ripercuotentesi economic equilibrium problem management service.</p> <p>You should also consider that users of the service generally consists of persons oriented to fully exploit the possibility to move freely in restricted traffic zones and in the days of old towns, now inevitable, blocking the traffic or number plate implemented for combating pollution pollution.</p> <p>A more widespread distribution of sampling points of the cars, combined with a computerized management aims to eliminate the return of the vehicle in the</p>
--	--

		<p>sampling point (one-way mode) and not exclusively limited to the cities where the service is already present (but rather oriented to the activation of a unified central booking place to report all cities with car sharing throughout the national territory), levers constitute maggiomente profitable times to achieve an increased use of the service in the coming years.</p> <p>It should also point out the difficulties encountered in the absence of adequate government support from both regions that the local authorities regarding its support and promotion / encouragement of local public transport system, primarily aimed at maintaining the level of service offered today, which the car represents an appropriate sharing complementary way to combat the serious problem of air pollution in cities.</p>
6	Low Carbon Contribution (quantify if possible)	---
7	Lessons learnt	
8	Other relevant information	---
9	Website	http://www.icscarsharing.it/main/

Consider also for energy efficiency:

<http://www.momo-cs.eu/index.php?unid=330a42f3b9687a1c2812369821a28154>

momo Car-Sharing



THE REGION OF EMILIA-ROMAGNA

HOME-TO-WORK TRAVEL PLAN FOR HOSPITAL CAMPUSES LOCATED IN DECENTRALISED AREAS WITHIN A PROVINCE

GUIDELINES

SUMMARY

1. PREFACE
2. GENERAL OBJECTIVES
3. METHODOLOGY OF PLAN
4. SPECIFIC OBJECTIVES
5. STRUCTURE OF PLAN
6. DIVISION OF PLAN INTO GENERAL AREAS

- Appendix 1 Research campaign
Appendix 2 Efficacy indicators of the interventions
Appendix 3 Action Plan
1. PREFACE

The Emilia-Romagna Region aims to provide guidelines for the drafting of a home-to-work travel plan (Piano per gli Spostamenti Casa Lavoro - PSCL) for hospital campuses located outside the capitals of the Province.

This document gives a general summary of the current situation relating to the hospital campus in Cona (Ferrara), paying specific attention to the preparation of an Action Plan within the scope of the PSCL.

2. GENERAL OBJECTIVES OF PSCL

The general objective of the PSCL is to reduce the use, or at least the individual use, of private cars; in order to improve in positive terms for the whole community, the quality of life of the region from an environmental, social and economic viewpoint.

The PSCL of the Hospital Campus must analyse the current situation of the region under consideration in terms of mobility supply and demand, with the aim of identifying and

implementing the measures and interventions needed to improve home-to-work transport connections, for the promotion of more environmentally sustainable means and modes of transport.

The preparation of the PSCL is an opportunity for dialogue among the Health Authority, workers and public transport companies. The plan is also an opportunity for the local authorities to get to know the different aspects of the health authority's activities, the area of origin of workers and users/visitors, the current services offered in the indicated area. It will also give insight into the economic and technical resources that each interested party will be able to bring into play to reduce negative environmental impact.

It is therefore a question of identifying the best strategies to manage transport demand, while favouring the environmentally friendly mobility options that can be adopted (bicycles and pedestrians, car pooling, car sharing, collective public and private transport, etc.). Consideration must also be given to the location and infrastructure.

If, as in the case of Cona, the Hospital Campus under consideration is also used for university functions, the PCSL should consider the specific issues relating to teaching staff and students, and identify appropriate solutions.

Finally, since there is a large number of users and visitors travelling to the Hospital Campus, the PSCL must ensure that the measures aimed to serve home-to-work mobility are also suitable for the mobility of users/visitors.

3. METHODOLOGY OF PLAN

CURRENT REGULATIONS

The PSCL must be drawn up according to related national legislation currently in force and in particular:

- Decree of Ministry of Environment: "Sustainable mobility in urban areas" of 27 March 1998 (Ronchi Decree), which foresees that all companies or public bodies with more than 300 employees in one unique location, or more than 800 employees spread over different locations, adopt a "Home-to-Work Travel Plan for employed staff (PSCL)" and nominate a mobility manager. This regulation also extends to locations with less than 300 employees, but that are located in the 23 municipalities listed in Annex III of the Ministerial Decree "updating of technical regulations relating to concentration limits and levels of caution and alarm of air pollutants in urban areas and preparation for the measurement of some pollutants according to Ministerial Decree 15/04/94" of 25/11/94, or in municipalities in the risk zones of atmospheric pollution identified by the regions according to Article 3 of the Decree of Ministry of Environment "Criteria for the elaboration of regional plans for recovery and protection of air quality" of 20/05/91.
- Ministerial Decree "Programme incentives proposed by mobility managers", Silvestrini Decree (General Manager of *Servizio IAR*, *Servizio Inquinamento Atmosferico* and *Rischi Ambientali*), of 20/12/2000, in which the implementation of mobility management is promoted through financing municipalities and/or associated forms of municipalities, not only through interventions relating to home-to-work travel, but also through "plans for the management of mobility demand relating to industrial, commercial

and small business areas, school and health campuses or areas for temporary or permanent large-scale public events” (*art. 1 paragraph 3*). At the same time, the Silvestrini Decree extends the application of the Ronchi Decree to all Italian municipalities, without restricting it to those at atmospheric risk.

The Plan must acknowledge all information listed in the programmes and studies on the sector; this information is available from the municipal authorities or from the companies or public bodies that will be involved (public service providers, trade/professional associations and consortiums, etc.).

This information must be in line with cognitive documents and be provisionally available from the regional authorities, and at ministerial level.

4. SPECIFIC OBJECTIVES

For hospital campuses with a high concentration of road transport (private, goods, etc.), managing mobility means identifying the measures and interventions needed to improve home-to-work transport connections in the area of influence of the campus.

As mentioned above, the PSCL is also an opportunity for dialogue among the Health Authority, workers and public transport companies. The plan is also an opportunity for the local authorities to get to know the different aspects of the health authority’s activities, the area of origin of workers and users/visitors, the current services offered in the indicated area. It will also give insight into the economic and technical resources that each interested party will be able to bring into play to reduce negative environmental impact.

More specifically, the plan should identify mobility management actions that essentially aim to:

- satisfy, in any case, the requirements for mobility of persons (and goods) in order to respect environmental sustainability and therefore reduce its impact from a social, environmental and economic viewpoint;
- improve accessibility to the area in question from the area of influence through greater development of sustainable transport systems such as collective transport (private and public), bicycle and pedestrian mobility and combined transport (intermodal);
- influence not only the behaviour of individuals, but also the behaviour of the Health Authority (and potentially the University) towards environmentally sustainable policies (improvement of fleet of vehicles, etc.);
- improve integration between modes of transport and facilitate links between existing transport networks, also through the development of specific information and communication systems;
- increase economic efficacy of each individual mode of transport;

The main strategic objectives are to:

promote and make known the meaning of the actions of the mobility management;
include employees in the realisation of a such an innovative project;
reduce the individual use of private cars;
make collective transport both an alternative and competitive option;
promote cycling and walking, taking into consideration distances to be covered;

reduce levels of pollution;
introduce additional (shuttle bus) and innovative (car pooling, car sharing) services for mobility and improve the system of organised transport, also, where possible, by managing the demand in a different way (timetable plan, flexible hours, etc.).

5. STRUCTURE OF PLAN

The drawing up and organisation of the Plan must be done in such a way to allow its application through coordination and consultation with the Health Authority (and potentially with the University, if present), public and private transport companies (taxi consortiums, road and rail public transport operators, private consortiums operating with the municipalities, etc.), local authorities, trade union representatives (hospital staff, teaching staff, researchers, etc.), representatives of protected person (individuals with disabilities, patients with chronic illnesses, dialysis patients, etc.), various committees (public transport users, pensioners, medicine students, other university interns, specialist student doctors, etc.) and voluntary organisations, in order to have the best feedback from all involved parties.

It is also fundamental that the mobility manager of the Hospital Authority works in close collaboration with the mobility manager of the local authority area (municipal, provincial, regional).

More specifically, the plan must develop the following:

perform a cognitive and analytical phase of the context in which it operates (identification of the area of influence of the Hospital Campus, quantifying the demand for mobility into categories (employees, users, visitors, students, medical teaching staff, protected persons, industries and any other employees, etc.), and characterisation of the transport proposal);
develop a design platform to share with the users, in which the following interventions are proposed by considering an analysis of the costs/benefits, in close collaboration with the mobility manager of the municipality area;
launch a discussion phase with the different individuals interested (mobility manager, public and private transport agencies, employees, trade unions, etc.);
develop the final design phase in light of collected observations or integrations;
prepare a programme for the implementation of interventions which identifies instruments and procedures for the subsequent adoption of the proposals of the plan (timescales, economic resources, communication instruments, management methods);
formulate a programme to monitor and update the PSCL that indicates the systems and procedures needed to control the effects of the interventions put into force, analysing the necessary economic resources.

In order to make the coordination of the individual instruments possible in the cognitive phase, the information must be gathered according to similar research systems, which need to be applied to the health authority (questionnaire for Health Authority, and possibly University), and to workers (questionnaire for employees). Ample freedom will be given when choosing the type of research (*self-completion paper questionnaires, telephone interviews with direct input of answers, etc.*), provided that homogeneity criteria are respected. Finally, the questionnaire must be distributed in such a way to ensure everyone is given a copy.

The last three points (discussion, implementation, monitoring and updating), developed at a programming and implementing level, make up the so-called PSCL Action Plan.

6. DIVISION OF PLAN INTO GENERAL AREAS

The PSCL must develop the arguments listed below:

Cognitive frame

General report and graphic representations relating to:

- Analysis of mobility demand of employees:

- design and mode of execution of the research campaign (questionnaire for Health Authority/University and employees/teaching staff/administrative staff/students) (see Appendix 1);
- construction of synthetic indicators;
- analysis of sample that has answered the questionnaire(s);
- graphic display of origins and destinations, identification of area of influence;
- analysis of modes of transport used by employees/students and those with driving licences or their own modes of transport;
- working hours of employees/students;
- average distances covered, etc.

- Detailed analysis of internal context:

geographic localisation of Hospital Campus, quantification of number of employees and employment category; characterisation of health authority transport (environmentally friendly or not), characterisation of Health Authority/University in terms of organisation of the service, service transport, transport systems or existing benefits, willingness to forms of benefits, supply of internal services relating to communication (PC, internal computer systems), trade union representation, graphic display of access points, pedestrian connections, protected routes, parking areas and quantification of distances from access points, location of bus stops, existence of services to assist users with limited mobility to pedestrian connections (availability of wheelchairs in car parks with or without staff to assist) quantification of parking proposal distinguished by internal (employees) and external (users and visitors) and by transport type (car, bicycle or motorcycle) parking system (paid, reserved, free)

- Detailed analysis of external context:

graphic display of public transport routes serving the area, stops and traffic interchange parking, graphic display of bike lanes, graphic display showing location of bike sharing, taxis, train stations, etc. graphic display of main road connections, both current and future.

- Critical issues

Lack of connections for traffic interchange (rail-road, road-road)
Lack of safe and manned parking areas for bicycles and parking for car-local public transport/rail interchange

Limited accessibility
Insufficient public transport or difficult to access
Poor accessibility for protected persons

Design frame

General report relating to:

Identification of interventions needed to improve the accessibility of the area

reduction of use of private car, (when possible, use linked to service transport, availability of a low-impact fleet, reducing additional needs by increasing services for employees within the workplace: nurseries, post offices, canteen, etc.),
increased collective car use (car pooling).

necessary requirements: regular working hours, shared route, no intermediary charges.

Who it is aimed at: university students (interns) and administrative staff. If there were an information campaign in the ward, visitors could contact patients' relatives (for example long-stay patients) to organise transport amongst themselves.

internal (employees) and external (visitors and users) parking regulations, (planning of availability to discourage use of private cars, paid parking or reserved parking for those who really need it)

incentives to use local public transport, (making it appealing for employees in terms of service and quick connections, promoting park and ride, bike and ride and a collective taxi service to points where most routes meet, etc.).

One or two weeks' free travel on special shuttle buses could be an incentive to get to know local public transport better. Or there could be promotional days of the service with fun activities (competitions to see if the bus, bicycle or car is quicker, etc.) or cost comparisons between public transport and the private car (programme that calculates differences on transport provider's website or through an agreement with ACI)

Interventions. Depending on the size of the area, either a city or suburban transport service is needed.

Possible solutions for *city public transport*: new routes to the hospital, leaving every 20 minutes, city bus stops and in locations close to other transport connections and especially in important locations for the user (city centre, close to most other routes, interchange parking facilities, train station, University, medical centres of surgeries, etc. Running of a shuttle bus for specific users and with direct routes or a city route (with stops), and more frequent services at peak times.

The bus stops must be near the hospital entrance, the various modes of transport must be fitted with systems for differently abled users (mechanical platforms for disabled users, acoustic signals for those visually impaired, low-floor vehicles for the elderly or users with limited mobility).

Possible solutions for *suburban public transport*: moving diverging routes or those near the hospital area, reducing investments and having a minor impact on the existing service. Reduction of routes or less frequent services, replacing them with a telephone taxibus service, unification of different terminuses by bringing together various origins to one destination from which there is one direct route to the hospital. Additional routes to the hospital at peak times.

Development of telephone services (taxibus)

Who it is aimed at: all users from all interested municipalities (employees, teaching staff, specialist student doctors, users, visitors)

taxibus (telephone service for the public that can be booked for long periods or occasional journeys, originating from an existing or future service in the area, concerning provincial

areas not served by local public transport)

Who it is aimed at: users, visitors, hospital staff, residents from other municipalities.

Collective taxi service: the service makes it possible to go to the hospital, leaving from specific meeting points and to make use of reduced fares depending on the number of occupants. The fares are displayed clearly yet it is not binding for the taxi to only run when full.

Who it is aimed at: if the fares are particularly economical, this could also be suitable for employees who arrange to travel together or for the likes of specialist student doctors or university lecturers. If the service is more costly, but of quality, it is directed at users and visitors who need to go to the hospital for medical appointments or to give assistance to family members and, therefore, they will only need to travel occasionally.

incentives to use bicycles or electric bicycles for distances greater than 5 km, (this depends on a relatively central location of the structure and the presence of a safe infrastructural network and safe and convenient parking facilities). It also depends on weather conditions and is proposed to be used during good weather (from March to September) and on protected bike lanes if the road system does not guarantee high safety standards.

Who it is aimed at: this depends on distances to travel and ability of individuals. It could be appropriate for students, specialist student doctors, etc.

Organisation of collective services (Health Authority and University shuttle bus service, possible agreements can also be made with other local companies or businesses to share the costs), van pooler (company van available for more employees). Vehicles can be donated by foundations or trade/professional associations. There could be transport dedicated to differently abled persons (patients with chronic illnesses, dialysis patients, etc.). There could be provision for a service that to be booked in advance or similar to a shuttle bus with an established route.

Who it is aimed at: employees, interns, specialist student doctors, differently abled persons, etc.

Identifications of interventions needed to improve mobility management of employees/users/students/visitors

flexibility and/or modified working hours for employees who perform administrative duties. It is very difficult for hospital staff to manage flexible hours due to shifts.

possibility to carry out university lectures via videoconference to avoid internal travel when the university and work locations are distant.

there could be greater flexibility in visiting hours for visitors to avoid overlapping visiting hours, shift changes, end of internships, etc. use of company transport with low environmental impact (methane, LPG, electric) for service transport.

Identification of more appropriate instruments of communication inside the structure

internal meetings,

updated information campaigns through the portal(s) of interested Municipality/ies, the Health Authority, the University, committees of all possible users (citizens, local public transport users, protected persons, voluntary associations, etc.)

advertising campaigns,

advertising in company magazines,

flyers and billboard posters,

fun-recreational events to inform users and get them involved.

Identification of incentive strategies

identification of individuals to get involved

incentives, benefits and promotions for alternative transport (discounted passes, reserved parking areas, prizes and bonuses for purchasing and maintaining environmentally sustainable transport, etc)
disincentive policies (paid parking).

EXAMPLES OF APPLICATIONS IN ITALY AND ABROAD

Check the objectives are achieved by defining efficacy indicators (see Appendix 2)

Action Plan

Discussions with interested parties

Focus groups

Discussion with those interested in using the transport (represented by: employees, students, differently abled persons' committee, representatives for patients' rights, trade unions, health authority mobility managers, local authority representatives, public transport users, pensioners' committee, university teaching staff representatives, specialist student doctors, etc.)

Targeted meetings

Discussions with transport service providers and resource suppliers (administrators, companies, etc.)

Implementation and management of interventions

Programme of technical and economic feasibility

Planning of implementation times (temporary programme of interventions)

Planning of implementation methods

Definition of operational plans

Evaluation of maximum costs for the incentives and management and monitoring of the interventions

Programme of available financing applications and possible forms of future co-financing

Implementation of strategies for the communication and management of the interventions

Identification of individuals to get involved

Identification of strategies and instrumentation

Implementation of methods of communication and advertising of planned actions (creation of interactive computer portals to choose the most suitable system of transports, flyers, leaflets, announcements, etc.)

Coordination with mobility providers for the practical management of the interventions

Monitoring

Programme for annual monitoring

Setting up a database

Identification of individuals responsible for data collection

Identification of efficacy indicators

Focus group for annual checks

Carrying out monitoring

Collection of periodic reports edited by responsible individuals
Data processing
Calculation/Updating of efficacy indicators
Drafting of summary

APPENDIX 1

RESEARCH CAMPAIGN

Special attention must be given to data collection, by means of a questionnaire, which should be organised and approved by the mobility manager of the municipality area. The Plan must follow the indications listed below.

Research campaign specifications

Research programme

- Definition of times and methods of distribution and collection of questionnaire.
- Formulation of informative and awareness campaign in the Health Authority, also through representatives from trade unions, to inform employees on the policies of the mobility management and on the relevance of the questionnaires that will be distributed.
- Distribution and collection of questionnaires (possibly with staff pay slips or via email for university students).

Structure of questionnaires

The questionnaires serve to find out employees' current choice of transport, and also their future willingness to use alternative transport instead of the private car. In addition, there also needs to be a chance to collect information on the companies operating in the area.

- The questionnaire must be anonymous, easy to read and easy to interpret. It must state that the questionnaires will only be used for reasons specified and the privacy laws must be noted.

The questionnaire must have a cover letter, stating the objectives of the Health Authority and explaining benefits to employees. There must also be indications of the date and the place of collection and how to fill out the answers. It could be useful to list the names of the internal hospital staff or trade/professional representatives, who can be contacted for further information.

Research form for Health Authority

The questionnaire is aimed at the staff manager or mobility manager.
The questionnaire must have the following minimum requirements:

Section 1: General information on the employees

Number of employees with fixed working hours

Number of part time employees

Number of shift workers

Number of employees who perform telecommuting

Employee categories (employees, senior staff, nurses, technicians, etc.)

External staff providing regular services (cleaning companies, porters, specialist technicians, loaders/unloaders, internal service managers, business practices, etc.)

Number of employees divided by sex and age range

Section 2: General information on working hours

Working hours

Shift hours

Varied and non-defined working hours

Section 3: Information on proposal of hospital services

Internal parking facilities (for employees)

External parking facilities (for visitors and users) and related parking charges

Transport service for employees (if so, specify characteristics: free or not, modes of transport, routes, timetables and number of employees who use it).

Section 4: Information on instruments of communication

Internal network or computer connected to internet

Electronic mailbox

Hospital magazine

Internal email system (intranet)

Hospital website

Video conferences

Social club for employees or other meeting places

Internal union representation.

Section 5: Willingness to adopt mobility management policies

Economic benefits for the use of public transport (bus, train)

Incentives for those who cycle

Benefits for those who use car pooling (convenient parking facilities near entrance)

Disincentives for those who use private transport (merit classification for parking, through a list of conditions)

Flexible working hours

Programme of guaranteed return

Leased hospital transport for employees

Availability of annual budget for these interventions

Research form for university employees/students

The questionnaire must have the following minimum requirements:

Section 1: General information

sex

age

profession (office workers, teaching staff, specialist student doctors, students, etc.)

degree course
year of enrolment

Section 2: origin and destination of travel

origin of employees/students (province, municipality, street name, street number) (for students a temporary address is needed, especially if students do not live in hometown)
qualification

For questions in this section, it is necessary to insert an initial filter and to differentiate who does/does not have a fixed origin and destination.

Section 3: working hours

working hours (start/finish)
flexible times (indicate range of working hours and frequency)
part-time work
working hours that change more than once a week without a fixed outline (teaching staff and students)

Section 4: choice of transport

transport used (one or combination of different transport)
those with driving licences or not (students)
different choice depending on summer or winter
limited route (need to accompany others or do errands)

Section 5: level of satisfaction of chosen transport and willingness to use alternative transport

reason for choice of transport
criticism and suggested alternatives
view of public transport
difficulties related to parking
free space for additional comments and suggestions

Section 6: willingness to change mode of transport

willingness to use alternative modes of transport with or without economic incentives (question directed to those who normally use private car)

APPENDIX 2

POSSIBLE SET OF EFFICACY INDICATORS OF THE INTERVENTIONS

EFFICACY INDICATORS	
Indicator	Trend
Number of employees	
Parking spaces for employees	
Parking spaces for visitors/users	
Motorcycle parking spaces for employees	
Motorcycle parking spaces for visitors/users	

Bicycle parking spaces for employees	
Bicycle parking spaces for visitors/users	
Cars used/100 employees	
Cars used as driver/100 employees	
Car used as passenger/100 employees	
Motorcycles used/100 employees	
Bicycles used/100 employees	
Car pooling users/100 employees	
Local public transport users/100 employees	
Suburban bus users/100 employees	
City bus users/100 employees	
Hospital shuttle bus users/100 employees	
Users on foot/100 employees	
Answers to QSCL/total number of employees	

TREND KEY

 positive

 negative

 neutral

APPENDIX 3

ACTION PLAN

General requirements

The possible areas of intervention will be identified from the results of the Cognitive and Design Phase, maintaining collaboration that extends to all projects on alternative means of mobility (public transport, collective private car, car pooling, bicycles, etc.).

The development of the Action Plan must be operational, so that practical and manageable solutions are found in favour of involved staff (Hospital and possibly University) and all users of the new hospital campus. The solutions will be developed by taking into consideration the existing services (city and suburban local public transport), services under definition and future services.

The Action Plan is made up of three parts (operational and contextual), which are listed below:

Discussion phase (to contextualise intervention proposals)

Implementation phase

Monitoring and updating phase

Discussion phase (to contextualise intervention proposals)

As far as regular travel of employees and users of the new hospital is concerned, there will be an analysis of the proposals that best meet the demand, together with proposals that may concern the different services listed below; each type will be suitably contextualised:

the infrastructure and services present in the region of the area of influence (on completion of the contextualisation already performed during the design phase);

possible users (employees, users/visitors, teaching staff, specialist student doctors and interns, if the university function is present);

possible providers of considered services (collective public or private road or rail transport companies, taxi companies and car hire with driver, service and voluntary centres, etc.);

possible providers of economic resources for the implementation (local authorities, local health authorities, private companies, foundations, etc.).

The phase is developed by carrying out “focus groups” and targeted meetings with the interested individuals, during which all methods of intervention identified in the design phase will be considered, including:

Collect public and private road transport (city and suburban)

Collective public rail transport

Collective use of private or company car (car pooling)

Individual/collective taxi service

Standard or electric bicycle

Telephone taxi service

Implementation plan

From discussion results with the interested subjects, the interventions will be planned in terms of:

times (time period depending on level of feasibility);

method of implementation (meetings with public service providers, formalisation of agreements, drafting and signing conventions);

definition of operational plans;

definition of communication strategies to adopt (realisation of info points also inside the hospital, flyers, leaflets, press releases, portals, etc.);

estimation of necessary economic resources (for implementation of interventions, incentives, management and monitoring);

willingness of interested parties to invest (Health Authority, public authorities, public transport providers, private individuals, etc).

In particular, the communication campaign must be developed and carried out by a specialist group capable of activating all techniques and strategies needed to inform and direct users towards new proposals of alternative mobility.

Monitoring plan

Definition of an annual monitoring programme of the interventions performed and results achieved (possible focus group to update and check actions adopted with the same interlocutors initially involved in the programming phase, updating of efficacy indications).

Set-up of databases relating to adherence to incentives supplied (discounted tickets/passes, incentives to use bicycles, discount tickets for taxis, car pooling, etc.).

Identification of individuals responsible for periodic progress reports on actions adopted (number of passes sold, passenger using company services, etc.).

A summary of the monitoring plan will be written in a brief summary set out so that it can be used as a format for regular updates, with the aim of making the results and gathered information homogenous and comparable.

ANNEX II: Innovative Technologies

The goal of this document is to summarize the showcases/good practices about innovative technologies received from the ITACA partners. The distribution of showcases/best practices is as follow:

- Use of new powertrain technologies in vehicles (electric vehicles, fuel cell vehicles and hybrid vehicles, etc.)
 - Promotion of hybrid vehicles in the public transport – Taxis (Andalucía, prepared by INTA)
 - Electric Buses in Punta Umbría – Huelva (Andalucía, prepared by Diputación de Huelva)
 - Development of a fuel cell vehicle fuelled with hydrogen produced from renewable energy -Hércules Project (Andalucía, prepared by INTA)
 - Green Cab – EV taxis (Noord-Brabant, prepared by BMF)
 - Electric car sharing –COCHELE (Andalucía, prepared by INTA)
- Use of renewable energies and low carbon eco-friendly fuels (hydrogen from R.E., mix of hydrogen and methane, electricity from R.E., biogas, etc.)
 - IDROMETANO - Hydro-Methane - Hydrogen and Methane blend for public city transport bus. Technical and demonstrative application and strategic policy measures. (Region Emilia-Romagna, prepared by RER)
 - Development of a fuel cell vehicle fuelled with hydrogen produced from renewable energy -Hércules Project (Andalucía, prepared by INTA)
 - GreenCab – EV taxis (Noord-Brabant, prepared by BMF)
 - Biogas in Swedish municipalities (Stockholm region, prepared by Lidingö)
- Intelligent Transport Systems, ICT applications
 - STIMER Project – Fare and ticketing integration systems (Region Emilia-Romagna, prepared by RER)
 - Sustainable Traffic Management – integrating separate traffic management systems (the Netherlands, prepared by BMF)

- Congestion tax– electronic road pricing in Stockholm region (Stockholm, prepared by City of Lidingö)
- Rush Hour Avoidance in Randstad Holland/Brabant (Noord-Brabant, prepared by BMF)

These cases have to be analysed by ITACA partners in order to evaluate the real application of showcases/good practices in every region.

Template ITACA showcases		
1	Title of the showcase / best practice	GreenCab
2	Objective of the showcase	To gain large scale experience with clean, electric mobility.
3	Metropolitan region / city	Launch in Utrecht, roll out of franchise enterprise in the Netherlands, Belgium and Luxemburg.
4	Owner/executor and participants	Prestige GreenCab, in close collaboration with a wide range of private and government partners (see website).
5	Description: - Content and process - Timetable - Finance - Results	<p>Apart from being a 'normal' taxi company using electric vehicles, GreenCab is a test site aimed at promoting practical application of sustainable mobility technologies. This real situation provide knowledge and insight on behavioural, technical, administrative and political effects. This reveals which innovations are promising for large-scale production. In addition, the test site aims to promote the supply of certain modes of transport, such as plug-in hybrid and battery-electric vehicles. Projects are aimed at testing, learning, proving and showing these new technologies.</p> <p>The service just started with 6 electric cabs, by the end of 2011 this will increase to 40. The company also uses vehicles on biogas.</p> <p>The project receives a governments grant from the 'test site' programme for electric and hybrid vehicles. Budget of this programme is € 10 mln. The programme is chaired by a member of the Dutch Royal Family.</p>
6	Low Carbon Contribution (quantify if possible)	FEV cabs have no CO ₂ - emissions. From now until 2013 the city of Utrecht will build 300 charging points, all 100% green electricity.
7	Lessons learnt	Project has just started.
8	Other relevant information	Also see: http://www.duurzaamopweg.nl/ (in Dutch)
9	Website	http://www.prestigegreencab.nl/home/waarom-greencab/

Template ITACA showcases		
1	Title of the showcase / best practice	Electric car sharing (COCHELE)
2	Objective of the showcase	To promote the use of electric car sharing in cities.
3	Metropolitan region / city	Andalucia / Seville
4	Owner/executor and participants	COCHELE, S.L. (Private company owned by local entrepreneurs and dutch partners)
5	Description: - Content and process - Timetable - Finance - Results	<p>COCHELE is a car-sharing service, a new model of urban mobility in which the user, being a member of the service, has at its disposal a network of vehicles, which can reserve and use as needed. COCHELE also has the peculiarity of having a fleet of 100% electric vehicles.</p> <p>Electric cars are the future of urban mobility, as have many advantages over conventional vehicles, especially from the environmental point of view. The use of electric vehicles is a trend that has sought to add COCHELE by choosing this type of car for car-sharing service. The car-sharing based on conventional vehicles exists in various cities in Spain, Europe and the U.S.. Seville will be the first Spanish city to implement it with the electric car. In this city, the service brings a new model for urban, comfortable, efficient and environmentally friendly. It complements the various mobility options already exist in the city.</p> <p>European studies also assert that the existence and widespread use of car-sharing service can replace four to ten private cars, thereby increasing urban space, reduced traffic, improved energy efficiency and reducing emissions and noise pollution, improving air quality. All this results in a more liveable city, with positive impact on the health of people and a better preservation of monuments and buildings.</p> <p>COCHELE service members can book online 24 hours a day and thus use any of the cars located in the pickup and delivery.</p> <p>The points of delivery and pickup vehicles will be strategically located in commercial areas, residential and office of the city and its metropolitan area. The service offers Think City vehicles, 100% electric and high performance (110 km / hour, 180 km of autonomy). Model is a two-seats with generous luggage compartment width, perfect for urban routes throughout the city and its metropolitan area.</p> <p>An important benefit of the service is that electric cars are allowed to access to the historical center of Seville without time restriction, and there is free</p>

		<p>parking for this kind of vehicles.</p> <p>COCHELES fees includes the fixed costs of the fleet maintenance needs: insurance, taxes, maintenance and servicing, cleaning, parking at the corresponding point, and so on. The remaining costs are derived from actual use of vehicle time and mileage. At present, the monthly fee is 19.95 Euros, the cost of the hour is 4.5 Euros, and the cost of the mileage is 0.29 Euros/Km.</p> <p>COCHELE service is targeted to people who occasionally need a vehicle for their urban trips. In fact, this particular user will benefit from considerable cost savings compared with private car ownership.</p>
6	Low Carbon Contribution (quantify if possible)	
7	Lessons learnt	<p>Electric mobility offers new market opportunities. Traffic and parking restrictions in historical cities can be used to promote the use of electric vehicles.</p> <p>Car sharing is a good way to disseminate the knowledge about electric vehicles among drivers and public in general. This knowledge will increase the widespread of this technology.</p>
8	Other relevant information	
9	Website	www.cochele.es
10	Picture	

Template showcases	
1. Title of the best practice	Electric Buses
2. Precise theme/issue tackled by the practice.	Promoting the use of non-polluting public transport.
3. Objectives of the best practice.	<ul style="list-style-type: none"> -More efficient mobility. - Reduction of traffic. - Pollution abatement. - Energy savings.
4. Location.	<ul style="list-style-type: none"> - Spain - Punta Umbría (Huelva).
5. Detailed description of the best practice.	- Origin: because of the traffic and parking problems suffered by people in summer.

	<ul style="list-style-type: none"> - Timescale: The launch takes place from 2009. - Bodies involved / implementation: Consejería de Medio Ambiente of Junta de Andalucía and the Council of Punta Umbría. - Process and detailed content of the practice Punta Umbría has two relatively separate shopping areas. On one side are the streets of downtown and on the other the new shopping center located on the outskirts. To avoid displacement of people driving between both centers and decrease the flow difference between, Two electric buses have been purchased to communicate both sites with a frequency of from 15 to 20 minutes. The cost of the trip is symbolic but it may be met by buying tickets in the member establishments. - Legal framework. It doesn't exist. - Financial framework. 37.120 €
6. Evaluation	<ul style="list-style-type: none"> - Possible demonstrated results (e.g. through indicators) This practice along with other courses of action, as creating new car parks on the outside and inventories of existing ones, They make up the Sustainable Urban Mobility Plan (PMUS) of the municipality, which after a first summer experience, the results have been very positive: <ul style="list-style-type: none"> • There is a higher turnover of vehicles • Parking have been reduced in non authorized places which restricted, in most of cases, the movement of vehicles and pedestrians. • Tourists and visitors have shown their acceptance for the use of urban transport line which has seen an influx since then. • Police complaints have decreased. - Possible success factors <ul style="list-style-type: none"> • More efficient mobility. • Reduction of pollution by minimizing the vehicles in service. • Elimination of the difficulty for parking. - Difficulties encountered <ul style="list-style-type: none"> • Lack of environmental and economic awareness. • Attachment to the comfort of being independent.
7. Lessons learnt from the best practice	<ul style="list-style-type: none"> - Assess the economic savings that impact on household welfare. - Concern for the environment when

	<p>contamination is minimized.</p> <ul style="list-style-type: none"> - Knowledge of the performance that new technologies can have. - Enjoy the results of a good sustainable urban mobility plan.
8. Contact information	- Local development area of council of Punta Umbría.
9. Other possible interesting information	<p>- Various documents (reports, presentations, etc.)</p> 
10. Best practice transferred	<p>http://www.conama9.org/conama9/download/files/CTs/987984760_CLozano.pdf National Environmental Congress CONAMA9 (5/12/08) -Presentation of Sustainable Mobility Plan of Punta Umbría .</p>

Template ITACA showcases		
1	Title of the showcase / best practice	Promotion of hybrid vehicles in the public transport - Taxis
2	Objective of the showcase	To promote and support the use of hybrid vehicles in Andalucía, in particular in the public transport sector (Taxis)
3	Metropolitan region / city	Andalucía
4	Owner/executor and participants	Andalusian Regional Government, through the Agencia Andaluza de la Energía
5	Description: - Content and process - Timetable - Finance - Results	The Regional Government, through the Agencia Andaluza de la Energía, has funded the acquisition of 1,694 vehicles with hybrid technology since 2008 in the framework of different programmes to promote a sustainable energy development . The total budget of these grants has achieved 4.8 million Euros, with an impact in the economic activity of sector higher than 35

		<p>million Euros.</p> <p>Particular users can buy a hybrid car using a simple procedure which requires no formalities with the administrative offices. People only need to visit one of the dealers participating in the program, where they can find the available hybrid models in the market. The dealer, through an electronic procedure, will submit on behalf of the final user the funding request to Grant Program to Energy Development "A +" of the Agencia Andaluza de la Energía.</p> <p>The user will receive the equivalent discount on his invoice directly and no other step with the Administration is needed. This programme is open to particular users and companies located in Andalucía. Government contribution is usually around a 15% of the total cost of the vehicle.</p> <p>One of the main target of this programme is the taxi sector. In this context, the grant, and the fuel saving associated to hybrid technology in comparison with conventional taxis, has helped to more than 335 taxi drivers, until December 2010, to choose hybrid vehicles, increasing the trust of Andalusian taxi drivers in this technology, with an overall grant of nearly one million Euros.</p>
6	Low Carbon Contribution (quantify if possible)	<p>The average fuel consumption of hybrid vehicles is below five liters per 100 kilometers. For a taxi driver, running 80,000 kilometers per year mostly in urban areas, that is a fuel savings of 1,808 liters per year and prevents the emission to the atmosphere of more than 4.16 tonnes of CO₂ annually.</p>
7	Lessons learnt	<p>Total grants to hybrid vehicle acquisition are distributed in Andalucía as follow: Seville (577 vehicles), Málaga (276 vehicles), Cadiz (246 vehicles), Granada (232 vehicles), Córdoba (138 vehicles), Almeria (87 vehicles), Huelva (80 vehicles) and Jaén (58 vehicles).</p> <p>Regarding grants to acquisition of hybrid taxis, the distribution is as follow: Seville (174 taxis), Granada (59 taxis), Cordoba (43 taxis), Málaga (22 taxis), Jaén (13 taxis), Cadiz (11 taxis), Almería (7 taxis) and Huelva (6 taxis).</p> <p>In Seville for example, the success of the programme has been important because in three years the number of hybrid taxis has achieved the 8 % of the taxis in the city.</p> <p>Other lessons/suggestions:</p> <ul style="list-style-type: none"> - It should be advisable to promote also information campaigns about hybrid technology among potential users, like taxi drivers: benefits, advantages, potential disadvantages, technical differences in comparison with conventional technologies, etc. Some taxi drivers, mainly oldest, are reluctant to new technologies, due in part to the lack of information about it. - These measures should be complemented with other at local level, like the reduction of local taxes, low prices parking, etc. - To prepare a procedure among taxi driver association, taxi companies and administration to offer the possibility to the

		<p>client to choose a low carbon emissions / hybrid vehicle when a taxi is requested.</p> <ul style="list-style-type: none"> - In some cases, it is preferable to convince and support that to force. For example, the city of New York tried to force to taxi drivers to use hybrid vehicles in the new taxis without the general support of taxi drivers. Recently, this attempt to force the city's cab owners to switch from gas guzzlers to hybrid vehicles was rejected by a federal appeals court.
8	Other relevant information	
9	Website	http://www.agenciaandaluzadelaenergia.es/agenciadelaenergia/nav/com/contenido.jsp?pag=/contenidos/incentivos/incentivos_09&id=2
10	Pictures	

Template ITACA showcases		
1	Title of the showcase / best practice	Development of a fuel cell vehicle fuelled with hydrogen produced from renewable energy (Hércules Project)
2	Objective of the showcase	"Hercules" Project, has been structured around a dual purpose: to demonstrate the technical and economic feasibility of producing hydrogen from renewable solar energy; and validate the use of hydrogen in fuel cells in the automotive sector. A Spanish consortium of companies and R&D groups has being formed to achieve these goals
3	Metropolitan region / city	Andalucia/ Seville
4	Owner/executor and participants	<p>A Spanish consortium of companies and R&D groups has being formed to achieve these goals:</p> <ul style="list-style-type: none"> • Hynergreen Technologies, S.A. (Coordinator) • Greenpower Technologies, S.L. • Carbueros Metálicos, S.A. • Abengoa Solar NT, S.A. • Asociación de Investigación y Cooperación Industrial de Andalucía (AICIA) • Instituto Nacional de Técnica Aeroespacial (INTA) • Agencia Andaluza de la Energía
5	Description: - Content and process - Timetable - Finance - Results	<p>"Hercules" Project started in January 2006 and finished officially in 2010. It has been structured around a dual purpose: to demonstrate the technical and economic feasibility of hydrogen production from renewable solar energy; and validate the use of hydrogen in fuel cells in the automotive sector. To achieve these goals the cooperation of various companies and research groups is needed, specialists in each of the technology areas that are addressed in the project; so that, a Spanish consortium of private companies, a public research body, a researchers association and a public agency has been formed.</p> <p>As part of this consortium, the overall "Hercules" Project has been divided into three sub-projects:</p> <ul style="list-style-type: none"> • "Las Columnas", whose goal is the development and construction of the renewable hydrogen, from solar photovoltaic energy, production and refuelling plant. • "El León", to integrate new technologies in the automotive sector, improving energy efficiency and providing environmental benefits. • "El Olimpo", which performs the overall project coordination, evaluation, technology transfer, diffusion and dissemination of results.

		<p>Total budget of the project was around 7 million of Euros. Main deliverables of the project are:</p> <ul style="list-style-type: none"> • Private solar hydrogen refuelling station at 350 bar. • Light-duty SUV vehicle with a hybrid fuel cell/batteries.
6	Low Carbon Contribution (quantify possible) if	<p>There are no CO2 emissions in the vehicle when hydrogen is produced from solar energy.</p> <p>With an average annual mileage of 10.000 km, a direct CO2 reduction of 1.5 t per vehicle is obtained.</p>
7	Lessons learnt	<p>Hydrogen can be used in a practical and safe way as a fuel for vehicles. Hydrogen production is used also as a carrier to store electricity produced from solar energy when the power can't be injected into the grid.</p> <p>Further technical and economic improvements must be done to be competitive in terms of cost and performance with current technologies based on fossil fuels.</p>
8	Other relevant information	<p>Some partners involved in the project have decided to follow with the evaluation and optimization of the hydrogen refuelling station and the fuel cell vehicle, even without external financing, in order to use boot facilities as a platform for new developments and products.</p>
9	Website	http://www.proyectohercules.es/
10	Pictures	

Template ITACA showcases		
1	Title of the showcase / best practice	Hydro-Methane - Hydrogen and Methane blend for public city transport bus. Technical and demonstrative application and strategic policy measures. (2008-2009)
2	Objective of the showcase	The Hydro-Methane (IDROMETANO) project set out the main objective of helping to reduce the environmental impact of the public city passenger transport sector (in terms of CO ₂ and air pollutants emissions) through the use of a gaseous fuel blend up to 20% hydrogen and 80% natural gas (in short "hydro-methane")
3	Metropolitan region / city	Ravenna
4	Owner/executor and participants	Emilia-Romagna Region ATM (the Ravenna Local Public Transport Operator) ATR (the Forlì-Cesena Local Public Transport Operator) ENEA (the Italian Agency of Research)
5	Description: - Content and process - Timetable - Finance - Results	In the 2008 Emilia-Romagna Region financed ATM and ATR with a contribution of 200.000 € to each of them in order to purchase a CNG 8 meter bus (ATM) and a CNG 12 meter bus (ATR) with the aim to make some tests by using Hydromethane fuel in a private circuit. The road tests were conducted on a circuit located within the ENEA Research Center Casaccia that is similar to a typical path of bus city line. It is 3.8 km long with an altitude ranging between 132 me 152 m above sea level with alternates uphill and downhill parts.



The reduction of fuel consumption is attributable to the improved performance of the engine thanks to the positive effect of higher burn rate of hydrogen added to natural gas. The yield increase is in a range between 4% and 15% according to the variation of the fraction of hydrogen.

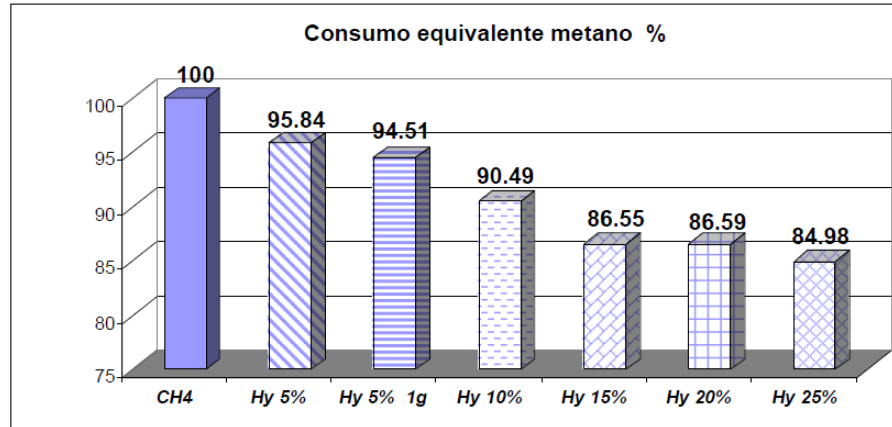

The technical interventions on the 8 m bus has been limited. There were 46% Nox emission reduces.

6 Low Carbon Contribution (quantify possible) if

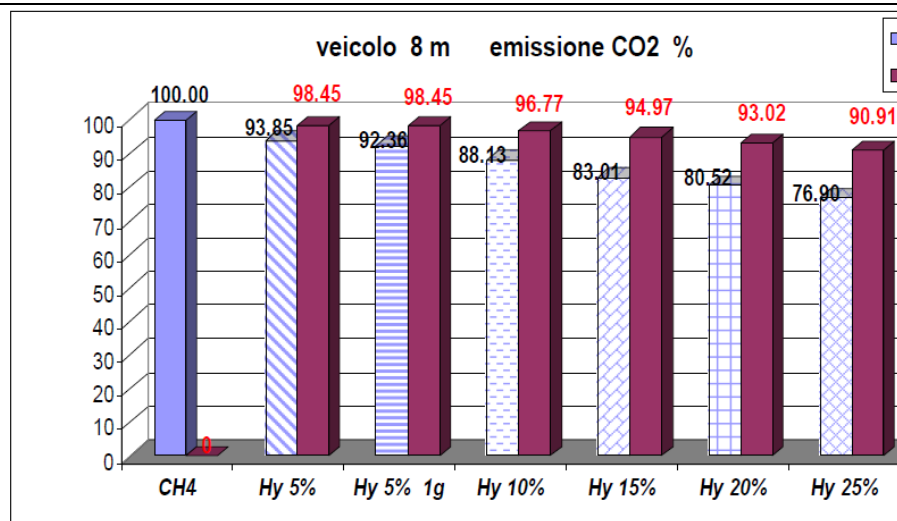

8 meter bus: CO2% emissions comparing to CNG ones

7 Lessons learnt

IDROMETANO project has showed the positive use of hydrogen mixed with methane (HCNG) but also highlighted some technological aspects for the best use of methane-hydrogen mixtures in normal commercial applications.

In urban driving the vehicle fueled by HCNG showed a positive trend of energy performance. There is a higher yield of the mixtures with increasing of hydrogen content.

The prospect of reducing CO2 emissions is one of the strengths for the use of mixtures of hydrogen and methane. There is a "leverage effect" that can amplify the reduction in CO2 emissions beyond the

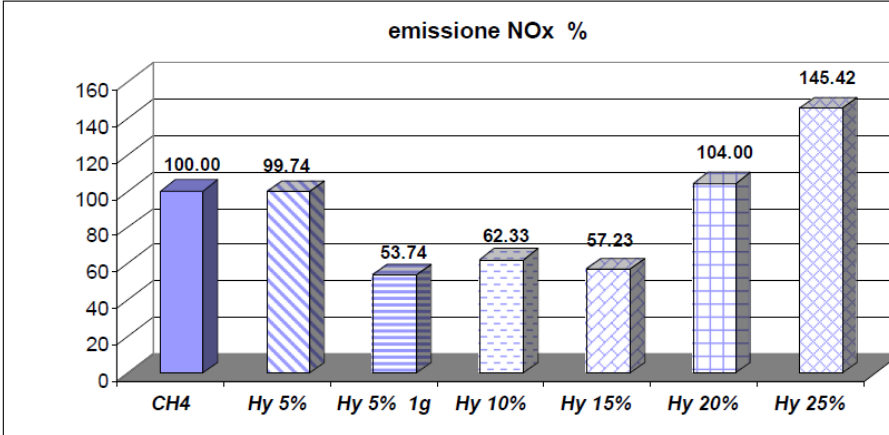
		<p>theoretical limit. CO emissions are very low. The measurements are at the limit of instrument sensitivity and no measures have shown CO below the limits imposed by the European standards and in particular for the class EEV. In the Casaccia urban cycle, NOx emissions are up to 47% less using the mixture of 5%. Similar values are also with mixtures of 10% and 15%.</p>  <table border="1"> <caption>emissione NOx %</caption> <thead> <tr> <th>Fuel Mixture</th> <th>emissione NOx %</th> </tr> </thead> <tbody> <tr> <td>CH4</td> <td>100.00</td> </tr> <tr> <td>Hy 5%</td> <td>99.74</td> </tr> <tr> <td>Hy 5% 1g</td> <td>53.74</td> </tr> <tr> <td>Hy 10%</td> <td>62.33</td> </tr> <tr> <td>Hy 15%</td> <td>57.23</td> </tr> <tr> <td>Hy 20%</td> <td>104.00</td> </tr> <tr> <td>Hy 25%</td> <td>145.42</td> </tr> </tbody> </table>	Fuel Mixture	emissione NOx %	CH4	100.00	Hy 5%	99.74	Hy 5% 1g	53.74	Hy 10%	62.33	Hy 15%	57.23	Hy 20%	104.00	Hy 25%	145.42
Fuel Mixture	emissione NOx %																	
CH4	100.00																	
Hy 5%	99.74																	
Hy 5% 1g	53.74																	
Hy 10%	62.33																	
Hy 15%	57.23																	
Hy 20%	104.00																	
Hy 25%	145.42																	
8	Other relevant information	<p>In the 2006 RER through a study carried out by ENEA had demonstrated that the mix 15% hydrogen and 85% of natural gas reduce significantly CO2 and atmospheric pollutants emissions. Furthermore, with these percentages, the overall energy balance of the system – including the hydrogen production through steam reforming process is convenient with respect to the same vehicle fuelled with natural gas.</p> <p>In the 2009 RER took part in EU LIFE+ project as coordinator called MHYBUS (2009-2011) dealing of methane and hydrogen blend with the aim to circulate with the bus in the Ravenna centre. The main specific objective of the project are:</p> <ol style="list-style-type: none"> 1. To implement the initial steps – in term of studies, technical activities, costs, time expenses for the administrative procedures – necessary to lead to a first prototype of hydro-methane bus, which will serve as leverage to start a virtuous circle towards a widespread use of hydro-methane by regional public transport utilities. 2. To provide a solid base for the implementation of air quality and climate change policy measures at Emilia-Romagna regional level. 3. To increase the Emilia-Romagna citizens' awareness in relation to climate change and air quality topics by exploiting the demonstrative potential of the vehicles prototype fuelled by hydro-methane in view of circulating in urban areas. 																
9	Website	http://mhybus.ning.com/																



Section	Indication of content
1 Title	Biogas in Swedish municipalities
2 Precise theme	How (Swedish) municipalities with indirect impact can have an effect on the regional biogas demand and supply
3 Objectives	To increase the use of biogas in metropolitan areas
4 Location	Sweden Stockholm (City of Lidingö)
5 Detailed description of the best practice	<p>Biogas materializes from waste or wastewater. When the sludge in wastewater is decaying, it emits gas that can be used to produce biogas. Likewise on our waste plants, when organic material is broken down without access to oxygen biogas is generated.</p> <p>Both the regional wastewater companies and the regional recycling and waste management companies are owned by the municipalities in the (Stockholm) region. Though each municipality manages the entrepreneur that should collect the waste in the municipality.</p> <p>This means that the municipalities can act for an increase in biogas use both with supply and demand management.</p> <p>The demand for biogas is growing and several of Stockholm's buses, taxis and private cars are run on biogas. A biogas bus has low emissions and is quieter than a diesel bus. Emissions of nitrogen oxides and particulate matter are significantly lower than for a diesel bus. Biogas adds no additional carbon to the atmosphere but is part of the natural cycle. Stockholm Public Transport (SL) is Sweden's leading provider of public transport services. On a normal weekday more than 700 000 Stockholmers use their service.</p> <p>One of SLs goals is to provide a 100% fossil free public transport not later than 2025. Today, all track vehicles run on green energy and the number of renewable fuelled buses increases steadily. SL has used biogas fuelled buses in the inner city services since 2003.</p> <p>The city of Lidingö has ensured that SL buses on Lidingö will run on biogas by different measures. As one of the owners of the waste water company, and with the sewage plant situated on the island, Lidingö has facilitated the delivering of the gas to the SL depots. As a landowner Lidingö has also been offering SL a place for a depot on the island.</p> <p>An example of demand management is public procurement. The city of Lidingö purchased, by public procurement, the garbage collection in 2008/2009 (start 2010) with a demand for biogas trucks.</p> <p>There is a lack of gas stations in the region. An example of the close relation between the municipalities demand and supply management is the gas station built (2009) at a waste plant, south of Stockholm, Hagby. The station was a result of the demands of the many municipalities for</p>

	garbage collection with biogas trucks. Later this station was also opened to civilians.
6 Evaluation	- Possible demonstrated results (e.g. through indicators) - Possible success factors - Difficulties encountered
7 Lessons learnt	
8 Contact information	http://www.sorab.se/pdf/Sorab_UK.pdf http://www.stockholmvatten.se/en/Purified-wastewater-to-protect-the-environment/Waste-products-recycled-into-new-resources/ http://sl.se/sv/Om-SL/Miljo/Biogas/
9 Other information	
10. Picture (Biogas station in Hagby, waste plant)	 A photograph showing a red car at a biogas refueling station. A person in a dark jacket and blue pants is standing next to the car, holding a blue and yellow biogas nozzle connected to the car's fuel inlet. The station is a modern, metallic structure with a digital display. In the background, other people are visible, and a sign on the station reads 'SORAB' and 'samarbeta med AGAS'. The scene is outdoors during the day.

Section	Indication of content
1 Title of the best practice	Congestion tax
2 Precise theme/issue tackled by the practice	In Sweden we use the system with congestion tax in Stockholm.
3 Objectives of the best practice	To reduce congestion, emissions and to fund new roads in the region.
4 Location	Sweden Stockholm city
5 Detailed description of the best practice	<p>The congestion tax was implemented on a permanent basis on August 1, 2007, after a seven-month trial period between January 3, 2006 and July 31, 2006, and a referendum. The tax is ultimately regulated by national law.</p> <p>Congestion tax is charged for Swedish-registered vehicles that are driven into and out of central Stockholm, Mondays to Fridays between 06.30 and 18.29. Some vehicles are exempt from congestion tax.</p> <p>Vehicles are automatically registered at 'control points' during the periods when congestion tax is charged, with automatic number plate recognition (photographs). Each passage into or out of central Stockholm costs SEK 10 (approx. 1 euro), 15 or 20, depending on the time of day. The maximum amount per day and vehicle is SEK 60.</p> <p>The Swedish Transport Agency will send a payment slip to the owner of the vehicle at the end of each month.</p> <p>The island Lidingö has its only access to the mainland through the congestion tax affected area, all traffic to and from Lidingö to and from the rest of the Stockholm County is exempt from the tax, provided that one passes one of the Ropsten bridge abutment (the mainland side of the bridge) control points and some other control point within 30 minutes of each other.</p> <p>The Essingeleden motorway, part of European route E4, that goes through the congestion tax affected area is also exempt, as it is the main route bypassing central Stockholm with no other viable alternatives present in the vicinity.</p> <p>In 2013 we also will use the system with congestion tax in Gothenburg.</p>
6 Evaluation	<p>A series of evaluations were made after the seven month trial period. All showed positive effects of the congestion tax. Traffic and emissions were reduced.</p> <p>The groups of people who in general pay the most congestion tax are men, people with high income, couples with children and people living in the inner city or Lidingö.</p>

	Both people in general and business representatives have changed their view on congestion tax as the practice has continued from a negative to a positive stand.
7 Lessons learnt from the best practice	People change behavior, and views (!) with time if pushing “the wallet buttons”.
8 Contact information	www.transportstyrelsen.se www.stockholm.se
9 Other possible interesting information	Links to evaluations : http://www.stockholmsforsoket.se/templates/MakStart.aspx?id=300 http://www.stockholmsforsoket.se/upload/Infomaterial%20VV/Faktablad_Eng_Allm_v2_3.pdf
10. Best practice transferred	

Template ITACA showcases		
1	Title of the showcase / best practice	Avoiding rush hour (in Dutch: spitsmijden)
2	Objective of the showcase	The core of the Spitsmijden projects is that drivers are tempted to change their travel behavior by financial rewards. In the region Noord-Brabant participants additionally are rewarded with relevant travel information.
3	Metropolitan region / city	Den Haag, Zoetermeer, Nijmegen, Eindhoven, Den Bosch
4	Owner/executor and participants	Several administrations (national, regional, local) and interest and knowledge institutions
5	Description: - Content and process - Timetable - Finance - Results	Mobilists who are common to drive downtown in rush hour were invited to participate in the project. The participants got a financial reward if they actually avoid driving in rush hour (Monday to Friday 07:30-09:30 a.m. and 04:30-6:30 p.m.) The reward could be €100 maximum in month. Besides the financial reward the participants get a hand held computer with gps, actual traffic information and some other services. The actual behavior of the participants had been monitored by in-car GPS. In recent years several experiments were successful. The actual project in Brabant (with the cities Eindhoven and Den Bosch) has been started in 2010 with 700 participants; another 12.000 potential participants are invited. The project in Brabant will come to an end in 2012. The organizing partners (national, regional and local authorities and several interest and knowledge organizations are positive about the results. Two universities are involved and evaluate the results.
6	Low Carbon Contribution (quantify if possible)	Some mobilists will drive outside rush hour, but also a substantial part chose other kinds transport. The CO2 reduction of the project had to be analysed further.
7	Lessons learnt	This policy of bringing people to the desired behavior seems to be far more easy to introduce than road pricing.
8	Other relevant information	Additional information from the website www.spitsmijdeninbrabant.nl <i>'The Spitsmijden project in the Netherlands'</i> At several places in the Netherlands last year found that tests are being investigated in any way we can tackle the traffic problem. Spitsmijden has proved a

		<p>successful formula. The core of the Spitsmijden projects is that drivers are tempted to change their travel behavior by financial rewards or as in-Brabant with relevant travel information.</p> <p><i>Spitsmijden projects in Nijmegen, Zoetermeer, Gouda, Rotterdam, Haaglanden (The Hague region)</i> Very successful was the project Smart Pricing Waalbrug in Nijmegen where 6,000 participants averaged 1,400 cycles per day avoidance realized. During large-scale road works because of this there were hardly any queues at this otherwise busy bridge. Also on the A12 motorway between Zoetermeer and Gouda, the traffic, thanks Spitsmijden, around major road works between 2008 and 2009 within boundaries. Projects currently ongoing or being prepared are: SpitsScoren Rotterdam, SLIM Awards in Arnhem-Nijmegen and Spitsmijden Haaglanden around The Hague.</p> <p><i>Spitsmijden in Brabant</i> Spitsmijden in Brabant is not a trial like any other. This test focuses on urban accessibility and deployment of advanced traffic information on a handheld computer. To test various new information developed. With Spitsmijden in Brabant examines the impact of this information on the travel behavior of participants.</p> <p><i>Great effect</i> Queues as more vehicles over a road like than the capacity of the road permits. It is often the case that a small decrease in the number of cars on the road if it can provide for the collection of files or even its disappearance! This effect is clearly visible in (school) holidays. It only takes a little movement, while the effect on congestion is very high.</p> <p><i>Lasting behavioural</i> Participants in previous projects often indicate that avoiding rush hour so happy that they never would otherwise! Because they save time and less stressful experience for example, but also because they feel they contribute to a better accessibility and quality of life in their region.</p>
9	Website	www.spitsmijden.nl www.spitsmijdeninbrabant.nl

Template ITACA showcases		
1	Title of the showcase / best practice	Sustainable Traffic Management
2	Objective of the showcase	To upgrade traffic management systems to a strategic level with the purpose to create optimal accessibility in urban areas in combination with substantial environmental progress. Example: green waves.
3	Metropolitan region / city	Best practices had to be selected yet. (Several practices available, according to the article in the annex)
4	Owner/executor and participants	Public authorities, ICT companies, ...
5	Description: - Content and process - Timetable - Finance - Results	<p>"A study recently completed for traffic solutions shows they could result in 40% reduction in accidents, up to 17% reduction in harmful emissions, reduce fuel consumption up to 12% and 14% reduction in travel times." (See annex.)</p> <p><i>This study has to be analyzed yet. If we decide to continue with this case, BMF will as soon as possible make contact with the author of the article (annex) to get a copy of the study and other relevant information. If we decide to continue with this subject, we expect that each partner will check in their country or region the state of the art on this subject.</i></p>
6	Low Carbon Contribution (quantify if possible)	Up to 12% reduction of fuel consumption.
7	Lessons learnt	Be aware of the Kazzoom-Brookes postulate, which in this case implies 'savings could provoke higher use'.
8	Other relevant information	<p>Relevant to Itaca because:</p> <ul style="list-style-type: none"> - It builds on systems many cities have already introduced and creates more positive effects on these systems - Practice shows real CO2 savings - Local authorities can make this innovation in traffic management happen

		<ul style="list-style-type: none"> - This innovation will serve several sometimes conflicting purposes and constraints on traffic and transport - Innovative industries are interested
9	Website	www.siemens.nl/traffic www.duurzamestad.nl

Template ITACA showcases		
1	Title of the showcase / best practice	STIMER project: FARE and TICKETING INTEGRATION SYSTEMS
2	Objective of the showcase	<p>This project has been carried out to realise a new fare structure and the relative ticketing system for the entire bus and rail transport services provided within the regional territory.</p> <p>This new system allows achieving the following objectives:</p> <ul style="list-style-type: none"> - to favour the highest level of integration among different transport modes and other mobility-connected services - to provide users with the highest freedom of movement - to assure easiness, transparency and flexibility of the fare structure - to provide transport operators and local authorities with a reliable instrument for the planning and development of services and for the control of its use
3	Metropolitan region / city	Regional Scale: extension to whole regional territory.
4	Owner/executor and participants	Emilia-Romagna Region, Local Authorities, Local Mobility Agencies, Regional LPT bus service operators, Integrated Transport Consortium.
5	Description: - Content and process - Timetable - Finance - Results	<p>Since 1994 the Emilia-Romagna Region works in synergy with the public transport companies to define a system that guarantees the maximum degree of integration between different transport modes. The regional council has defined principles, structure and specifics for an integrated system of travel documents named STIMER: the Emilia Romagna Region has approved the zoning system. The fare structure consists of a zone based price system: the travel zones are defined by taking into account both the specifics of the territory and the passenger movements in buses and trains. This has replaced the old flat-rate kilometric system and introduced consumption related fare system. In July 2001 the study of the zoning of the regional territory has been commissioned: the study involves all operators of the bus and rail services in the Region, aiming at to define the fare zones and the effect resulting from the introduction of a regional integrated travel document.</p> <p>To manage the acquisition of the necessary technologies in a single associated form, it has been established an Acquisition Committee adhered by all bus and rail transport companies in order to identify, for all companies in the Region, the technologies and software on the basis of the technical standards approved by the Bologna study.</p> <p>Electronic travel documents: SEASON- CARD based on contactless card with microchip embedded; special cards based on the same technology.</p> <p>The total amount of the Project is about 40 million Euros: 19 million Euros as regional contribution to the extension of the system to all urban and suburban territory (buses and railway), the remaining part of the amount as participation to the expenses of bus companies and</p>

		investments in railway stations to update their ticket validation systems.
6	Low Carbon Contribution (quantify if possible)	
7	Lessons learnt	<p>Main goals achieved and to be achieved in the short term:</p> <ul style="list-style-type: none"> ● Transparency, easiness, facilitation in LPT access and use ● Fare system more faithful to the service; more flexible and efficient option ● Customer fidelization ● Demand promotion <p>Emilia-Romagna Region aims at promoting intermodality also by facilitating the bike modal use, specifically on improving the access to railway stations and car parks.</p>
8	Other relevant information	<p>The main actions implemented are:</p> <ul style="list-style-type: none"> ● Integrate different transport modalities (accessibility, coordination timetable and services). ● Fare integration (STIMER project). ● Public Infomobility (GIM project). ● Integration with other modes of transport: bike and car sharing, parking etc. ● Regional Travel Planner <p>The final goal of Emilia-Romagna LPT fare integration policies is to create a one regional mobility payment card which allows the use of all LPT typologies and the access to all mobility services (car sharing, bike sharing, parking etc). The annual “Mi Nuovo” pass allows both the use of the regional railway service for pre-defined route (origin/destination) and of the urban LPT (train and bus) networks in each provincial head-towns in Emilia-Romagna plus Imola, Faenza and Carpi. “Mi Nuovo for students” is an annual pass for students up to 26 years of age which allows to travel for a whole year on saving money in comparison with the railway pass and the bus pass thanks to an 8% cost reduction.</p> <p>“Mi Nuovo All Train” allows regional railway service pass owners to take intercity trains and Eurostar City ones. Over 5000 contactless/magnetic appliances will be installed on buses and in railway stations</p>
9	Website	http://www.mobiliter.eu/wcm/mobiliter/pagine/tariffe.htm



mi nuovo

**MI NUOVO ANNUALE,
L'ABBONAMENTO UNICO REGIONALE
Treno+BUS PER VIAGGIARE
MEGLIO IN EMILIA-ROMAGNA**

TRENTALIA
GRUPPO FERROVIE DELLO STATO

Regione Emilia-Romagna
Assessorato mobilità e trasporti

The advertisement features a bright yellow background. On the left, a large green circle contains the text 'mi nuovo' in white, with three horizontal bars (green, orange, yellow) below it. To the right, the main text is in bold black and orange. A stylized orange and green line with a train icon at the end and a hand icon at the start runs across the middle. At the bottom, the logos for Trentaliam and the Emilia-Romagna Region's mobility and transport department are displayed.

ANNEX III: Alternative Vehicle Propulsion Technologies & ITS

State of the art of innovative technologies in the ITACA Project.

Discussion of practical aspects of leading propulsion technologies with potential to reduce carbon emissions, and Intelligent Transportation Systems.

With an eye to implementation, this Annex aims to provide usable nuts and bolts information to better understand these emerging and new technologies.

As introduced in Chapter 1, technology efforts today focus primarily on several leading technologies, each with the promise of potential to one day power a sizeable share of today's motorized transport, nearly all of which currently relies on the combustion of fossil fuels and subsequently massive concomitant carbon emissions.

These leading technology prospects include Battery-Electric Vehicles (BEVs), Hybrid Electric Vehicles (HEVs), Fuel Cell Electric Vehicles (FCEVs), and as a final category, internal combustion engines using either biogas, natural gas, or mixtures with hydrogen.

Intelligent Transportation Systems (ITS) are also addressed.

III.1 Alternative Propulsion Systems

III.1.1 Pure batteries electric vehicle (BEV)

A combustion engine uses only about a 30 % of fuel of its fuel tank while the rest is lost in gases and in heat losses. An electrical motor has an efficiency greater than 80 %. This advantage was well known since the 19th century; in 1889 Thomas Edison built the first electrical vehicle powered by nickel alkaline batteries [6].

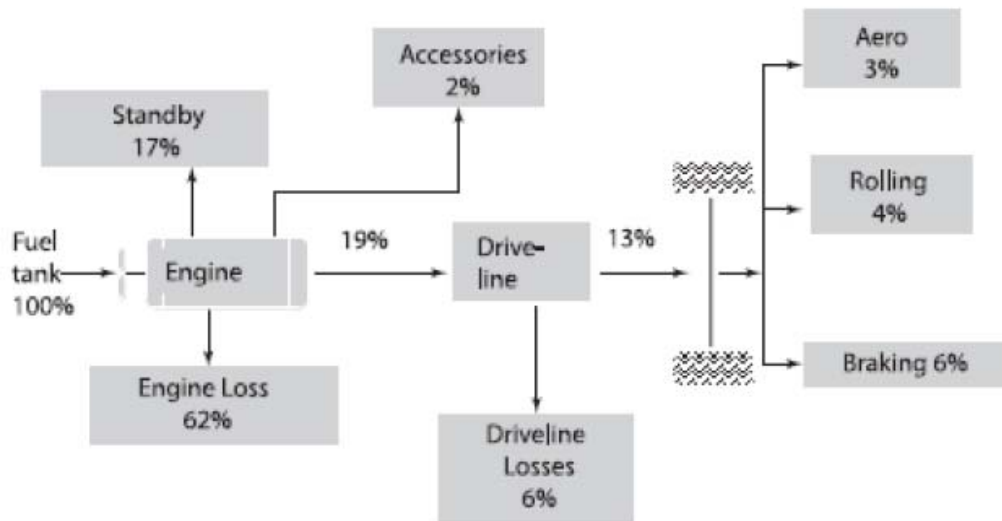

Figure III.1 Energy losses in the operation of a mid-sized passenger vehicle, using an urban driving cycle. Source: TRB

However, due to the limitations associated with the batteries and the rapid advancement in ICE vehicles, EVs have almost vanished from the scene since 1930. Nevertheless, in the early 1970s, some countries, compelled by the energy crisis, started the rekindling of interests in EVs.

In the beginning of the 21st century, California had a mandate on the use of zero emission vehicles. Today, EVs are mainly used for small vehicles and short distance applications due to the limitation of batteries.

There can be distinguished two types of vehicles which may require charging points: pure batteries electrical vehicle (BEV) and plug-in hybrid electric vehicle (PHEV) which have the capacity of charging the battery from an external power source. The BEV has only batteries as power source for powering the electric motor.

BEVs are propelled by an electric machine (EM) running on electricity stored in a battery pack.

BEVs (see Fig. 5) result when only the EM1 powertrain remains from the series-parallel hybrid architecture. Because the vehicle is powered only by batteries or other electrical energy sources, zero emission are achieved.

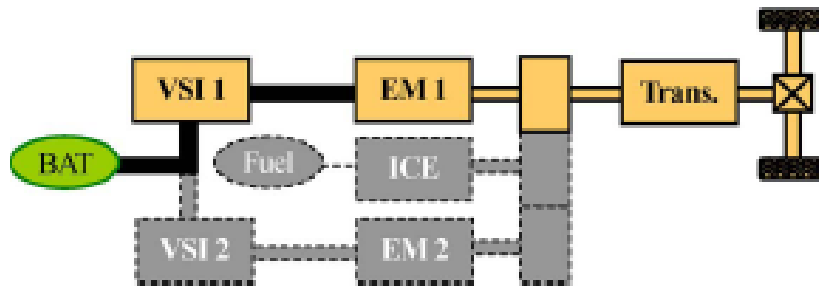

Figure III.2 BEV Configuration. Source: IEEE

In the figures referred to in this section, batteries are denoted as BAT, the fuel tank as Fuel, the Voltage Source Inverter as VSI, the Electric Machine as EM, the Internal Combustion Engine as ICE, and the Transmission as Trans. Black lines are used to designate electric couplings, and orange lines represent mechanical couplings. The transmission may be a discrete gearbox with a clutch, a continuously variable transmission (CVT), or a fixed reduction gear.

However, the high initial cost of BEVs, as well as its short driving range and long refueling time, has limited its use. Still, new BEV architectures have been proposed that use several energy sources (e.g., batteries, supercapacitors, and even reduced-power fuel cells) connected to the same dc bus [7], which should eventually reduce the refueling time, expand the driving range, and drive down the price. Table 3 shows the characteristic of BEV.

Propulsion	Electric motor drives
Energy Storage Subsystem	Batteries
	Supercapacitor
Energy and Infrastructure Source	Electrical Grid Charging Facilities
Characteristic	Zero local emission
	High energy efficiency
	Independent of fossil fuel
	Relatively short range
	High initial cost
Major Issues	Commercially available
	Battery sizing and management
	Charging infrastructure
	Cost
	Battery Lifetime

Table 3 Characteristic of BEV

Nowadays, there is under discussion the possibility of using the EVs and the PHEVs in combination with renewable energies. Specifically, it is proposed to charge the EV when there is an excess energy from renewable sources. In order to make this possible it is necessary to study the batteries of the electric vehicles, chargers, the location of the charge points and the standardization of the connectors.



Figure III.3 Connector of an electrical vehicle. Source: IEEE

III.1.2 Batteries Parameters

Batteries are key components in an EV, they store the energy used in the whole vehicle, not only in the electric motor. They are usually the component with highest cost, weight and volume. The most important parameters to characterize a battery are:

- *Battery voltage:*

The nominal voltage of a battery can be expressed by the electric equivalent circuit.

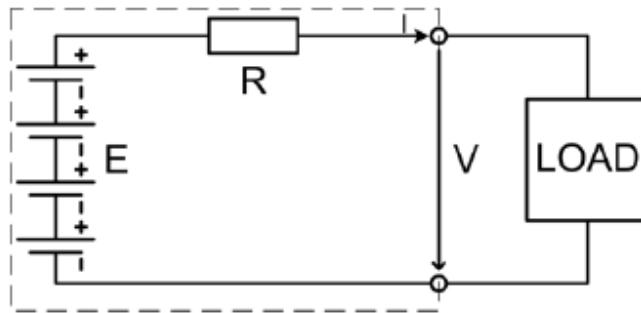

Figure III.4 Equivalent circuit of an electric battery.

The battery voltage decreases if it is delivering power and the voltage increases if the battery is charging.

- *Capacity:*

It is the amount of electrical energy which a battery can store and deliver, expressed usually in ampere hours.

The capacity of a battery depends directly in the way the energy is extracted; the quickest the energy is extracted the less capacity the battery has.

- *Energy stored*

One of the most important parameters of the batteries this parameter is the responsible of the autonomy of the vehicle.

The energy stored in a battery depends on its voltage and on its capacity. The unit for this parameter are J, but this is an inconveniently small unit, so Wh is used instead.

- *Specific energy*

Specific energy is the quantity of energy stored in the battery for every kilogram. The specific energy is typically given in Wh/kg. Typical densities are currently around 140 Wh/kg.

- *Specific power*

Specific power is the amount of power obtained for each kilogram of the battery and is measured in $W \cdot kg^{-1}$. It is important to differentiate the specific power from the specific energy: a high specific energy means that the battery can store a high energy but this does not imply that the same battery can provide the energy in a fast way which means it has a high specific power. Typical densities are currently around 730 W/kg.

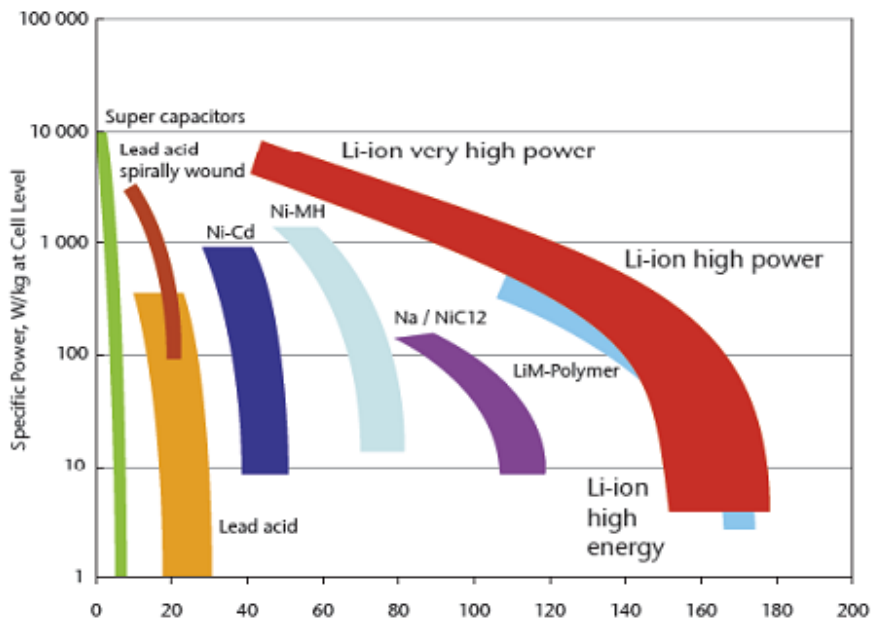

Figure III.5 Specific energy Wh/kg at cell level. Source: Johnson Control SAFT

III.1.3 Type of battery

- *Lead acid battery*

The lead acid battery is still the main type traction battery of energy system for EV today [8]. Most light EVs are powered by lead acid battery. Anyway, the ones powered by lithium battery have emerged on market.



Figure III.6 Lead acid batteries. Source: Plug-in Supply Inc

- *Ni-Cd Battery*

France is the largest consumer of Ni-Cd batteries for EVs. However, the Ni-Cd battery is fading out the market because of its bad environmental performance due to the use of Cd element.

- *Lithium Battery*

The lithium battery for energy system for EVs can be divided into four kinds according to the anode materials.



Figure III.7 LiMnO₂ Battery of MGL and the battery bus for Beijing Olympic Games.

Source: IEEE

The comparisons of different anode materials are listed in Table 4.

Anode material	LiCoO ₂	LiMnO ₂	LiFePO ₄	Li ₃ V ₂ (PO ₄) ₃
Discharge capacity(mAh/g)	130-140	100-120	~140	>170
Discharge Voltage(V)	3.6	~4.0	3.4	~4.0
Heat stability	bad	bad	best	best
Life Cycle	good	general	best	best
Safety	bad	better	better	better
price	high	low	low	lowest

Table 4 Comparisons of different anode materials

Battery Type	Energy Density [Wh/kg]	Power Density [W/kg]	Cycle Life	Operating Temp. [C]	Storage Temp. [C]	Maturity	Current Cost [\$kWh]	Future Cost [\$kWh]	Principal Manuf.
Lead-Acid	25 to 35	75 to 130	200 to 400	-18 to +70	Ambient	Production	100 to 125	75	Trojan, Hawker, Exide, Interstate
Advanced Lead Acid	35 to 42	240 to 412	500 to 800	N/A	N/A	Production	N/A	N/A	Delphi, Horizon, Electrosource
Nickel-Metal Hydride	50 to 80	150 to 250	600 to 1500	N/A	N/A	Prototype	525 to 540	115 to 300	Panasonic, Ovonic, SAFT
Nickel-Cadmium	35 to 57	50 to 200	1000 to 2000	-40 to +60	-60 to +60	Mature	300 to 600	110	SAFT
Lithium-Ion	100 to 150	300	400 to 1200	N/A	N/A	Laboratory	N/A	N/A	SONY, SAFT
Zinc-Bromide	56 to 70	100	500	N/A	N/A		300	N/A	N/A
Lithium Polymer	100 to 155	100 to 315	400 to 600	60 to 100	N/A	Laboratory	N/A	100	N/A
NaNiCl	90	100		270 to 350 (300 optimal)	N/A	Prototype	N/A	N/A	AEG Anglo
Zinc-Air	110 to 200	100	240 to 450	N/A	N/A	Prototype	300	100	Liquid Fuel Ltd
Vanadium Redox	50	110	400	N/A	N/A	N/A	300	N/A	N/A

Table 5 Comparisons of different battery type. Source: IEEE

III.1.4 Hybrid Electric vehicle (HEV)

Hybrid electric vehicles (HEVs) were developed to overcome the limitations of ICE vehicles and BEVs. An HEV combines a conventional propulsion system with an electrical energy storage system and an electric machine (EM).

In 1898, the German Dr. Ferdinand Porsche built his first car, the Lohner Electric Chaise. It was the world's first front-wheel-drive car. Porsche's second car was a hybrid, using an ICE to spin a generator that provided power to electric motors located in the wheel hubs. On battery alone, the car could travel nearly 40 miles.

By 1900, American car companies had made 1681 steam, 1575 electric and 936 gasoline cars. In a poll conducted at the first National Automobile Show in New York City, patrons favored electric as their first choice, followed closely by steam.

Hybrid and electric vehicles faded away until the 1970s with the Arab oil embargo. The price of gasoline soared, creating new interest in electric vehicles. The U.S. Department of Energy ran tests on many electric and hybrid vehicles produced by various manufacturers.

The world started down a new road in 1997 when the first modern hybrid electric car, the Toyota Prius, was sold in Japan. Two years later, the U.S. saw its first sale of a hybrid, the Honda Insight. These two vehicles, followed by the Honda Civic Hybrid, marked a radical change in the type of car being offered to the public: vehicles that bring some of the benefits of battery electric vehicles into the conventional gasoline powered cars and trucks we have been using for more than 100 years.

Along the line, over 20 models of passenger hybrids have been introduced to the auto market.

In the first few years of the 20th century, thousands of electric and hybrid cars were produced. This car, made in 1903 by the Krieger Company, used a gasoline engine to supplement a battery pack.

When HEVs are driven in the electric mode, it is possible to obtain zero emissions. HEVs demonstrate improved fuel economy, compared with conventional ICE vehicles, and have a longer driving range than BEVs.

Plug-in HEVs (P-HEVs) have an even longer range, because their battery can be recharged by plugging into an electrical grid. HEVs can help meet the challenges related to the energy crisis and pollution; however, their high purchase price is the primary obstacle to their widespread distribution.

Still, the success of the first cars on the market (e.g., Toyota Prius) indicates that HEVs constitute a real alternative to ICE vehicles. Moreover, U.S. market trends suggest that P-HEVs are becoming a very attractive and promising solution [9], [10].

Depending on the way the two powertrains are integrated, there are generally three basic HEV architectures: 1) series hybrid; 2) parallel hybrid; and 3) series-parallel hybrid, [11], [12].

- *Series-Parallel HEVs:*

A planetary gear set (Fig. 11) can be used in a series-parallel HEV [13].

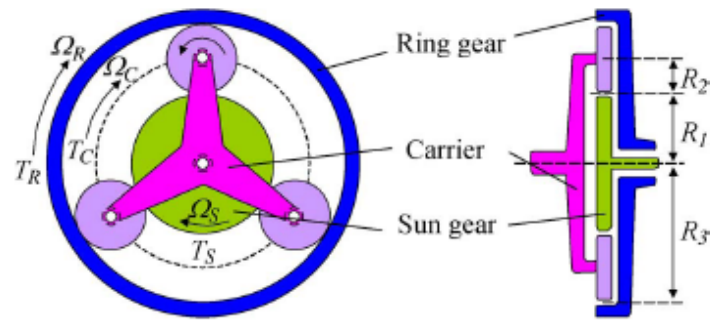

Figure III.8 Planetary gear. Source: IEEE

As shown in Fig. 12, electric machine 1 (EM1) and the transmission shaft (Trans.) are connected to the planetary ring gear set (R), whereas the ICE is connected to the carrier (C) and EM2 is connected to the sun gear (S). This architecture is depicted in such a way as to allow the other traditional architectures (i.e., series and parallel HEVs, ICE vehicles, and BEVs) to be deduced.

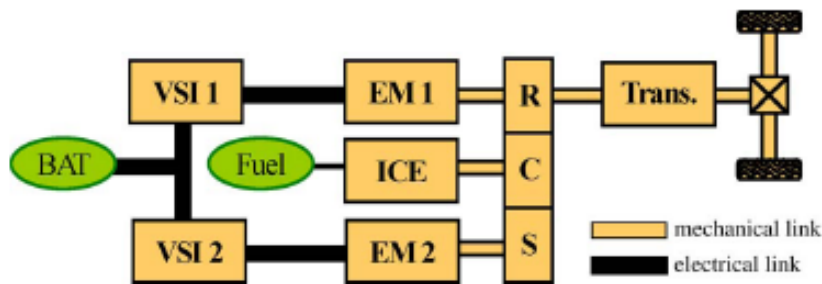

Figure III.9 Series-parallel HEV with planetary gear. Source: IEEE

Using the dc voltage bus and the planetary gear set, a series–parallel HEV can operate as either a series HEV or a parallel HEV in terms of energy flow.

The energy node can be located in the electric coupling components (e.g., the dc or ac bus) or in the mechanical coupling components (e.g., planetary gear set or others).

Although series–parallel HEVs have the features of both the series and parallel HEVs, they still require three motors and a planetary gear set, which makes the powertrain somewhat complicated and costly. In addition, controlling this architecture is quite complex.

- *Series HEVs:*

In series HEVs, all the traction power is converted from electricity, and the sum of energy from the two power sources is made in an electric node that is commonly in

a dc bus.

The ICE has no mechanical connection with the traction load, which means it never directly powers the vehicle. If the connection between the EM1 and the ICE is eliminated, a series HEV can be obtained from the series–parallel hybrid architecture. The connection between the ICE and the EM2 can be a simple gear. In this series topology (Fig. 13), the energy node between the power sources and transmission is located at the dc bus.

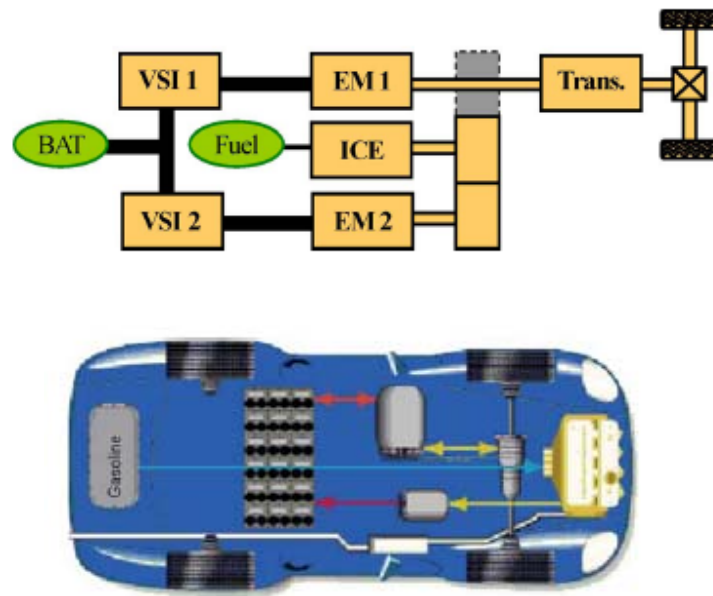

Figure III.10 Series HEV. Source IEEE

In series HEVs, the ICE mechanical output is first converted into electricity by the EM2. The converted electricity can either charge the battery or directly go to propel the wheels via EM1 and the transmission, thus bypassing the battery. Due to the decoupling of the ICE and the driving wheels, series HEVs have the definite advantage of being flexible in terms of the location of the ICE generator set. For the same reason, the ICE can operate in its very narrow optimal region, independent of the vehicle speed.

Controlling series HEVs is simple due to the existence of a single torque source (EM1) for the transmission. Because of the inherently high performance of the characteristic torque speed of the electric drive, series HEVs do not need a multigear transmission and clutch. However, such a cascade structure leads to relatively low efficiency ratings, and thus, all three motors are required. All these motors need to be sized for the maximum level of sustained power. Although, for short trips, the ICE can relatively easily be downsized, sizing the EMs and the battery is still a challenge, which makes series HEVs expensive.

- *Parallel HEVs:*

If EM2 is removed from the series–parallel hybrid architecture, a parallel HEV is obtained (Fig. 14).

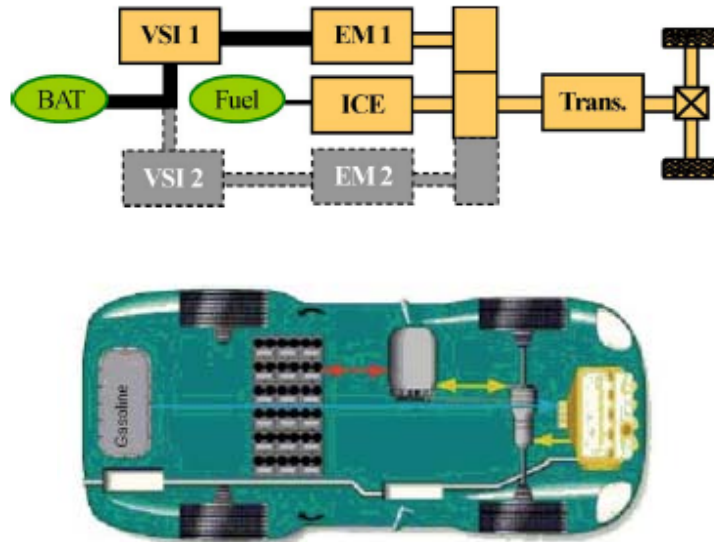

Figure III.11 Parallel HEV. Source: IEEE

In a parallel powertrain, the energy node is located at the mechanical coupling, which may be considered as one common shaft or two shafts connected by gears, a pulley-belt unit, etc.

The traction power can be supplied by ICE alone, by EM1 alone, or by both acting together. EM1 can be used to charge the battery through regeneration when braking or to store power from the ICE when its output is greater than the power required to drive the wheels. More efficient than the series HEV, this parallel HEV architecture requires only two motors: the ICE and the EM1. In addition, smaller motors can be used to obtain the same dynamic performance. However, because of the mechanical coupling between the ICE and the transmission, the ICE cannot always operate in its optimal region, and thus, clutches are often necessary.

Table 7 shows the main characteristics of HEVs:

Propulsion	Electric motor drives
	Internal combustion engines
Energy Storage Subsystem	Batteries
	Supercapacitor
	Fossil or alternative fuels
Energy and Infrastructure Source	Gasoline stations
	Electrical Grid Charging Facilities (for Plug-In Hybrid)
Characteristic	Low local emission
	High fuel economy
	Long driving range
	Dependence on fossil fuels (if biofuels are not used)
	Higher cost than ICE vehicle
	Commercially available
Major Issues	Battery sizing and management
	Control, optimization and management of multiple energy sources

Table 6 Characteristics of HEVs

The previous HEV architectures provide different levels of functionality. These levels can be classified by the power ratio between the ICE and EMs.

	Micro HEV	Mild HEV	Full HEV	Plug-in HEV
Series-parallel			x	x
Series			x	x
Parallel	x	x	x	

Table 7 Different levels of functionality

- *Micro Hybrid:*

Micro hybrid vehicles use a limited-power EM as a starter alternator, and the ICE insures the propulsion of the vehicle. The EM helps the ICE to achieve better operations at startup. Because of the fast dynamics of EMs, micro hybrid HEVs employ a stop-and-go function, which means that the ICE can be stopped when

the vehicle is at a standstill (e.g., at a traffic light).

Fuel economy improvements are estimated to be in the range of 2%–10% for urban drive cycles.

- *Mild Hybrid:*

In addition to the stop-and-go function, mild hybrid vehicles have a boost function, which means that they use the EM to boost the ICE during acceleration or braking by applying a supplementary torque. The battery can also be recharged through regenerative braking. However, the electrical machine alone cannot propel the vehicle. Fuel economy improvements are estimated to be in the range of 10%–20%.

- *Full Hybrid:*

Full hybrid vehicles have a fully electric traction system, which means that the electric motor can insure the vehicle's propulsion. When such a vehicle uses this fully electric system, it becomes a "zero-emission vehicle" (ZEV). The ZEV mode can be used, for example, in urban centers. However, the propulsion of the vehicle can also be insured by the ICE or by the ICE and the EM together. Fuel economy improvements are estimated to be in the range of 20%–50%.

- *Plug-in Hybrid:*

Plug-in hybrid electric vehicles (P-HEVs) are able to externally charge the battery by plugging into the electrical grid. In some cases, the plug-in vehicle may simply be a BEV with a limited-power ICE. In other cases, the driving range can be extended by charging the batteries from the ICE to extend the EV autonomy. This type of P-HEV is also called "range extend EV." P-HEVs are promising in terms of fuel economy. For example, the fuel economy of P-HEVs can be improved by 100% if the ICE is not used to charge the battery (e.g., in urban drive cycles).

Increasing the battery size allows ZEV operation for small trips and thus results in an important reduction in fuel consumption and greenhouse gas emissions. Many studies are being conducted about P-HEVs. Although the impact of P-HEVs on electrical grid loads needs to be examined, the initial studies have shown that P-HEVs could reduce peak demand without requiring more power plants [14].

III.1.5 Fuel Cell Electric vehicle

The first success was by Francis Bacon in 1932 (alkaline fuel cell system with porous electrodes). In the 1950s, fuel cells were used in the Apollo space program. The reason for space use was that it was the best choice: nuclear too dangerous, solar too bulky, and batteries too heavy. Fuel cells were used in Apollo, Gemini, and space shuttles.

In 1967, General Motors developed a six-passenger Electrovan, but only for use on company property due to safety reasons.

In more recent decades, a number of manufacturers including major auto makers and various government agencies have supported ongoing research into the development of fuel cell technology for use in fuel cell vehicles and other applications. Fuel cell energy has the potential to gradually replace the traditional power sources, from micro fuel cells to be used in cell phones to high-powered fuel cells for vehicle applications and stationary power generation.

From a structural viewpoint, an FCV can be considered usually as a type of hybrid vehicle, where the ICE engine is replaced by a fuel cell, because an FCV can also be equipped with batteries or supercapacitors [15]. Thus, FCVs can be considered as a type of series hybrid vehicle, in which the fuel cell acts as an electrical generator that uses hydrogen.

The onboard fuel cell produces electricity, which is either used to provide power to the machine EM1 or is stored in the battery or the supercapacitor bank for future use.

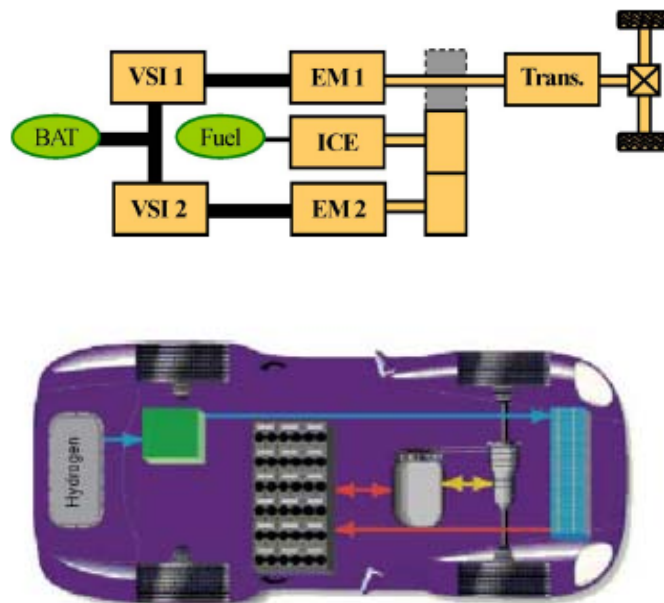

Figure III.12 Series HEV and fuel cell configuration. Source: IEEE

Table 12 shows the characteristics of FCEVs:

Propulsion	Electric motor drives
	Fuel cell to produce electricity (usually proton exchange membrane fuel cell or PEMFC)
Energy Storage Subsystem	Hydrogen storage system (high pressure or liquid)
	Batteries and/or supercapacitor needed to store energy and enhance power density
Energy and Infrastructure Source	Hydrogen
	Hydrogen production and transportation infrastructure
Characteristic	Zero low local emissions
	High energy efficiency
	Hydrogen can be produced from renewable energies (independence on fossil fuels)
	Higher cost
	Under development
Major Issues	Fuel cell cost, life cycle and reliability
	Hydrogen production and distribution infrastructure

Table 8 Characteristics of FCEVs



Figure III.13 Fuel cell electric bus. Source: HyFleet Cute

III.1.6 Internal combustion engine with biogas, natural gas and mixtures with hydrogen

Methane (CH₄) is the principle element contained in fossil-derived natural gas. Natural gas is not pure methane or a homogeneous mixture, but varies in composition by location and seasonally.

Worldwide there are about 6.7 million NGVs supported by a network of 11,500 fuelling stations.

In Europe there are around 820,400 NGVs (548,850 in the EU-27). 82.7 % are passenger cars; 6.8 % are buses; and 10.5 % are trucks. Just over 432,900 of the European NGVs are in Italy.

Today there are some 65 manufacturers worldwide that produce nearly 300 vehicle models and engines that run on natural gas. In Europe, Citroën, DaimlerChrysler, Fiat, Opel, Peugeot, Renault, and Volkswagen produce a total of 13 different category M1 factory built passenger cars running on NG/biomethane. A similar number of LD/MD commercial vehicles are offered by the same manufacturers, and by Iveco. HD engines and vehicles (buses and/or trucks) are offered by Daimler Chrysler, Ekobus, Iveco, MAN, Scania, Tedom, and Volvo. The branding of these products differs by country, and includes other well-known names such as Evobus, Heuliez, Irisbus, Neoplan, RVI, and Setra. In addition there are so called QVM (qualified vehicle modifier) options available from Ford and Volkswagen [16].

Biogas is made from organic fermented under the anaerobic condition. Therefore, many organics especially scrap organics, for example, waste and sewage in city life, organic scrap from plants, castoff of propagation and excreta of human and livestock and so on, are all the best stuffs to make Biogas.

The main components of Biogas are methane and carbon dioxide; there into, the content of methane is commonly 55%~75%, and the content of carbon dioxide is 24%~44%; besides, there are some nitrogen gas and a small quality of sulfureted hydrogen and carbon monoxide, and some other gas.

Biogas is purified to resemble natural gas (heating value, composition). It can be used as a gaseous biofuel, in which case it is called biomethane vehicle fuel. It is used exactly like natural gas, and to supply a vehicle must be compressed to 200 bar by a compression station.

III.1.6.1 Several ways of producing biogas [17]:

- In the short term, use is made of wastes or effluents of organic origin. This approach is already well developed in many European countries.
- In the medium term, it may be possible to produce biogas from energy crops.

- In the longer term, the gasification of biomass derived from lignocellulosic resources is also foreseeable.

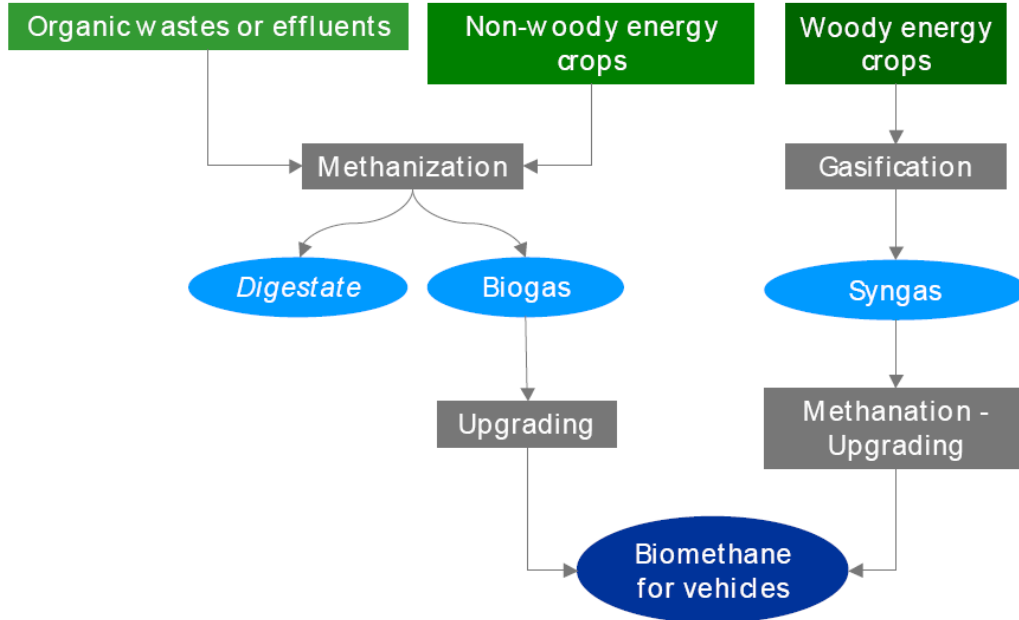

Figure III.14 Ways of producing biogas. Source: Joint study by ADEME, AFGNV, ATEE Club Biogaz, GDF SUEZ, IFP, MEEDDAT

Since the quality of biomethane is similar to that of natural gas, the incorporation of biomethane in NGV1, in any proportions, is possible with no modification either of the vehicles running on natural gas or of the associated distribution infrastructure.

III.1.6.2 Types of biogas production:

1. Storage installations for non-hazardous wastes:

Biogas is produced by the spontaneous breakdown of the fermentable fraction of buried household and similar wastes. In the conventional management mode, the production of biogas can last approximately 20 - 30 years.

2. Anaerobic digestion in a digester:

This basic process has been implemented on an industrial scale using digestion technology. After undesirable compounds have been removed, the organic matter is put into a reactor, or "digester", kept at temperatures of the order of 35°C or 50- 55°C depending on the process; the residence time can be close to twenty days. In addition to biogas, this also produces a digestate that can be

treated and composted to yield a useful organic product.

3. Biogas derived from energy crops:

In addition to the biogas potential associated with fermentable wastes, a large potential could be developed in the medium term by using farmland to grow dedicated crops that could be converted to methane, provided that this does not compete with the production of food, or with the production of other types of energy or materials from the same resource.

4. Biogas by gasification:

Biogas can also be produced from lignocellulosic biomass by a first gasification step, followed by a methanation step. This process produces Substitute Natural Gas (SNG).

Today, gasification and methanation are technologically understood, but must be adapted to biomass; the SNG production technology is still in the demonstration stage. This approach, complementary to the production of second-generation liquid biogas, uses a different biomass from that used for anaerobic digestion (more ligneous and less damp). In the long term, it would therefore make it possible to attain a biogas potential even larger than that made up of organic wastes alone.

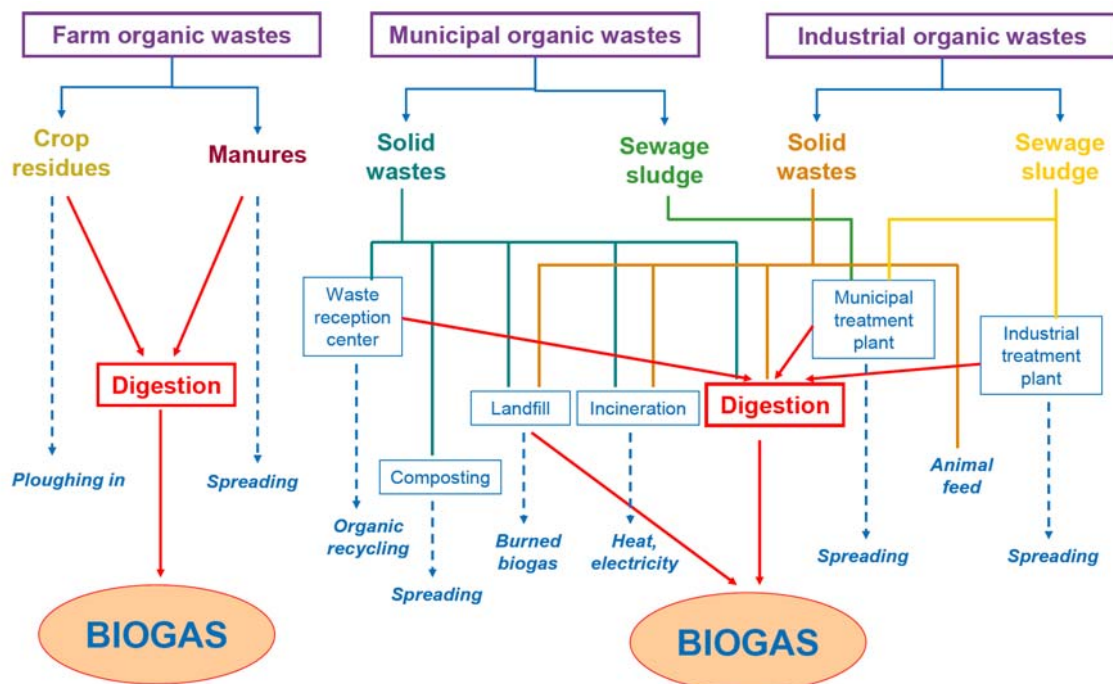

Figure III.15 Biogas vehicle fuel productions potential. Source: Joint study by ADEME, AFGNV, ATEE Club Biogaz, GDF SUEZ, IFP, MEEDDAT

The biomethane vehicle fuel production chain is divided into four main steps:

- Production of the raw biogas,
- Purification of this biogas to turn it into biomethane,
- The metering, odorization, and checking of the biomethane quality,
- Storage of the biomethane vehicle fuel, its distribution, and its compression to 200 bar.

III.1.6.3 Use of biogas in vehicles [18].

1. Light duty vehicles

Light-duty vehicles fuelled by natural gas or bio-methane will almost without exception be fitted with spark-ignition engines running at stoichiometric air (fuel ratios and will be fitted with a three way catalytic converter). In most cases these vehicles will be what is called “bi-fuel”, where they retain a petrol system alongside the gas system. This allows the vehicle to be run on either petrol or gas, as circumstances require. However, in some cases the vehicle is designed to run solely on natural gas or bio-methane and is optimised for operation on this single fuel.

2. Heavy duty vehicles

The position with heavy-duty engines is somewhat different with both lean-burn and stoichiometric spark-ignition engines being made available in the market. These engines are based on the larger diesel engines, although they use spark-ignition rather than compression ignition. These engines, not being derived from petrol-engines, are always designed to operate solely on gas as dedicated gas engines. These engines are also up to 50% quieter than their diesel equivalents.

There has also been some development in the substitution of diesel by gaseous fuels, both NG and LPG. These systems are referred to as “dual fuel” engines and use diesel as pilot ignition. The gaseous fuel is introduced into the cylinder with varying degrees of precision, ranging from fumigation of the inlet manifold to much more accurate injection into the individual ports of the engines onto the back of the inlet valves. High rates of substitution of CNG for diesel, sometimes up to 90% have been claimed. However an average of 70% is representative of fleet operation. This approach allows a vehicle to operate with the low emission benefits of natural gas whilst retaining the inherent power, efficiency and long life of compression ignition engines.

3. Fuel storage

The gas fuel is stored on the vehicle in one of two basic forms – compressed or

liquefied. Use in the compressed form, such as compressed natural gas (CNG), is the most common form of fuel storage on the vehicle. The gas is stored at high pressure, some 200 bar, in tanks. The amount of energy stored in compressed gas is significantly less than the energy stored in the same volume of liquid fuel such as diesel. Therefore the operating range of vehicles tends to be reduced.

To get round this range issue, some vehicles store the gas in liquefied form commonly known as liquefied natural gas (LNG). The gas is both cooled and compressed to become a liquid, which is again stored in high-pressure tanks on the vehicle. This method is more common in heavy vehicles as range and payload are more critical to the vehicle operation.

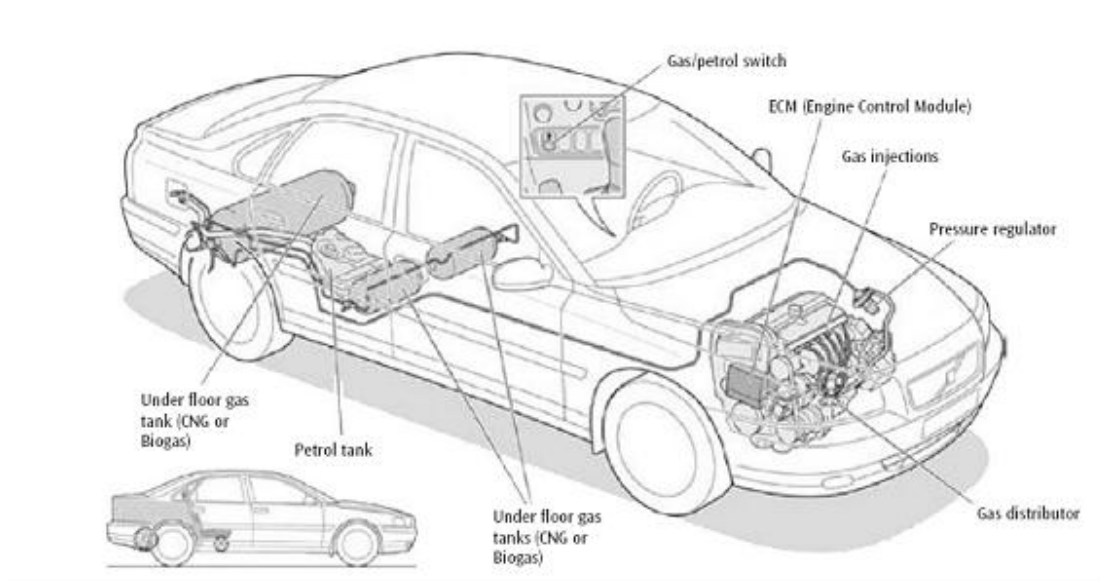

Figure III.16 Fuel storage in passenger car. Source: Volvo

III.1.6.4 Hydrogen mixtures with natural gas

Natural gas can be blended with hydrogen. Vehicles fueled with hydrogen/natural gas blends (HCNG or hydromethane) are an initial step toward the hydrogen-based transportation of the future. Hydrogen is considered one of the most promising future energy carriers and transportation fuels. Because of the lack of a hydrogen infrastructure and refueling stations, widespread introduction of vehicles powered by pure hydrogen is not likely in the near future. Blending hydrogen with methane could be one solution.

HCNG vehicles offer the potential for immediate emissions benefits, such as a reduction in nitrogen oxides (NOx) emissions. At the same time, they can pave the

way for a transition to fuel cell vehicles by building early demand for hydrogen infrastructure. In the ideal long-term scenario, hydrogen will be used mainly to power fuel cells that will convert chemical energy into electrical energy and then into mechanical energy by using electric motors. For this ideal scenario to become a reality, several hurdles have to be overcome, among them the lack of hydrogen infrastructure and appropriate onboard storage devices and the high cost of fuel cells. To begin the transition toward a hydrogen infrastructure and to address some of the issues related to hydrogen, some researchers have proposed using hydrogen to fuel internal combustion engines as a short- to mid-term solution.

Several countries, including the EU, support light- and heavy-duty hydrogen/natural gas blends projects, in particular in buses for public transport. For example, the US Department of Energy Natural Gas Vehicle Technology Forum supported a project to develop heavy-duty HCNG engines and transit buses. The HCNG (20% hydrogen, 80% CNG) engines demonstrated lower emissions, including a 50% reduction in NO_x, than similar engines fueled with CNG alone with no significant change in fuel efficiency. For a blend of 20% vol. hydrogen, a modification of the engine set points for ignition and fuel injection is required. Chassis dynamometer emission testing confirmed the substantial NO_x reduction due to HCNG when the engines were integrated into transit buses. HCNG engines operate with charge dilution (increased heat capacity of air-fuel mixture) in regimes that produce very low NO_x (lower combustion temperatures). In this blend, hydrogen is the flame enhancer that promotes combustion with a large amount of charge dilution.

The main advantages associated with use of such blends in adjusted lean burn CNG engines are:

- to reduce NO_x
- to reduce non-methane hydrocarbons
- to increase efficiency.

More details regarding the tests done, as referred to in Chapter 3:

The first phase of tests was carried out using a 12 meters long vehicle produced by Bredamenarinibus Avancity Model 240. CNG owned by ATR Forli. The vehicle is a classic 12 meters one whose laden weight reaches 17 tonnes and can carry 93 people at a maximum speed of 60 km / h. Traction is provided by a four-stroke engine powered by natural gas with a maximum power of 205 kW @ 2200 rpm and maximum torque of 1000 Nm at 1400 rpm. The engine is a Mercedes-Benz M906 LAG turbocharged with intercooler features EEV (Enhanced Environmentally friendly Vehicle, a term that indicates in a European standard emissive low emission vehicles over 3.5 tonnes in category M2 or M3). The total displacement of 6880 cm³ six-cylinder in line. The storage facility for natural gas is composed of four cylinders on the roof of the vehicle for a total capacity of 1284 l.

The second vehicle used for road tests is a short vehicle of Bredamenarini - 8 meters long - model Vivacity CNG, owned by ATM Ravenna; its laden weight reaches 9.100 kg, can carry 61 people at a maximum speed of 75 km / h.

Equipped with the same engine Mercedes of Avancity model with the same engine capacity but weakened up to 170 kW. The cylinders for natural gas are always four and are located on the roof of the medium.

The engine is lean-burn type and this can reduce NOx emissions and obtain high efficiencies. Lean burn engines work in excess air reducing fuel consumption, being able to fully exploit the fuel used in the mixture. The more difficult ignition of the mixture is overcome by an appropriate mixing between air and fuel so as to make the air-fuel mixture more homogeneous in the cylinder. In this way you avoid the nasty knock or misfire of the mixture (no burst). However, given the same output power, engine knocks or engine misfire may occur with varying excess air and therefore it is necessary to monitor carefully the operating point of the engine in order to avoid critical areas.

Alternatively, it is possible to reduce the available power to avoid the drawbacks of the engine knocks but this would reduce the engine performance.

Both vehicles are equipped with electronic control and engine management. In this unit maps setting of the engine are stored.

III.2 Intelligent transportation systems (ITS)

State-of-the-art computer technology has undergone an huge transformation in last two decades and has a great impact on every aspect of our lives with transportation being no exception. Although the rudimentary scope, goals, and value of the transportation to communities have not changed significantly, the advancement in information, communication, and sensor technologies certainly has enhanced our capacity for maneuvering ever-increasing surface transportation menaces more comprehensively and "intelligently."

According to Transport Canada (2003), ITS refers to the integrated application of information processing, communications and sensor technologies, to transportation infrastructure and operations. These systems bring together users, vehicles and infrastructure into a dynamic relationship of information exchange, resulting in better management strategies and more efficient use of available resources.

It is called Intelligent Transport Systems when combined with the individual entities that are related with the mobility such as physical infrastructure, vehicles, and controlling agencies.

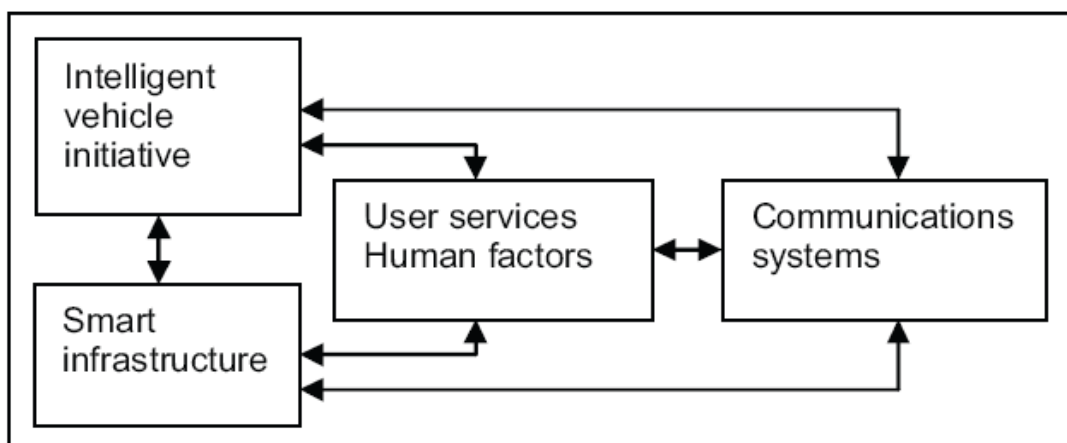

Figure III.17 ITS element. Source: Khan et al. 2005

ITS includes a myriad of products and services such as inter-modal transportation systems, intelligent traffic control systems, in-vehicle technologies, safety enhancement technologies, traveler advisory systems, and so on [19].

Intelligent transportation systems (ITS) encompass a broad range of wireless and wire line communications-based information and electronics technologies. These technologies can be integrated into the transportation system's infrastructure, and in vehicles themselves, helping to relieve congestion, improve safety and enhance productivity. ITS is made up of 16 types of technology based systems. These systems are divided into intelligent infrastructure systems and intelligent vehicle systems. These systems are [20]:

III.2.1 Intelligent infrastructure

- *Arterial Management:* Arterial management systems manage traffic along arterial roadways, employing traffic detectors, traffic signals, and various means of communicating information to travelers. These systems make use of information collected by traffic surveillance devices to smooth the flow of traffic along travel corridors. They also disseminate important information about travel conditions to travelers via technologies such as dynamic message signs (DMS) or highway advisory radio (HAR).
- *Freeway Management:* There are six major ITS functions that make up freeway management systems: Traffic surveillance systems use detectors and video equipment to support the most advanced freeway management applications. Traffic control measures on freeway entrance ramps, such as ramp meters, can use sensor data to optimize freeway travel speeds and ramp meter wait times. Lane management applications can address the effective capacity of freeways and promote the use of high-occupancy commute modes. Special event transportation management systems can help control the impact of congestion at stadiums or convention centers. In areas with frequent events, large changeable destination signs or other lane control equipment can be installed. In areas with occasional or one-time events,

portable equipment can help smooth traffic flow. Advanced communications have improved the dissemination of information to the traveling public. Motorists are now able to receive relevant information on location specific traffic conditions in a number of ways, including dynamic message signs, highway advisory radio, in-vehicle signing, or specialized information transmitted only to a specific set of vehicles.

- *Crash prevention & safety:* Crash prevention and safety systems detect unsafe conditions and provide warnings to travelers to take action to avoid crashes. These systems provide alerts for traffic approaching at dangerous curves, off ramps, restricted overpasses, highway-rail crossings, high-volume intersections, and also provide warnings of the presence of pedestrians, and bicyclists, and even animals on the roadway. Crash prevention and safety systems typically employ sensors to monitor the speed and characteristics of approaching vehicles and frequently also include environmental sensors to monitor roadway conditions and visibility. These systems may be either permanent or temporary.
- *Road weather management:* Road weather management activities include road weather information systems (RWIS), winter maintenance technologies, and coordination of operations within and between state DOTs. ITS applications assist with the monitoring and forecasting of roadway and atmospheric conditions, dissemination of weather-related information to travelers, weather-related traffic control measures such as variable speed limits, and both fixed and mobile winter maintenance activities.
- *Roadway operation & Maintenance:* ITS applications in operations and maintenance focus on integrated management of maintenance fleets, specialized service vehicles, hazardous road conditions remediation, and work zone mobility and safety. These applications monitor, analyze, and disseminate roadway and infrastructure data for operational, maintenance, and managerial uses. ITS can help secure the safety of workers and travelers in a work zone while facilitating traffic flow through and around the construction area. This is often achieved through the temporary deployment of other ITS services, such as elements of traffic management and incident management programs.
- *Transit management:* Transit ITS services include surveillance and communications, such as automated vehicle location (AVL) systems, computer-aided dispatch (CAD) systems, and remote vehicle and facility surveillance cameras, which enable transit agencies to improve the operational efficiency, safety, and security of the nation's public transportation systems.
- *Traffic Incident management:* Incident management systems can reduce the effects of incident-related congestion by decreasing the time to detect incidents, the time for responding vehicles to arrive, and the time required for traffic to return to normal conditions. Incident management systems make use of a variety of surveillance technologies, often shared with freeway and arterial management systems, as well as enhanced communications and other technologies that facilitate coordinated response to incidents.

- *Emergency management:* ITS applications in emergency management include hazardous materials management, the deployment of emergency medical services, and large and small-scale emergency response and evacuation operations.
- *Electronic payment and pricing:* Electronic payment systems employ various communication and electronic technologies to facilitate commerce between travelers and transportation agencies, typically for the purpose of paying tolls and transit fares. Pricing refers to charging motorists a fee or toll that varies with the level of demand or with the time of day.
- *Traveler information:* Traveler information applications use a variety of technologies, including Internet websites, telephone hotlines, as well as television and radio, to allow users to make more informed decisions regarding trip departures, routes, and mode of travel.
- *Information management:* ITS information management supports the archiving and retrieval of data generated by other ITS applications and enables ITS applications that use archived information. Decision support systems, predictive information, and performance monitoring are some ITS applications enabled by ITS information management. In addition, ITS information management systems can assist in transportation planning, research, and safety management activities.
- *Commercial vehicle operation:* ITS applications for commercial vehicle operations are designed to enhance communication between motor carriers and regulatory agencies. Examples include electronic registration and permitting programs, electronic exchange of inspection data between regulating agencies for better inspection targeting, electronic screening systems, and several applications to assist operators with fleet operations and security.
- *Intermodal freight:* ITS can facilitate the safe, efficient, secure, and seamless movement of freight. Applications being deployed provide for tracking of freight and carrier assets such as containers and chassis, and improve the efficiency of freight terminal processes, drayage operations, and international border crossings.

III.2.2 Intelligent vehicle systems

- *Collision avoidance:* To improve the ability of drivers to avoid accidents, vehicle-mounted collision warning systems (CWS) continue to be tested and deployed. These applications use a variety of sensors to monitor the vehicle's surroundings and alert the driver of conditions that could lead to a collision. Examples include forward collision warning, obstacle detection systems, and road departure warning systems.
- *Driver assistance:* Numerous intelligent vehicle technologies exist to assist the driver in operating the vehicle safely. Systems are available to aid with navigation, while others, such as vision enhancement and speed control systems, are intended to facilitate safe driving during adverse conditions. Other

systems assist with difficult driving tasks such as transit and commercial vehicle docking.

- *Collision notification:* In an effort to improve response times and save lives, collision notification systems have been designed to detect and report the location and severity of incidents to agencies and services responsible for coordinating appropriate emergency response actions. These systems can be activated manually, or automatically with automatic collision notification (ACN), and advanced systems may transmit information on the type of crash, number of passengers, and the likelihood of injuries.

Among intelligent vehicle systems, the main innovative technology associated directly with CO₂ emissions reduction is “Driver Assistance”.

D.G. INFRASTRUCTURAL NETWORKS,
LOGISTICS AND MOBILITY SYSTEMS
Urban Mobility and Local Public Transport Department
Viale Aldo Moro, 30
40127 Bologna (ITALY)